

[CLICK HERE TO RETURN TO FRONT PAGE](#)

Sample Cups  
and Accessories

Thin-Film  
Sample Supports

Grinding Machines  
and Accessories

Briquetting Presses  
and Accessories

Grinding/Briquetting  
Additives

Fusion Machines  
and Accessories

Standards and  
XRF/XRD Chemical Kits

## Why the Leading X-Ray Instrumentation Manufacturers Use & Recommend Chemplex...

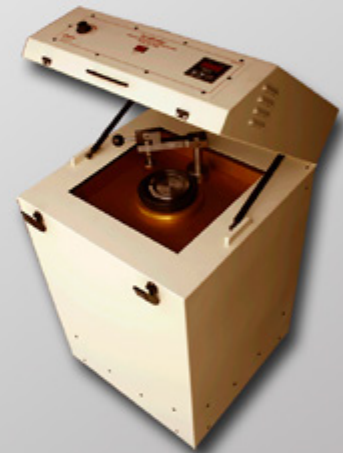

**Product Innovation**  
**Market Responsive · Technical Expertise**  
**Quality Assurance · On-Time Service**

Sample Cups  
and Accessories

Thin-Film  
Sample Supports

Grinding Machines  
and Accessories

Briquetting Presses  
and Accessories

Grinding/Briquetting  
Additives

Fusion Machines  
and Accessories

Standards and  
XRF/XRD Chemical Kits

## SpectroCertified<sup>®</sup> XRF Sample Cups



Chemplex<sup>®</sup> Industries, Inc. maintains a design engineering department together with a contemporary equipped machine shop facility. Chemplex products are manufactured “in-house” starting from the initial product conception, design, prototype, testing, and evaluation stages to finished inventoried products. In many instances, the machinery to make a product is not available necessitating the “in house” design and custom fabrication of the actual production equipment.

The design of sample cups begins with an innovative idea for a method of containing and handling liquid and powdered sample substances for x-ray analysis. Many Chemplex XRF Sample Cup designs and applications are classified as innovatively unique and have been awarded intellectual property status with the USPTO.

With a battery of injection molding machines and adjunct equipment in its manufacturing section, sample cups are: manufactured on a daily basis; subject to quality control at the production stage; packaged and labeled to avoid contamination; and inventoried under a protective environment to maintain their original quality and to assure prompt delivery.

### **SpectroCertified<sup>®</sup> XRF Sample Cup Quality Starts with a Special Formulated High Density Polyethylene**

Chemplex<sup>®</sup> XRF Sample Cups are injection molded from a proprietary high-density polyethylene specially formulated for this application. The material is characterized with:

- Compliance with RoHS Directive
- Absence of “whitening” agents that may potentially influence x-ray data
- Lubricity to facilitate the smooth and firm attachment of thin-film sample support windows
- Physical characteristics for performance and resistance to thermal and irradiation exposure
- Chemical resistance from contact with incalculable sample material substances
- Low trace element impurities

The extraordinary attention given to a special formulated plastic and maintaining consistency of its physical and chemical properties is costlier than conventionally available plastics intended for general purpose use. Chemplex<sup>®</sup> XRF Sample Cups are unmatched in material composition and properties for their intended XRF scientific applications.

Sample Cups  
and Accessories

Thin-Film  
Sample Supports

Grinding Machines  
and Accessories

Briquetting Presses  
and Accessories

Grinding/Briquetting  
Additives

Fusion Machines  
and Accessories

Standards and  
XRF/XRD Chemical Kits

## HOW TO SELECT XRF SAMPLE CUP GUIDE

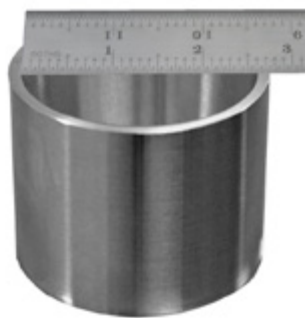

Measure Inside Diameter, **A.**

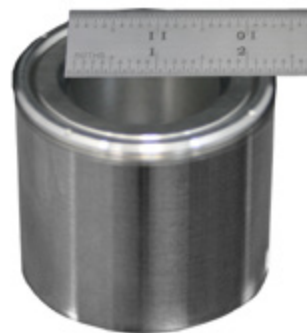

Measure Inside Diameter of the  
Aperture, **B.**



Measure Inside Height, **C.**

The traditional method of selecting a sample cup begins with taking the following three measurements of the sample cup holder or sample cup containment configuration provided with the x-ray instrumentation. A good caliper with the capability of measuring length, depth, inside and outside diameters in preferably metric units would be most helpful.

1. **THE INSIDE DIAMETER** of the sample cup holder is required in order to determine the outside sample cup diameter size. Any ridges, ledges or tapers on the inside diameter of the sample cup holder must be considered as representing the inside diameter measurement. Record the inside diameter measurement since it will be the used to help you select a sample cup.

2. **THE INSIDE DIAMETER OF THE APERTURE** represents the hole through which the primary excitation and secondary energies pass. Sample cup selection is also based on the size of the sample cup holder ledge formed by the aperture. It must be adequate in size to safely retain the sample cup and cover its edges from excitation exposure. If the aperture is larger than the sample cup it will not be retained and obviously fall through. If the aperture is smaller it might present a potential possibility of the excitation energy impinging upon the plastic sample cup that may be influential to analytical accuracy. Record this measurement for consideration in selecting a sample cup for a sample cup holder provided with your instrument.

3. **THE MAXIMUM INSIDE HEIGHT** is defined as the distance measured from the ledge forming the aperture to the top open end of the sample cup holder. The importance of this measurement is to avert overextension of the sample cup that may potentially interfere with the operational mechanics of an automatic sample advance system or prevent a lid cover from effectively closing in accordance with the x-ray equipment manufacturer's specifications.

With this information and reference to the ["Quick Reference Chart."](#) closely match a sample cup to the sample cup holder inclusive of selecting your attribute options such as "Snap-On Ring" or TrimLess® collar to affix thin-film, external or internal overflow reservoirs, vented "snap-on cap", venting method, provision for mounting Microporous Film for equalizing pressure differentials between the interior of the sample cup and sample chamber, "serrated edge snap-on rings" for trimming extraneous thin-film from the assembled sample cup, SpectroMicro® sample cups and other interesting attributes.



**XRF SAMPLE CUP QUICK REFERENCE CHART**



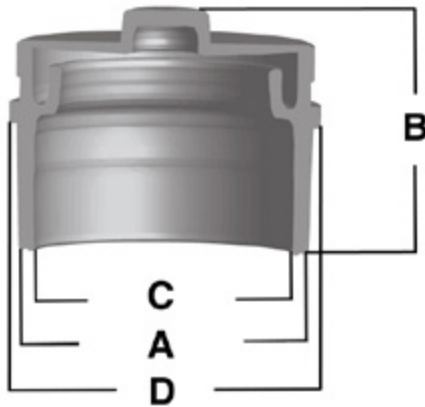

**XRF Sample Cup Dimensions, Attributes and Instrument Compatibility**



- Sample Cups and Accessories
- Thin-Film Sample Supports
- Grinding Machines and Accessories
- Briquetting Presses and Accessories
- Grinding/Briquetting Additives
- Fusion Machines and Accessories
- Standards and XRF/XRD Chemical Kits

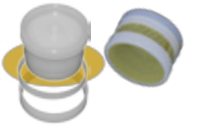
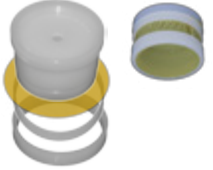

XRF Sample Cups are available in a variety of dimensions and attributes. To match a sample cup to the sample holding device (metal sample cup, rotating tray, slide platform, fixed stage, etc.) supplied with the instrumentation measure the inside diameter, height and aperture. The following generic sample cup in conjunction with the chart serves as a guide for selecting the most appropriate size. The attributes of the various types of sample cups are also indicated to better serve the application. Reference to a Series constituting specific details of the selected sample cup narrows the selection process. For more detailed information on any sample cup in a Series, simply click on the Series Number.

Series	Cat. No.	Diameter A	Height B	Aperture C	Max. Dia. D	Instrument Sample Cup Holder Compatibility	Sample Cup Attributes
<b>1000</b>	<b>1060</b>	1.23" (31.2mm)	0.93" (23.6mm)	0.96" (24.4mm)	N/A	Bruker, Oxford, Panalytical, Rigaku, Spectrace, Spectro, Thermo, Xenometrix ARL, Bruker, KeveX, Oxford, Panalytical, Rigaku, Spectrace, Thermo, Xenometrix	 <b>TrimLess® Attachment of Thin-Film Sample Supports by Use of Provided Sleeves. Venting Provision and External Overflow Reservoir.</b>
	<b>1065</b>	1.23" (31.2mm)	0.93" (23.6mm)	0.96" (24.4mm)			
	<b>1070</b>	1.52" (38.6mm)	0.90" (22.9mm)	1.19" (30.2mm)			
	<b>1075</b>	1.51" (38.4mm)	0.90" (22.9mm)	1.21" (30.7mm)			
	<b>1080</b>	1.69" (42.9mm)	0.80" (20.3mm)	1.43" (36.3mm)	1.84" (46.7 mm)	<b>SEE SpectroSulfur® Analyzer Sample Cups (Also See 1850)</b>	
	<b>1083</b>	1.69" (42.9mm)	0.73" (18.5mm)	1.43" (36.3mm)	1.84" (46.7mm)		
	<b>1085</b>	1.69" (42.9mm)	0.80" (20.3mm)	1.43" (36.3mm)	1.84" (46.7mm)		
	<b>1095</b> <i>(See 2195)</i>	1.71" (43.4mm)	1.57" (39.9mm)	1.50" (38.1mm)	1.76" (44.6mm)	Rigaku, Panalytical Venus 200	
<b>1300</b>	<b>1330</b>	1.21" (30.7mm)	0.90" (22.9mm)	0.97" (24.6mm)	N/A	Bruker, Fisons, KeveX, Oxford, Panalytical, Rigaku, Spectrace, Spectro, Thermo, Xenometrix	 <b>Re-Closable Ventable Snap-On Cap, Overflow Reservoir, Bead-to-Indent™ Snap-On Ring Geometry.</b>
	<b>1330-SE</b> Integrated thin-film trimmer						
	<b>1340</b>	1.54 (39.1mm)	0.91" (23.1mm)	1.26" (32.0mm)			

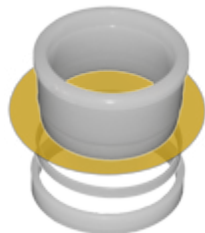
<a href="#">1400</a>	<b>1430</b>	1.22" (31.0mm)	0.88" (22.4mm)	0.97" (24.6mm)	N/A	Bruker, Fisons, Oxford, Panalytical, Rigaku, Spectrace, Spectro, Thermo, Xenometrix	 <b>Single Open-End, Double Venting Provision, Micro Sample Mounting and Powder Thin-Layered "Sandwiching" Provision, "Bead-to-Indent" Snap-On Ring Geometry. SE catalog numbers have integrated thin-film trimmer.</b>	
	<b>1430-SE</b> Integrated thin-film trimmer							
	<b>1440</b>	1.55" (39.4mm)	0.88" (22.3mm)	1.27" (32.3mm)				Bruker, Fisons, Kevex, Oxford, Panalytical, Rigaku, Spectrace, Spectro, Thermo, Xenometrix
	<b>1440L</b>	1.55" (39.4mm)	1.38" (35.1mm)	1.28" (32.5mm)	Oxford, Rigaku			
<a href="#">1500</a>	<b>1530</b>	1.22" (31.0mm)	0.91" (23.1mm)	0.94" (23.9mm)	N/A	Bruker, Fisons, Kevex, Oxford, Panalytical, Rigaku, Spectrace, Spectro, Thermo, Xenometrix	 <b>Double Open-Ended for Top Sample Loading and Affixing <a href="#">Microporous Film</a> or <a href="#">Snap-On Cap</a>; "Bead-to-indent" Snap-On Ring Geometry. SE catalog numbers have integrated thin-film trimmer.</b>	
	<b>1530-SE</b> Integrated thin-film trimmer							
	<b>1540</b>	1.55" (39.4mm)	0.91" (23.1mm)	1.22" (31.0mm)	Bruker, Fisons, Kevex, Oxford, Panalytical, Rigaku, Spectrace, Spectro, Thermo, Xenometrix			
<a href="#">1600</a>	<b>1630</b>	Vented Snap-On Caps with Interior Baffles for 1530 and 1530 SE XRF Sample Cups						
	<b>1640</b>	Vented Snap-On Caps with Interior Baffles for 1540 XRF Sample Cups						
<a href="#">1700</a>	<b>1730</b>	1.21" (30.7mm)	0.91" (23.1mm)	0.97" (24.6mm)	N/A	Bruker, Fisons, Kevex, Oxford, Panalytical, Rigaku, Spectrace, Spectro, Thermo, Xenometrix	 <b>Single Open-Ended. Snap-Post Venting and External Overflow Reservoir. SE catalog numbers have integrated thin-film trimmer.</b>	
	<b>1730-SE</b> Integrated thin-film trimmer							
	<b>1740</b>	1.54" (39.1mm)	0.93" (23.6mm)	1.26" (32.0mm)				
<a href="#">1800</a>	<b>1830</b>	1.22" (31.0mm)	0.87" (22.1mm)	0.96" (24.4mm)	N/A	Bruker, Fisons, Kevex, Niton, Oxford, Panalytical, Rigaku, Spectrace, Spectro, Thermo, Xenometrix	 <b>Single Open-Ended. External Overflow Reservoir and Venting Provision. SE catalog numbers have integrated thin-film trimmer.</b>	
	<b>1830-SE</b> Integrated thin-film trimmer							
	<b>1840</b>	1.54" (39.1mm)	0.93" (23.6mm)	1.25" (31.8mm)	Bruker, Kevex, Oxford, Panalytical, Rigaku, Spectrace, Spectro, Thermo			
<a href="#">1850</a>	<b>Low Profile 1850 Sulfur Analyzer Cups</b>	1.69" (42.9mm)	0.77" (19.6mm)	1.41" (35.8mm)	1.87" (47.5mm)	<b>SEE <a href="#">SpectroSulfur® Analyzer Sample Cups</a></b> XOS "Sindie®" And Other <b>Sulfur Analyzers (also see <a href="#">1000 Series</a>)</b>		

<b>1900</b>	<b>1930</b>	1.23" (31.2mm)	0.84" (21.3mm)	0.96" (24.4mm)	N/A	Bruker, Kevex, Oxford, Panalytical, Rigaku, Siemens, Spectrace, Spectro, Thermo, Xenometrix		
	<b>1930-SE</b> Integrated thin-film trimmer							
	<b>1940</b>	1.55" (39.4mm)	0.84" (21.3mm)	1.27" (32.3mm)				Oxford, Rigaku
<b>1940L</b>	1.55" (39.4mm)	1.39" (35.3mm)	1.27" (32.3mm)					
<b>1935-OX</b>	<b>1935-OX</b>	1.23" (31.2mm)	1.51" (38.4mm)	1.16" (29.5mm)	N/A	Oxford Lab X, MDX	Replacement for Oxford CK-100 Consumables Kit, P/N 54-CK-100.	
<b>2100</b>	<b>2131</b>	1.22 (30.9mm)	1.15" (29.2mm)	1.04" (26.4mm)	1.36" (34.5mm)	Bruker, Fisons, Kevex, Oxford, Panalytical, Rigaku, Spectrace, Spectro (Phoenix, XEPOS, iQ II and other Systems), Thermo, Xenometrix		
	<b>2132</b>							1.24" (31.5mm)
	<b>2135</b>	1.35" (34.3mm)	1.17" (29.7mm)	1.10" (27.9mm)	1.46" (37.1mm)	Panalytical (MiniPal) & Epilison 3XL		
	<b>2140</b>	1.58" (40.1mm)	1.17" (29.7mm)	1.38" (35.0mm)	1.70" (43.2mm)	ARL, Bruker (Manual S2 and S4 Systems), Kevex, Oxford, Panalytical, Rigaku Mini Z, Spectrace, Spectro, Thermo		
	<b>2143</b>	1.58" (40.1mm)	1.17" (29.7mm)	1.38" (35.0mm)	1.62" (41.1mm)	Bruker Automatic S-2 with XFlash® Detector and S-8 with FLEX loader		
	<b>2144</b>	1.58" (40.1mm)	1.33" (33.8mm)	1.38" (35.0mm)	1.62" (41.1mm)			
	<b>2145</b>	1.76" (44.7mm)	1.16" (29.5mm)	1.57" (39.9mm)	1.81" (46.0mm)	Panalytical Epsilon 5; And other models PANalytical Axios		
	<b>2146</b>	1.76" (44.7mm)	1.32" (33.5mm)	1.57" (39.9mm)	1.81" (46.0mm)			
	<b>2147</b>	1.76" (44.7mm)	1.16" (29.5mm)	1.57" (39.9mm)	1.85" (46.9mm)	Thermo Scientific Advant'X		
	<b>2148</b>	1.76" (44.7mm)	1.32" (33.5mm)	1.57" (39.9mm)	1.85" (46.9mm)			
<b>2195</b> (See 1095)	1.71" (43.4mm)	1.56" (39.6)	1.50" (38.1mm)	1.77" (45.0mm)	Rigaku Primus, Panalytical Venus 200			
<b>3100</b>	<b>3106</b>	1.20" (30.5mm)	0.99" (25.1mm)	0.24" (6.1mm)	N/A	Meterox, Panalytical, Rigaku, Spectro, Thermo, Xenometrix and other instruments accommodating 32 mm diameter sample cups and micro sample analysis		
	<b>3110</b>							0.39" (9.9mm)
	<b>3115</b>							0.59" (15.0mm)
	<b>3120</b>							0.79" (20.0mm)

Sample Cups and Accessories
Thin-Film Sample Supports
Grinding Machines and Accessories
Briquetting Presses and Accessories
Grinding/Briquetting Additives
Fusion Machines and Accessories
Standards and XRF/XRD Chemical Kits

**SERIES 1000:**

**SpectroSulfur® Analyzer  
TrimLess® XRF Sample Cups**

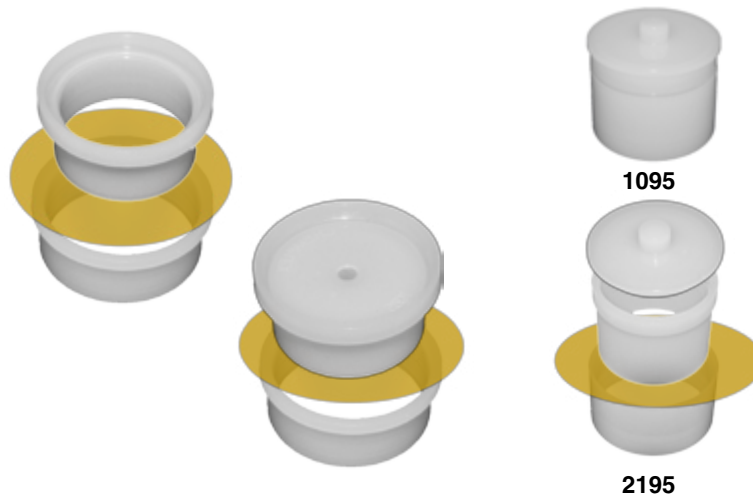

The TrimLess® sample cup catalog number 1095 is a double open-ended cell and includes a vented cap with a knob. An alternate to this sample cup is SpectroCup® Integrated Internal Overflow Reservoir design that collects over-fills within the cell; for complete product specifications see SpectroCup Cat. No: [2195](#). Both styles are comparable in use and applications for Rigaku, Panalytical Venus 200 systems and other x-ray units with sample cup holders accepting similar dimensions.

Choice of double open-ended Cell for pre-attaching thin-film sample support windows, top sample filling and use in inert helium flush or atmospheric pressure.

Integrated flange on outer Cell neck diameter physically defines the distance of TrimLess® Sleeve travel over the Cell during the thin-film sample support window attachment procedure ensuring reproducible sample cup assemblies and statistically accurate x-ray data.

Choice of single-open ended Cell with Integrated External Overflow Reservoir and puncturable ThermoPlastic® Seal for pressure equalization within the sample cup and sample chamber to maintain taut thin-film sample support planes.

Extra wide TrimLess® Sleeve envelopes extraneous thin-film sample support window material to eliminate trimming excess and dealing with annoying static prone clippings.

CAT. NO.	DESCRIPTION	OUTSIDE DIA.	MAXIMUM OD	HEIGHT	APERTURE	CAPACITY, cc	SETS/PKG
1060 <sup>1</sup>	Double open end	1.23" (31.2mm)	N/A	0.93" (23.6mm)	0.96" (24.4mm)	9	100
1065 <sup>1</sup>	Single open end	1.23" (31.2mm)	N/A	0.93" (23.6mm)	0.96" (24.4mm)	8	100
1070 <sup>1</sup>	Double open end	1.52" (38.6mm)	N/A	0.90" (22.9mm)	1.19" (30.2mm)	13	100
1075 <sup>1</sup>	Single open end	1.51" (38.4mm)	N/A	0.90" (22.9mm)	1.21" (30.7mm)	13	100
1080 <sup>2</sup>	Double open end	1.69" (42.9mm)	1.84" (46.7 mm)	0.80" (20.3mm)	1.43" (36.3mm)	15	100
1083 <sup>2</sup>	Single open end	1.69" (42.9mm)	1.84" (46.7m)	0.73" (18.5mm)	1.43" (36.3mm)	12	100
1085 <sup>2</sup>	Single open end	1.69" (42.9mm)	1.84" (46.7mm)	0.80" (20.3 mm)	1.43" (36.3mm)	12	100
1095 <sup>3</sup> (See <a href="#">2195</a> alternative)	Double open end with vented cap with knob	1.71" (43.4mm)	1.76" (44.6 mm)	1.57" (39.9mm)	1.50" (38.1mm)	30	100

Made under one or more of patents: 5,630,989 and pending applications

© ThermoPlastic, SpectroSulfur, TrimLess, Chemplex & are registered trademarks of Chemplex Inds., Inc.

<sup>1</sup> Spectro Xepos, X-Lab 2000, Xepos Low S, 200, 200T Titan, Phoenix instruments

<sup>1</sup> Xenometrix X-Calibur, X-Cite

<sup>2</sup> Other Instruments Applicable to Sulfur Analysis in Petroleum Product (send for free assortment)

<sup>3</sup> Panalytical Venus 200 and Rigaku Primus series, ZSX-100 and Rix series instruments. See [2195](#) sample cups as alternatives.

Sample Cups and Accessories
Thin-Film Sample Supports
Grinding Machines and Accessories
Briquetting Presses and Accessories
Grinding/Briquetting Additives
Fusion Machines and Accessories
Standards and XRF/XRD Chemical Kits

**COMBINATION SERIES: 1000 & 1850**

**SpectroSulfur® Analyzer XRF Sample Cups**



Cat. No: **1080**

Cat. No: **1083 and 1085**

Cat. No: **1850**

For convenience of locating sample cups used with sulfur or chlorine analyzers, SpectroSulfur® analyzer sample cups are also combined into a separate combination series. The original catalog numbers of the sample cups remained unchanged as well as their listing under their respective series.

**TrimLess® Thin-Film Window Attachments: Cat. No: 1080, 1083 & 1085**

As the name implies, thin-film window attachment requires no trimming and contending with annoying static cling. The provided collar secures the thin-film in position with complete envelopment.

**Two versions are offered:**

Cat. No: **1080** is open on both ends for preparing sample cups in advance with thin-film windows and allow samples to be conveniently introduced from the top.

Cat. No: **1083** and **1085** are closed on one end and also integrate an external overflow reservoir and ThermoPlastic® venting option. The two sample cups are identical with the exception of their heights. The 1083 is approximately 3 mm less in height for accommodation by sulfur analyzers designed with a sample cup holder lid that requires a smaller sample cup height.

**Low-Profile SpectroSulfur® Analyzer XRF Sample Cups; Cat. No: 1850**

The **1850** sulfur analyzer sample cups are used with XOS Sindie® sulfur analyzers and other sulfur analyzer instruments requiring a specially configured Low-Profile design. The 1850 SpectroSulfur® analyzer sample cup is open on one end and integrates an external overflow reservoir with ThermoPlastic® user venting option. Thin-film windows are firmly attached by means of a uniquely designed “bead-to-indent” geometry incorporated in the “Snap-On Ring” and Cell neck.

CAT. NO.	DESCRIPTION	OUTSIDE DIA.	MAXIMUM OD	HEIGHT	APERTURE	CAPACITY, cc	SETS/PKG
<b>1080</b>	SpectroSulfur®	1.69"	1.84"	0.80"	1.43"	15	100
		(42.9mm)	(46.7 mm)	(20.3mm)	(36.3mm)		
<b>1083</b>	Analyzer	1.69"	1.84"	0.73"	1.43"	12	100
		(42.9mm)	(46.7mm)	(18.5 mm)	(36.3mm)		
<b>1085</b>	Sample Cups	1.69"	1.84"	0.80"	1.43"	12	100
		(42.9mm)	46.7 mm)	(20.3 mm)	(36.3mm)		
<b>1850</b>		1.69"	1.87"	0.77"	1.41"	13	100
		(42.9mm)	(47.5 mm)	(19.6mm)	(35.8mm)		

© Sindie is a registered trademark of X-Ray Optical Systems, Inc.

© SpectroSulfur, SpectroMembrane, ThermoPlastic, TrimLess and Chemplex are registered trademarks of Chemplex Industries, Inc.

- Sample Cups and Accessories
- Thin-Film Sample Supports
- Grinding Machines and Accessories
- Briquetting Presses and Accessories
- Grinding/Briquetting Additives
- Fusion Machines and Accessories
- Standards and XRF/XRD Chemical Kits

## SERIES 1300:

### XRF Sample Cup Overflow Reservoir Cap Optionally Sealable or Ventable

#### CHOICE OF INTEGRATED SERRATED THIN-FILM WINDOW TRIMMERS



Assembled Cup and Cap form a series of internal baffles that reduce sample particle disruption.

Re-sealable cap integrates an external overflow reservoir and offers the option for venting. With the re-sealable cap rotated in the open position, an evacuation passageway is established from the within the Cell to the integrated overflow reservoir and sample chamber. By re-positioning the cap, the passageway is closed for storage and future referral.

The Cell and “Snap-On Ring” incorporate the Chemplex developed “bead-to-indent” geometry responsible for forming taut thin-film window planes and leak-resistant seals.

Alternatively available 32 mm diameter sample cups with integrated serrated edged “Snap-On Rings” allow extraneous thin-film trimming close to the sample cup. Order by catalog number followed by “SE”.



CAT. NO.	DESCRIPTION	OUTSIDE DIAMETER	HEIGHT	APERTURE	CAPACITY cc	SETS/PKG
1330 <sup>1</sup>	Double open ends	1.21” (30.7mm)	0.90” (22.9mm)	0.97” (24.6mm)	7	100
1330-SE <sup>1</sup>	“Snap-On Rings” with Integrated Thin-Film Trimmer					
1340	Double open ends	1.54” (39.1mm)	0.91” (23.1mm)	1.26” (32.0mm)	12	100

Reg. US Patent US 7,981, 380

<sup>1</sup> Innov-X (Hand Held Unit)

<sup>1</sup> Spectro Xepos, X-Lab 2000, Xepos Low S, 200, 200T Titan, Phoenix instruments

<sup>1</sup> Xenometrix X-Calibur, X-Cite

Sample Cups and Accessories
Thin-Film Sample Supports
Grinding Machines and Accessories
Briquetting Presses and Accessories
Grinding/Briquetting Additives
Fusion Machines and Accessories
Standards and XRF/XRD Chemical Kits

**SERIES 1400:**  
**XRF Sample Cup Single Open-Ended Offers Micro Sample Mounting**  
**CHOICE OF INTEGRATED SERRATED THIN-FILM WINDOW TRIMMERS**



Flexible in use as a single open-ended sample cup or for micro sample mounting

Cell integrates two puncturable ThermoPlastic® seals for equalizing pressure differentials within the sample cup and sample chamber. The off-centered ThermoPlastic® seal is optionally usable for venting when a micro sample is contained within a capillary tube or affixed at the end of a glass rod.

The Collar provided pre-affixes a thin-film substrate to the Cell in preparation for attaching the furnished locking “Snap-On Ring”. Alternatively, a pre-attached thin-film may be used to support evaporated droplets or micro powdered samples for thin-layered preparations enveloped in between another thin-film with both secured in place by the attachment of the included “Snap-On Ring.”

The “Snap-On Ring” and Cell neck utilize the unique Chemplex “bead-to-indent” geometry responsible for firmly securing thin-film sample support window planes to the sample cup Cell. In combination they form wrinkle-free sample planes and leak-resistant seals.

Internal receptacle accepts a user provided capillary tube containing micro samples or a solid substance or internal reference standard mounted on a solid rod. Inside diameter of the receptacle is 0.157” (3.98 mm).

Alternatively available in 32 mm diameter sample cups with integrated serrated edged “Snap-On Rings” that allow extraneous thin-film trimming close to the sample cup. Order by catalog number followed by “SE”.

CAT. NO.	DESCRIPTION	OUTSIDE DIAMETER	HEIGHT	APERTURE	CAPACITY, cc	SETS/PKG
1430 <sup>1</sup>	Single open end; ThermoPlastic® Seal Venting	1.22” (31.0mm)	0.88” (22.4mm)	0.97” (24.6mm)	9	100
1430-SE <sup>1</sup>	“Snap-On Rings” with Integrated Thin-Film Trimmer					
1440 <sup>1</sup>	Single open end; ThermoPlastic® Seal Venting	1.55” (39.4mm)	0.88” (22.3mm)	1.27” (32.3mm)	15	100
1440L <sup>2</sup>	Single open end for Replacement of Oxford 54-LX6922 sample cups	1.55” (39.4mm)	1.38” (35.1mm)	1.28” (32.5mm)	25	100

Reg. US Patent US 7,981, 380.

©ThermoPlastic, TrimLess and Chemplex are registered trademarks of Chemplex Industries, Inc.

**IMPORTANT:** The provided Collar must clear the serrated Snap-On Ring when using the 1430-SE Sample Cups

<sup>1</sup> Spectro Xepos, X-Lab 2000, Xepos Low S, 200, 200T Titan, Phoenix instruments

<sup>1</sup> Xenometrix X-Calibur, X-Cite

<sup>2</sup> Replacement for Oxford sample cups Cat. No: 54-LX6922

- Sample Cups and Accessories
- Thin-Film Sample Supports
- Grinding Machines and Accessories
- Briquetting Presses and Accessories
- Grinding/Briquetting Additives
- Fusion Machines and Accessories
- Standards and XRF/XRD Chemical Kits

**SERIES 1500:**

**XRF Sample Cup with Microporous Film and Ventable Sample Cup Cap Attachment Provision**

**CHOICE OF INTEGRATED SERRATED THIN-FILM WINDOW TRIMMERS**



1500 Series Sample Cup with optionally available [Microporous Film](#) for equalizing pressure differentials within the sample cup and sample chamber.

One of two supplied “Snap-On Rings” allows Microporous Film attachment to the upper Cell neck for pressure equalization within the sample cup and sample chamber. [Microporous Film](#) is attached to the upper end of the Cell Neck with a ridge. Alternatively, a “Vented Sample Cup Cap,” [1600 Series](#), may be similarly used to maintain pressure equalization.

The second “Snap-On Ring” is used to attach a thin-film window to the lower end of the Cell. Both “Snap-On Rings” are designed with a “bead-to-indent” geometry for establishing taut and leak-resistant sample windows.

Alternatively available in 32 mm diameter sample cups with integrated serrated edged “Snap-On Rings” that allow extraneous thin-film trimming close to the sample cup. Order by catalog number followed by “SE”.

XRF Sample Cup illustrated with optionally available [Microporous Film](#) for equalizing pressure differentials within the sample cup and sample chamber.



1500 Series Sample Cup with optionally available [Sample Cup Cap](#) for equalizing pressure differentials within the sample cup and sample chamber.



CAT. NO.	DESCRIPTION	OUTSIDE DIAMETER	HEIGHT	APERTURE	CAPACITY, cc	SAMPLE CUP CAP CAT. NO.	SETS/PKG
1530	Double open ends	1.22" (31.0mm)	0.91" (23.1mm)	0.94" (23.9mm)	9	<a href="#">1630</a>	100
1530-SE	“Snap-On Rings” with Integrated Thin-Film and Microporous Film Trimmer						
1540	Double open ends	1.55" (39.4mm)	0.91" (23.1mm)	1.22" (31.0mm)	16	<a href="#">1640</a>	100

Reg. US Patent US 7,981, 380

**IMPORTANT:** When using 1530SE, Microporous Film must be used on the open end with the flange on the Cell.

Spectro Xepos, X-Lab 2000, Xepos Low S, 200, 200T Titan, Phoenix instruments

Xenometrix X-Calibur, X-Cite

Sample Cups and Accessories
Thin-Film Sample Supports
Grinding Machines and Accessories
Briquetting Presses and Accessories
Grinding/Briquetting Additives
Fusion Machines and Accessories
Standards and XRF/XRD Chemical Kits

**SERIES 1600:**

**XRF Sample Cup Slit-Vented “Snap-On” Caps**

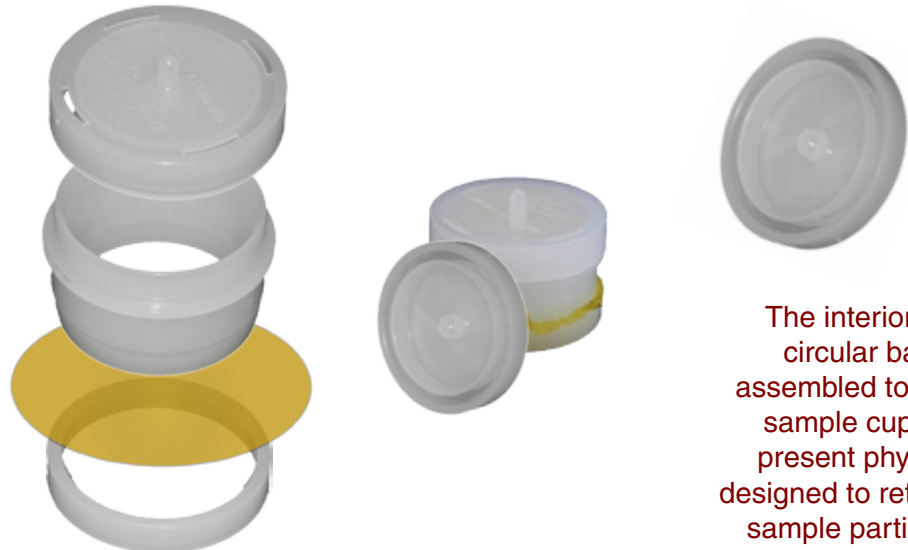

The interior ridges form circular baffles when assembled to a 1500 Series sample cup. The baffles present physical barriers designed to retard or eliminate sample particle disruption.

Vented Sample Cup Caps are unlike traditional caps with vented holes. These innovative caps are specifically designed to form a series of circular physical barriers when attached to a [1500 Series XRF Sample Cup](#). The barriers are created by the inter-relationship between integrated ridges on the interior of the cap and the Cell Neck when assembled. This forms circular troughs representing passageways leading from the interior of the sample cup to the sample chamber. The barriers present complicated paths of travel for sample particles to reach the sample chamber. Slit-Venting is used instead of traditional holes in order to increase the volumetric quantity of air withdrawal with minimum disturbances to the sample substance while maintaining taut thin-film sample window planes.

The Slit Vented “Snap-On” Caps are affixed to the upper open end of the Cell containing a ridge and after the thin-film window has been attached and the sample introduced. The Caps are designed with the same Chemplex developed “bead-to-indent” geometry of the “Snap-On Rings” for affixing thin-film window sample planes.

The “Snap-On Rings” supplied with the 1500 Series sample cups are also designed with a “bead-to-indent” geometry for safely securing a sample with a taut thin-film sample support window plane.

CAT. NO.	DESCRIPTION	NOMINAL OUTSIDE DIAMETER mm	USE WITH LISTED CAT. NO. OF SAMPLE CUP	CAPS/PKG
1630	Vented Sample Cup Caps	32	For Use with: <a href="#">1530</a> Sample Cups	100
1640		40	For Use with: <a href="#">1540</a> Sample Cups	100

- Sample Cups and Accessories
- Thin-Film Sample Supports
- Grinding Machines and Accessories
- Briquetting Presses and Accessories
- Grinding/Briquetting Additives
- Fusion Machines and Accessories
- Standards and XRF/XRD Chemical Kits

**SERIES 1700:**  
**XRF Sample Cup “Snap-Post” Facilitates Venting and Collecting Thermally Sensitive Liquids in External Overflow Reservoir**  
**CHOICE OF INTEGRATED SERRATED THIN-FILM WINDOW TRIMMERS**



Venting just requires jiggling the “Snap-Post” to rupture the ThermoPlastic® seal.

Venting is performed by simply jiggling the “Snap-Post” integrated with the ThermoPlastic® seal from side to side. The seal is automatically ruptured permitting a direct passageway from within the sample cup to the sample chamber. Pressure equalization is established that maintains a flat taut sample support window plane. The Integrated External Overflow Reservoir collects thermally sensitive liquids having tendencies to expand.

The Collar provided pre-affixes a thin-film substrate to the Cell in preparation for attaching the furnished locking “Snap-On Ring.” Alternatively, a pre-attached thin-film may be used to support evaporated droplets or micro powdered samples for thin-layered preparations enveloped in between another thin-film with both secured in place by the attachment of the included “Snap-On Ring.”

The “Snap-On Ring” and Cell neck utilize the unique Chemplex “bead-to-indent” geometry responsible for firmly securing thin-film sample support window planes to the sample cup Cell. In combination they form wrinkle-free sample planes and leak-resistant seals.

Alternatively available in 32 mm diameter sample cups with integrated serrated edged “Snap-On Rings” that allow extraneous thin-film trimming close to the sample cup. Order by catalog number followed by “SE”.

CAT. NO.	DESCRIPTION	OUTSIDE DIAMETER	HEIGHT	APERTURE	CAPACITY, cc	SETS/PKG
1730	“Snap-Post” Venting	1.21” (30.7mm)	0.91” (23.1mm)	0.97” (24.6mm)	7	100
1730-SE	“Snap-On Rings” with Integrated Thin-Film Trimmer					
1740	“Snap-Post” Venting	1.54” (39.1mm)	0.93” (23.6mm)	1.26” (32.0mm)	11	100

Reg. US Patent US 7,981, 380.

® ThermoPlastic, SpectroMembrane and Chemplex are registered trademarks of Chemplex Industries, Inc.

**IMPORTANT:** The provided Collar must clear the serrated Snap-On Ring when using the 1730-SE Sample Cups

- Sample Cups and Accessories
- Thin-Film Sample Supports
- Grinding Machines and Accessories
- Briquetting Presses and Accessories
- Grinding/Briquetting Additives
- Fusion Machines and Accessories
- Standards and XRF/XRD Chemical Kits

**SERIES 1800:**

**XRF Sample Cups Collect Thermally Sensitive Liquids in Ventable External Overflow Reservoir**  
**CHOICE OF INTEGRATED SERRATED THIN-FILM WINDOW TRIMMERS**

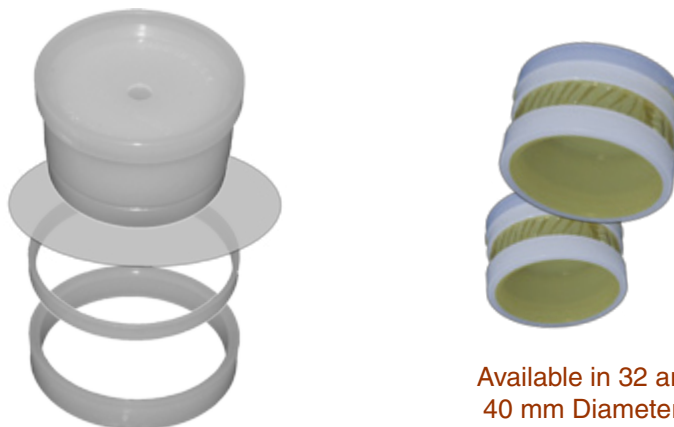

The upper portion of the Cell is formed with a recession that serves as an external overflow reservoir for collecting and retaining thermally sensitive liquid samples. An easily rupturable ThermoPlastic® seal is centrally located to form a passageway from within the sample cup directly to the external overflow reservoir. Pressure equalization is easily established and maintained for taut thin-film sample support sample planes.

The Collar provided pre-affixes a thin-film substrate to the Cell in preparation for attaching the furnished locking “Snap-On Ring.” Alternatively, a pre-attached thin-film may be used to support evaporated droplets or micro powdered samples for thin-layered preparations enveloped in between another thin-film with both secured in place by the attachment of the included “Snap-On Ring.”

The “Snap-On Ring” and Cell neck utilize the unique Chemplex “bead-to-indent” geometry responsible for firmly securing thin-film sample support window planes to the sample cup Cell. In combination they form wrinkle-free sample planes and leak-resistant seals.

Alternately available in 32 mm diameter sample cups with integrated serrated edged “Snap-On Rings” that allow extraneous thin-film trimming close to the sample cup. Order by catalog number followed by “SE”.

CAT. NO.	DESCRIPTION	OUTSIDE DIAMETER	HEIGHT	APERTURE	CAPACITY, cc	SETS/PKG
1830	ThermoPlastic® Seal Venting	1.22" (31.0mm)	0.87" (22.1mm)	0.96" (24.4mm)	7	100
1830-SE	“Snap-On Rings” with Integrated Thin-Film Trimmer					
1840	ThermoPlastic® Seal Venting	1.54" (39.1mm)	0.93" (23.6mm)	1.25" (31.8mm)	12	100

Reg. US Patent US 7,981, 380.

© ThermoPlastic, SpectroMembrane and Chemplex are registered trademarks of Chemplex Industries, Inc.

**IMPORTANT:** The provided Collar must clear the serrated Snap-On Ring when using the 1830-SE Sample Cups Spectro Xepos, X-Lab 2000, Xepos Low S, 200, 200T Titan, Phoenix instruments Xenometrix X-Calibur, X-Cite

- Sample Cups and Accessories
- Thin-Film Sample Supports
- Grinding Machines and Accessories
- Briquetting Presses and Accessories
- Grinding/Briquetting Additives
- Fusion Machines and Accessories
- Standards and XRF/XRD Chemical Kits

**SERIES 1850:**

**SpectroSulfur® Analyzer Low-Profile XRF Sample Cups**



**Low Profile SpectroSulfur® Analyzer Sample Cups for Sulfur Analyzer Sample Holders with Limited Height**

The Chemplex designed “Snap-On Ring” and Cell “bead-to-indent” geometry is responsible for this Low Profile sample cup forming taut thin-film sample support planes and leak-resistant seals.

The closed end integrates an external overflow reservoir for collecting thermally sensitive fluid samples with tendencies to expand.

The easily rupturable ThermoPlastic® seal provides a venting passageway leading to the integrated external overflow reservoir. Pressure differentials between the interior of the sample cup and sample chamber are equalized for taut thin-film sample support window planes.

The Low Profile shape enables accommodation by some instrument sample holders with limited height provision.

**SpectroSulfur® Analyzer Sample Cups for XOS “Sindie®” Instruments and Other Sulfur in Oil Analyzers**

CAT. NO.	DESCRIPTION	OUTSIDE DIAMETER	MAXIMUM OD	HEIGHT	APERTURE	CAPACITY cc	SETS/PKG
1850	<b>SPECTROSULFUR® LOW-PROFILE ANALYZER SAMPLE CUPS</b>	1.69” (42.9mm)	1.87” (47.5mm)	0.77” (19.6mm)	1.41” (35.8mm)	13	100

Industries, Inc.

® Sindie is a registered trademark of X-Ray Optical Systems, Inc.

® SpectroSulfur, SpectroMembrane®, ThermoPlastic, the Wizard character and Chemplex are registered trademarks of Chemplex

Sample Cups and Accessories
Thin-Film Sample Supports
Grinding Machines and Accessories
Briquetting Presses and Accessories
Grinding/Briquetting Additives
Fusion Machines and Accessories
Standards and XRF/XRD Chemical Kits

**SERIES 1900:**

**XRF Sample Cup with Double Open-End Offers Convenient Top Sample Filling**

**CHOICE OF INTEGRATED SERRATED THIN-FILM WINDOW TRIMMERS**



Double open-ended Cell facilitates sample introduction by filling from the top end. Prepare multiple samples cups in advance with thin-film sample support windows prior to filling. Ideally suitable for non-volatile liquid and loose powdered materials in helium flush or atmospheric conditions.

The Collar provided pre-affixes a thin-film substrate to the Cell in preparation for attaching the furnished locking “Snap-On Ring.” Alternatively, a pre-attached thin-film may be used to support evaporated droplets or micro powdered samples for thin-layered preparations enveloped in between another thin-film with both secured in place by the attachment of the included “Snap-On Ring.”

The “Snap-On Ring” and Cell neck utilize the unique Chemplex “bead-to-indent” geometry responsible for firmly securing thin-film sample support window planes to the sample cup Cell. In combination they form wrinkle-free sample planes and leak-resistant seals.

Alternatively available 32 mm diameter sample cups with integrated serrated edged “Snap-On Rings” that allow extraneous thin-film trimming close to the sample cup. Order by catalog number followed by “SE”.

CAT. NO.	DESCRIPTION	OUTSIDE DIAMETER	HEIGHT	APERTURE	CAPACITY CC	SETS/PKG
1930 <sup>1</sup>	Double open ended	1.23” (31.2mm)	0.84” (21.3mm)	0.96” (24.4mm)	8	100
1930-SE <sup>1</sup>	“Snap-On Rings” with Integrated Thin-Film Trimmer					
1940 <sup>1</sup>	Double open ended	1.55” (39.4mm)	0.84” (21.3mm)	1.27” (32.3mm)	15	100
1940L <sup>2</sup>	Double open ended	1.55” (39.4mm)	1.39” (35.3mm)	1.27” (32.3mm)	25	100

Reg. US Patent US 7,981, 380 B2.

**IMPORTANT:** The provided Collar must clear the serrated Snap-On Ring when using the 1930-SE Sample Cup

<sup>1</sup> Spectro Xepos, X-Lab 2000, Xepos Low S, 200, 200T Titan, Phoenix instruments

<sup>1</sup> Xenometrix X-Calibur, X-Cite

<sup>2</sup> Oxford Lab-X instruments

Sample Cups and Accessories
Thin-Film Sample Supports
Grinding Machines and Accessories
Briquetting Presses and Accessories
Grinding/Briquetting Additives
Fusion Machines and Accessories
Standards and XRF/XRD Chemical Kits

**SERIES 1935-OX:**

**DOUBLE OPEN-ENDED 31 mm XRF SAMPLE CUPS INCLUDING FRICTION FITTING VENTED CAP EXTERNAL OVERFLOW RESERVOIR FOR OXFORD ANALYZERS**

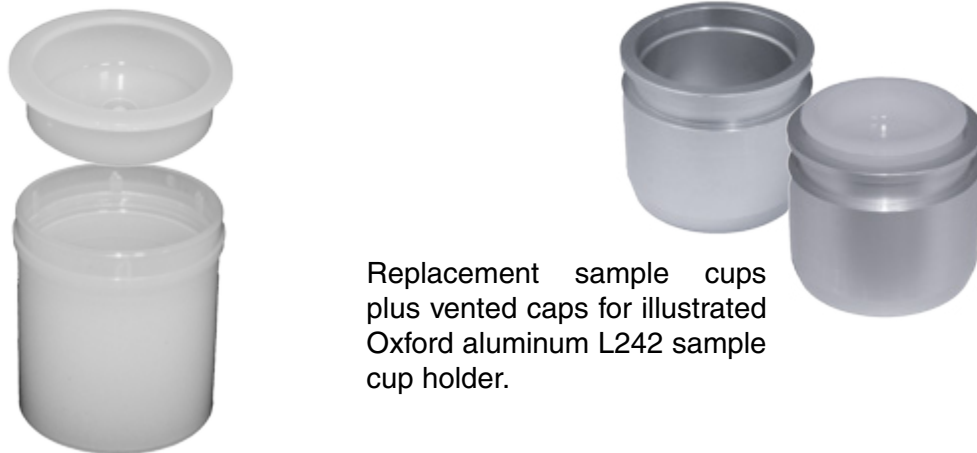

Replacement sample cups plus vented caps for illustrated Oxford aluminum L242 sample cup holder.

Vented friction-fitting cap equalizes pressure differentials within assembled sample cup. Integrated external overflow reservoir captures thermally sensitive liquid samples.

Integrated upper Cell flange physically prevents Cell from uncontrollable retraction or protrusion from the lower edge of the aluminum sample holder. Averts re-preparations and ensures reproducible x-ray data.

Close manufacturing tolerances enable and facilitate insertion and particularly removal from aluminum sample holder. Use with Oxford x-ray analyzers requiring user L240 aluminum sample cup holders with interior "O" ring seals.

CAT. NO.	DESCRIPTION	OUTSIDE DIAMETER	HEIGHT	APERTURE	CAPACITY, cc	CAPS INCLUDED	SETS/PKG
1935-OX	Replacement Cells and Covers for Oxford CK-100 Consumables Kit, P/N 54-CK-100; Models: LAB X & MDX	1.23" (31.2mm)	1.51" (38.4mm)	1.16" (29.5mm)	17	100	100

Sample Cups and Accessories
Thin-Film Sample Supports
Grinding Machines and Accessories
Briquetting Presses and Accessories
Grinding/Briquetting Additives
Fusion Machines and Accessories
Standards and XRF/XRD Chemical Kits

**SERIES 2100:**

**SpectroCup® Internal Overflow Reservoir Sample Cups  
VENTED “SNAP-ON” CAP and TRIMLESS® THIN-FILM SLEEVE ATTACHMENT**

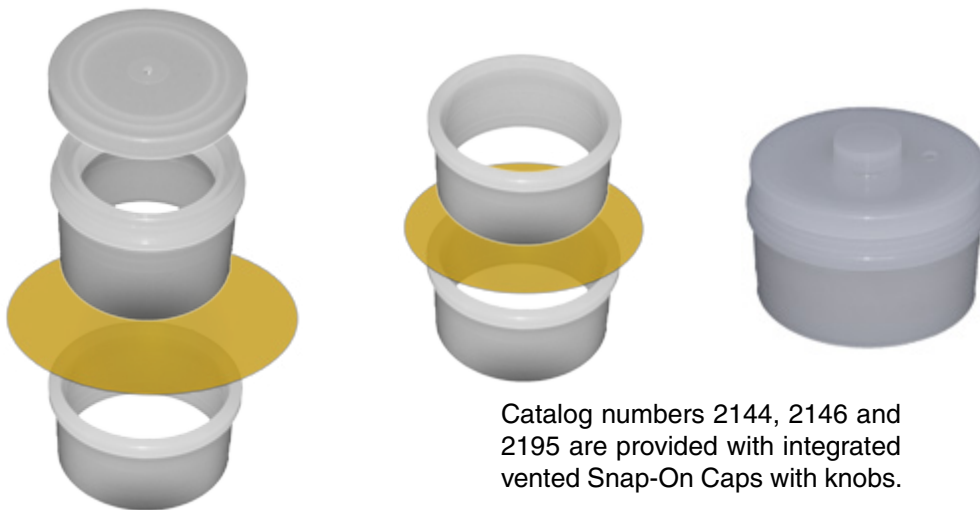

Catalog numbers 2144, 2146 and 2195 are provided with integrated vented Snap-On Caps with knobs.

Snap-On Cap establishes a series of physical baffles that provide resistance to powdered sample withdrawal under evacuated conditions. Vent hole equalizes pressure differentials within the sample cup and sample chamber under helium flushes and vacuum operating conditions.

Cell integrates an Internal Overflow Reservoir for collecting thermally sensitive liquid samples within the sample cup reducing the likelihood of inadvertent spillage into the sample chamber; serves as a filling level guide for uniformity of sample volume.

Integrated flange on outer cell neck diameter physically defines the distance of TrimLess® Sleeve travel over the Cell during the thin-film sample support window attachment procedure; ensures reproducible sample cup assemblies and statistically accurate x-ray data.

Extra wide TrimLess® Sleeve envelopes extraneous thin-film sample support window material to eliminate trimming excess and dealing with annoying static prone clippings.

Cat. No.	Outside Dia.	Max. Dia.	Height	Aperture	Knob Cap	Capacity	Sets/Pkg
2131 <sup>1</sup>	1.22" (30.9mm)	1.36" (34.5mm)	1.15" (29.2mm)	1.04" (26.4mm)	No	9 *	100
2132 <sup>2</sup>	1.24" (31.5mm)	1.36" (34.5mm)	1.15" (29.2mm)	1.04" (26.4mm)	No	9 *	100
2135 <sup>3</sup>	1.35" (34.3mm)	1.46" (37.1mm)	1.17" (29.7mm)	1.10" (27.9mm)	No	11 *	100
2140 <sup>4</sup>	1.58" (40.1mm)	1.70" (43.2 mm)	1.17" (29.7mm)	1.38" (35.0mm)	No	19 *	100
2143 <sup>5</sup>	1.58" (40.1mm)	1.62" (41.1mm)	1.17" (29.7mm)	1.38" (35.0mm)	No	19 *	100
2144 <sup>6</sup>	1.58" (40.1mm)	1.62" (41.1mm)	1.33" (33.8mm)	1.38" (35.0mm)	Yes	19 *	100
2145 <sup>7</sup>	1.76" (44.7mm)	1.81" (46.0mm)	1.16" (29.5mm)	1.57" (39.9mm)	No	22 *	100
2146 <sup>8</sup>	1.76" (44.7mm)	1.81" (46.0mm)	1.32" (33.5mm)	1.57" (39.9mm)	Yes	22 *	100
2147 <sup>10</sup>	1.76" (44.7mm)	1.85" (46.9mm)	1.16" (29.5mm)	1.57" (39.9mm)	No	22 *	100
2148 <sup>11</sup>	1.76" (44.7mm)	1.85" (46.9mm)	1.32" (33.5mm)	1.57" (39.9mm)	Yes	22 *	100
2149 <sup>12</sup>	1.76" (44.7mm)	1.81" (46.0mm)	1.54" (39.2mm)	1.57" (39.9mm)	Yes	22 *	100
2195 <sup>9</sup>	1.71" (43.4mm)	1.77" (45.0mm)	1.56" (39.6mm)	1.50" (38.1mm)	Yes	22 *	100

® SpectroCup, SpectroMembrane, TrimLess & Chemplex are registered trademarks of Chemplex Industries, Inc.

Reg. US Patent No: 8,043,862

<sup>1</sup> Cat. No. 2131: Spectro Phoenix II instruments and other systems requiring less than 31 mm diameter cups

<sup>1,2</sup> Cat. No: 2131, 2132: Xenometrix X-Calibur, X-Cite

<sup>2</sup> Cat. No. 2132: Spectro XEPOS, iQ and other systems of similar sample cup holder dimensions

<sup>3</sup> Cat. No. 2135: PANalytical MiniPal, Epsilon 3XL and other systems of similar sample cup holder dimensions

<sup>4</sup> Cat. No. 2140: manual Bruker S2 and S4 and Rigaku Mini-Z Series

<sup>5</sup> Cat. No. 2143: automatic Bruker S2 with XFlash® Detector and S8 with FLEX loader

<sup>6</sup> Cat. No. 2144: same as 2143 except for inclusion of a knob integrated in the vented cap.

<sup>7</sup> Cat. No. 2145: PANalytical Epsilon 5 and other models for 46 mm diameters; see 2146 for a vented cap with a knob

<sup>8</sup> Cat. No. 2146: same as 2145 except for inclusion of a knob integrated in the cap for PANalytical Axios instrumentation.

<sup>9</sup> Cat. No. 2195 is an Internal Overflow Reservoir featured alternative for Cat. No. 1095; For Rigaku Primus series, ZSX-100 and Rix series and Panalytical Venus 200 and other instrument sample cup holders of similar dimensions with vented caps with knobs.

<sup>10</sup> Cat. No. 2147: Thermo Scientific AdvantX and other models for 46 mm diameters; see 2148 for a vented cap with a knob.

<sup>11</sup> Cat. No. 2148: same as 2147 except for inclusion of a knob integrated in the cap for Thermo Scientific AdvantX instrumentation.

<sup>12</sup> Cat. No. 2149: includes a total of 4 vent provisions integrated in the cap for PANalytical Axios instrumentation.

- Sample Cups and Accessories
- Thin-Film Sample Supports
- Grinding Machines and Accessories
- Briquetting Presses and Accessories
- Grinding/Briquetting Additives
- Fusion Machines and Accessories
- Standards and XRF/XRD Chemical Kits

**SERIES 3100:**

**SpectroMicro® Sample Cups Utilize "FunnelShape™" Technology**

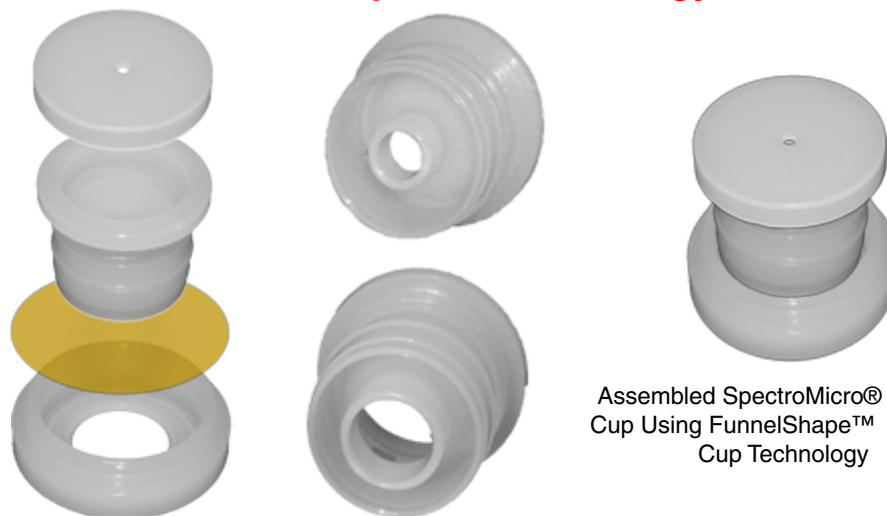

Assembled SpectroMicro® Sample Cup Using FunnelShape™ Sample Cup Technology

Vented Snap-On Cap equalizes pressure differentials within the Cell and sample chamber to maintain a taut thin-film sample support plane.

Cell interior integrates a FunnelShape™ configuration for introducing and containing powdered, solid or liquid sample substances. The larger conically shaped upper portion of the funnel allows and facilitates sample introduction. The lower cylindrically shaped spout of the funnel represents the actual sample chamber and its diameter is expressed as the aperture. Select sample cup size by matching the aperture diameter to the volume of sample available for analysis.

The Collar is used to secure a thin-film sample support window substance to the Cell and designed for acceptance by 32 mm sample cup holders.

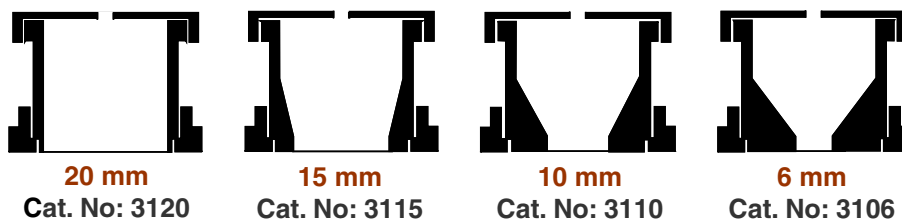

Select the diameter of the aperture from the catalog number. The last two digits of the catalog number reflect the aperture diameter of the SpectroMicro® sample cup funnel. The funnel configuration guides the sample toward the thin-film sample window.

Catalog Number	Surface Area Exposure Diameter	Sample Chamber Volumetric Capacity	Outside Diameter	Height (With Cap)	Integrated Interior Funnel	Number of Sample Cup Sets/Package*
3106	6 mm (0.24")	0.20 cc	30.5 mm (1.20")	25.1 mm (0.99")	Yes	100
3110	10 mm (0.39")	0.50 cc	30.5 mm (1.20")	25.1 mm (0.99")	Yes	100
3115	15 mm (0.59")	1.00 cc	30.5 mm (1.20")	25.1 mm (0.99")	Yes	100
3120	20 mm (0.79")	5.50 cc	30.5 mm (1.20")	23.1 mm (0.91")	N/A	100

Note: A set consists of a cell, vented cap and collar

Registered U.S. Patent No: 8,404,197

Made under one or more of patents: 5,630,989; 4,698,210; 238,210; 4,665,759; 7,722,821 and pending applications.

© SpectroMicro and Chemplex are registered trademarks of Chemplex Industries, Inc.

™ FunnelShape is a trademark of Chemplex Industries, Inc.

**XRF THIN-FILM WINDOW TECHNICAL INFORMATION**  
**SPECTROCERTIFIED® THIN-FILM SAMPLE SUPPORT**  
**WINDOW MATERIALS**

- Sample Cups and Accessories
- Thin-Film Sample Supports**
- Grinding Machines and Accessories
- Briquetting Presses and Accessories
- Grinding/Briquetting Additives
- Fusion Machines and Accessories
- Standards and XRF/XRD Chemical Kits



A thin-film sample support window is a substance used for retaining liquid, powdered, slurry or solid specimens in XRF Sample Cups. Of the many different types of materials available, few possess the necessary combination of consistency and chemical and physical properties to serve x-ray spectrochemical needs.

**Typical Thickness Variations**

Variations	Uniformity of Thickness	Orientation
Between packages	< 1 – 2 %	Multiaxially orientated; minimizes effects of preferred orientation
Between lots	≤ ± 5%	

**Physical Characteristics**

Thin-Film Sample Support Substance	Melting Point, °C, °F	Density, gm/cc	Structural Formula
Etnom®	270 (518)	1.36	C <sub>14</sub> H <sub>10</sub> O <sub>4</sub>
Prolene®	165 (329)	0.91	C <sub>14</sub> H <sub>10</sub> P <sub>2</sub>
Mylar®	260 (500)	1.38	C <sub>14</sub> H <sub>10</sub> O <sub>4</sub>
Polypropylene	160 (320)	0.91	C <sub>3</sub> H <sub>4</sub>
Ultra-Polyester®	210 (410)	0.93	C <sub>14</sub> H <sub>10</sub> O <sub>4</sub>
Polyimide (Kapton®)	None reported	1.42	C <sub>20</sub> H <sub>10</sub> O <sub>2</sub> N <sub>2</sub>
Polycarbonate	267 (513)	1.37	C <sub>2</sub> H <sub>3</sub> F

**Purity**

Thin-Film Window Substance	Trace Impurities, PPM
Mylar®, Ultra-Polyester®	Ca, P, Sb, Fe, Zn
Prolene®, Polypropylene	Ca, P, Fe, Cu, Zr, Ti, Al
Etnom®	Si, Ca, P, Zn, Sb
Polyimide (Kapton®)	Unknown
Polycarbonate	Unknown

**CAUTION:** All thin-film window materials affixed to sample cups present the risk of stretching or rupturing in the sample chamber and/or causing sample cup leakage through the ring and cell juncture or disassembly with potential contamination and damage to the system. Additionally, the possibility of pinholes, pores and depressions existing in any thin-film sample support substance regardless of form, configuration and packaging can present leakage of a sample with subsequent contamination, costly clean-ups and damage to the analytical instrumentation and its components.

Chemplex Industries, Inc. is not the manufacturer of any thin-film substance and assumes no responsibility of the product substance as provided. It is strongly recommended that the products used be subject to judicious testing, use and applications and user evaluation prior to actual use by a method that does not risk contamination, costly clean-ups or damage to the x-ray analytical spectrometer. The responsibility of product purchase, acceptance and performance resides totally with the user. Chemplex Industries, Inc. assumes no liability or guarantees whatsoever that the products will perform in accordance with their usage, advertisements or methodologies written, orally expressed or insinuated.

© SpectroCertified, Prolene, Ultra-Polyester, Etnom and Chemplex are registered trademarks of Chemplex Industries, Inc.

® Mylar and Kapton are registered trademarks of E.I. DuPont de Nemours Inc.

## HOW TO SELECT AN XRF THIN-FILM SAMPLE SUPPORT WINDOW

Sample Cups  
and Accessories

Thin-Film  
Sample Supports

Grinding Machines  
and Accessories

Briquetting Presses  
and Accessories

Grinding/Briquetting  
Additives

Fusion Machines  
and Accessories

Standards and  
XRF/XRD Chemical Kits



Selection of a suitable thin-film sample support window is mostly based on satisfying primary important laboratory requirements:

- Convenience of use
- Contamination avoidance
- Chemical resistance to samples
- Analyte-line transmittance and intensity

The information presented entails the main packaging forms thin-films are offered, the various types of thin-films, a methodology for evaluating an appropriate thin-film for maximizing analyte-line percent transmittance and the resistance to sample chemical attack. Other issues of laboratory concern may include sample weight retention strength, performance under differential pressure conditions, integration time, excitation potential and related heat generation.

### DEPRESSIONS AND PINHOLES IN THIN-FILM SUBSTANCES

The potential possibility of depressions or pinholes may exist in a thin-film substance. A depression is not necessarily a pinhole. However, it presents a weak area in the thin-film substance that may chemically or physically develop into a pinhole and cause sample leakage. Chemplex Industries, Inc. does not manufacture the thin-film and assumes no liability whatsoever. With this understanding, the user assumes full responsibility for the purchase and usage of thin-film products and is advised to judiciously test each item for acceptability prior to use.

#### 1. CONVENIENCE OF USE AND CONTAMINATION AVOIDANCE

Dispensing and handling a thin-film in attempting to prepare a sample cup with a sample support window is frustrating, inconvenient and a source for contamination. This is attributed to the static electrical charges inherent to the thin-films that create static cling. The thin-film tends to stick to any surrounding object and one's person. This phenomenon presents the potential of contaminating the thin-film and affecting analytical x-ray data.

With the advent of SpectroMembrane® Sample Support Carrier Frames, there is no annoying static cling or potential contamination risk to the thin-film through handling or attraction of airborne particles. With the exception of the sample cup, the thin-film is never in intimate contact with anything else. Thin-film handling is performed by the use of the integrated carrier frames that automatically detach during the assembly process leaving taut thin-film sample planes.

- Sample Cups and Accessories
- Thin-Film Sample Supports**
- Grinding Machines and Accessories
- Briquetting Presses and Accessories
- Grinding/Briquetting Additives
- Fusion Machines and Accessories
- Standards and XRF/XRD Chemical Kits

**2. TRANSMITTANCE OF SPECTRAL LINES**

The transmittance properties of a thin-film are functions of gauge thickness, density and mass attenuation the following formula:  $I/I_0 = \exp[-(\mu/d)(d)]$

The following graphic representation of the above formula is the most frequently used visual aid in comparing % Transmittance values of various thin-film substances and gauges. Simply refer the spectral line of the element in the sample of analytical interest having the lowest energy, KeV, (or shortest wavelength, Angstrom, Å) to each of the curves representing thin-film materials and gauges. Compare their transmittance percentages and select the thin-film offering the highest % Transmittance value.

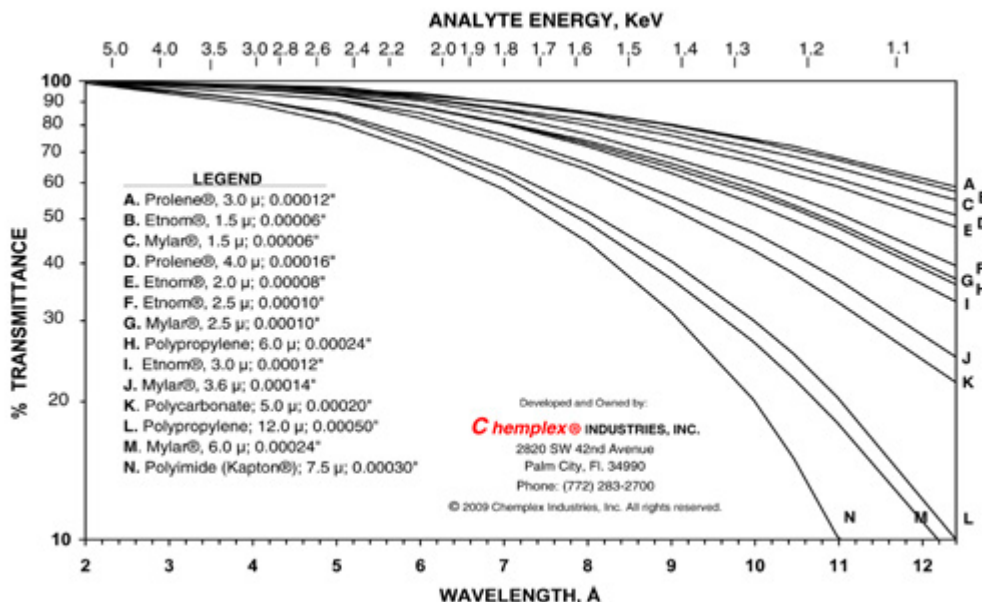

**RESISTANCE OF THIN-FILM SUBSTANCES TO CHEMICAL ATTACK**

CHEMICAL SAMPLE	POLYESTER (MYLAR®)	POLYCARBONATE	ETNOM®	POLYPROPYLENE	POLYIMIDE (KAPTON®)	PROLENE®	ULTRA-POLYESTER®
Acid, dilute or weak	G	G	G	E	N	G	G
Acids, conc.	G	G	G	E	N	E	G
Alcohols, aliphatic	N	G	G	E	G	E	N
Aldehydes	U	F	F	E	E	E	U
Alkalies, conc.	N	N	G	E	E	E	N
Esters	N	N	F	G	G	G	N
Ethers	F	N	F	N	U	N	F
Aliphatic Hydrocarbon	G	N	E	G	E	G	G
Aromatic Hydrocarbon	N	N	E	N	E	N	N
Halogenated Hydrocarbon	F	N	F	N	F	N	F
Ketones	N	N	G	G	G	G	N
Oxidizing agents	F	N	F	F	N	F	F

**E=Excellent, G=Good, F=Fair, N=Not recommended, U=Unknown**

**IMPORTANT:** The chemical resistances of thin-films contained in the above table are provided as a matter of information purpose only and they are not intended to preclude actual testing and suitability of use and applications. The responsibility of acceptance and safety resides totally with the user.

© Chemplex, Prolene, Ultra-Polyester and Etnom are registered trademarks of Chemplex Industries, Inc.

© Mylar and Kapton are registered trademarks of E.I. DuPont de Nemours & Co., Inc

**IMPORTANT:** Some window materials may not be suitable for analyzing sulfur in diesel fuel, gasoline and other petroleum products containing aromatic hydrocarbons. ASTM D-6445-99 (Reapproved 2004) e1: "Samples of high aromatic content may dissolve polyester and polycarbonate films. In these cases, other materials besides these films may be used for X-ray windows, provided that they do not contain any elemental impurities. An optional window material is polyimide film. While polyimide film absorbs sulfur x-rays more than other films, it may be a preferred window material as it is much more resistant to chemical attack by aromatics and exhibits higher mechanical strength." ASTM D 4294-08a: "Any film that resists attack by the sample, is free of sulfur, and is sufficiently X-ray transparent can be used. Film types can include polyester, polypropylene, polycarbonate, and polyimide. However, samples of high aromatic content can dissolve polypropylene, polycarbonate and polyester." Chemplex Industries, Inc., assumes no liability whatsoever in the purchase and use of any thin-film sample support window film regardless of configuration, suggested uses and applications, claims, reports, exhibits, advertised or written or orally expressed or insinuated. Judicious testing and evaluation is strongly recommended before purchase, use and acceptance of these products.

- Sample Cups and Accessories
- Thin-Film Sample Supports**
- Grinding Machines and Accessories
- Briquetting Presses and Accessories
- Grinding/Briquetting Additives
- Fusion Machines and Accessories
- Standards and XRF/XRD Chemical Kits

**XRF SAMPLE CUP THIN-FILM WINDOW CHEMICAL RESISTANCE TEST & LEAK DETECTOR PAPER**



The need for a convenient method to determine the chemical resistance of a thin-film sample support material from exposure to different liquid sample substances before analysis prompted the development of Chemical Resistance Test Paper. Used in conjunction with referral to the listed [“Chemical Resistance Chart”](#) to sample substances expressed as chemical classification in the Thin-Film Section, Chemical Resistance Test Paper offers the analyst a secondary method to avoid thin-film sample support chemical degradation and potential damage to the instrumentation in advance. This becomes particularly important in planning to analyze samples of unknown chemical composition and inability to relate to a chemical classification listing.

The methodology is based on observing the formation of a stain on a specially processed colored paper. A test sample cup is prepared with the intended thin-film sample support and filled with a subject liquid sample substance. The assembled test sample cup is placed on a Chemical Resistance Test Paper Circle for a given length of time generally greater than the integration time of analysis. The existence of a stain indicates that there has been penetration of a sample substance through a considered thin-film sample support material. The absence of a stain insinuates acceptability of use.

It must be noted that chemical attack of the thin-film may be time related. In addition, chemical attack may assume different forms such as softening and sagging of the thin-film, creation and enlargement of minute pinholes, initial occurrence at the weakest points of contact of the thin-film stretched around the sample cup edge and intent to use at atmospheric pressure, pressured or evacuated optical environment and x-ray excitation temperature. Clear, volatile and aqueous liquids tend to evaporate quickly and present difficulty in observing staining.

**Typical Applications**

Mineral Oil Diesel Fuel Synthetic Diesel Fuel Residual Oil Waste Oil Lubricating Oil Gasoline Organo Metallic Oil Crude Oil Light Oil Biofuels Synlubes Metal Working Fluids Motor Oil Lubricants Kerosene Iso-octane And many other petrochemical liquids formulated with Aliphatic Hydrocarbons and specifically with Aromatic Hydrocarbons

Cat. No.	Description	Diameter	Number of Circles/Pkg
6150	Thin-Film Window Chemical Resistance Test Paper	2-1/2" (63.5mm)	500

## SpectroMembrane<sup>®</sup> XRF Thin-Film Sample Support Window Carrier Frames

Sample Cups and Accessories

Thin-Film Sample Supports

Grinding Machines and Accessories

Briquetting Presses and Accessories

Grinding/Briquetting Additives

Fusion Machines and Accessories

Standards and XRF/XRD Chemical Kits



SpectroMembrane<sup>®</sup> Thin-Film Sample Support Carrier Frames consist of a thin-film sample support substance attached to a frame that serves as a carrier. In affixing a thin-film substance to an XRF Sample Cup, the thin-film material is not directly handled and a contamination possibility is completely eliminated. Nearing or at the completion of attachment, the thin-film automatically detaches from the carrier frame leaving a taut wrinkle-free sample support window.

# NO

**WASTE  
STATIC CLING  
CONTAMINATION  
EXPERIENCE NECESSARY**

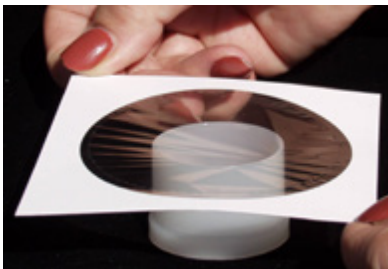

**Step 1.**  
Place SpectroMembrane<sup>®</sup> Carrier Frame Over XRF Sample Cup

**Step 2.**  
Press Snap-On Ring or Sleeve over SpectroMembrane<sup>®</sup> Carrier Frame and tear away Carrier Frame



**SpectroMembrane<sup>®</sup> Thin-Film Carrier Frames are packaged 100 units per package to match the same packaging as 100 XRF Sample Cup Sets per package. When ordering packages of XRF Sample Cups, simply order the same number of SpectroMembrane<sup>®</sup> Thin-Film Carrier Frame packages.**

**SpectroMembrane® XRF Thin-Film Sample Support  
Window Carrier Frames  
SPECIFICATIONS AND ORDERING INFORMATION**

CAT. NO.	THIN-FILM SUBSTANCE	GAUGE (Thickness)	CIRCLE DIAMETER	SUGGESTED CHEMPLEX XRF SAMPLE CUP CATALOG USE	
3011	Mylar®	2.5 µ; 0.00010"; 0.10 mil; 0.00254 mm	2.5" (63.5mm)	1060, 1065, 1330,1430, 1530, 1730, 1830, 1930, 2132 and 3100 Series	
3012		2.5 µ; 0.00010"; 0.10 mil; 0.00254 mm	3.0" (76.2mm)	1070,1075,1080,1085,1095,1340,1440,1440L,1540, 1740, 1840, 1850, 1940, 2135, 2140, 2143, 2145, 2146,2195	
3013		3.6 µ; 0.00014"; 0.14 mil; 0.00356 mm	2.5" (63.5mm)	1060, 1065, 1330,1430, 1530, 1730, 1830, 1930, 2132 and 3100 Series	
3014		3.6 µ; 0.00014"; 0.14 mil; 0.00356 mm	3.0" (76.2mm)	1070,1075,1080,1085,1095,1340,1440,1440L,1540, 1740, 1840, 1850, 1940, 2135, 2140, 2143, 2145, 2146,2195	
3015		6.0 µ; 0.00024"; 0.24 mil; 0.00610 mm	2.5" (63.5mm)	1060, 1065, 1330,1430, 1530, 1730, 1830, 1930, 2132 and 3100 Series	
3016		6.0 µ; 0.00024"; 0.24 mil; 0.00610 mm	3.0" (76.2mm)	1070,1075,1080,1085,1095,1340,1440,1440L,1540, 1740, 1840, 1850, 1940, 2135, 2140, 2143, 2145, 2146,2195	
3017		Prolene®	4.0 µ; 0.00016"; 0.16 mil; 0.00406 mm	2.5" (63.5mm)	1060, 1065, 1330,1430, 1530, 1730, 1830, 1930, 2132 and 3100 Series
3017A			3.0 µ; 0.00012"; 0.12mil; 0.00305 mm		
3018			4.0 µ; 0.00016"; 0.16 mil; 0.00406 mm	3.0" (76.2mm)	1070,1075,1080,1085,1095,1340,1440,1440L,1540, 1740, 1840, 1850, 1940, 2135, 2140, 2143, 2145,2146, 2195
3018A			3.0 µ; 0.00012"; 0.12mil; 0.00305 mm		
3019	Polypropylene	6.0 µ; 0.00024"; 0.24 mil; 0.00610 mm	2.5" (63.5mm)	1060, 1065, 1330,1430, 1530, 1730, 1830, 1930, 2132 and 3100 Series	
3020		6.0 µ; 0.00024"; 0.24 mil; 0.00610 mm	3.0" (76.2mm)	1070,1075,1080,1085,1095,1340,1440,1440L,1540, 1740, 1840, 1850, 1940, 2135, 2140, 2143, 2145, 2146, 2195	
3023	Polypropylene	12.0 µ; 0.00050"; 0.50 mil; 0.0127 mm	2.5" (63.5mm)	1060, 1065, 1330,1430, 1530, 1730, 1830, 1930, 2132 and 3100 Series	
3024		12.0 µ; 0.00050"; 0.50 mil; 0.0127 mm	3.0" (76.2mm)	1070,1075,1080,1085,1095,1340,1440,1440L,1540, 1740, 1840, 1850, 1940, 2135, 2140, 2143, 2145, 2146,2195	
3025	Etnom®  (Resistant to Aliphatic and Aromatic Hydrocarbons)	3.0 µ; 0.00012"; 0.12mil; 0.00305 mm	2.5" (63.5mm)	1060, 1065, 1330,1430, 1530, 1730, 1830, 1930, 2132 and 3100 Series	
3026		3.0 µ; 0.00012"; 0.12mil; 0.00305 mm	3.0" (76.2mm)	1070,1075,1080,1085,1095,1340,1440,1440L,1540, 1740, 1840, 1850, 1940, 2135, 2140, 2143, 2145, 2146,2195	
3029		2.5µ; 0.00010; 0.10mil; 0.00254 mm	2.5" (63.5mm)	1060, 1065, 1330,1430, 1530, 1730, 1830, 1930, 2132 and 3100 Series	
3030		2.5 µ; 0.00010"; 0.10mil; 0.00254 mm	3.0" (76.2mm)	1070,1075,1080,1085,1095,1340,1440,1440L,1540, 1740, 1840, 1850, 1940, 2135, 2140, 2143, 2145, 2146,2195	
3031	3032	2.0 µ; 0.00008"; 0.08mil; 0.00203 mm	2.5" (63.5mm)	1060, 1065, 1330,1430, 1530, 1730, 1830, 1930, 2132 and 3100 Series	
3032		2.0 µ; 0.00008"; 0.08mil; 0.00203 mm	3.0" (76.2mm)	1070,1075,1080,1085,1095,1340,1440,1440L,1540, 1740, 1840, 1850, 1940, 2135, 2140, 2143, 2145, 2146,2195	
3090	Ultra-Polyester®	1.5 µ; 0.00006"; 0.06mil; 0.00152 mm	3.0" (76.2mm)	1060, 1065, 1330,1430, 1530, 1730, 1830, 1930, 2132 and 3100 Series	

Reg. US Patent No: 6,009,766 and other patents in applications

© Prolene, Etnom, SpectroMembrane, Ultra-Polyester and Chemplex are registered trademarks of Chemplex Industries, Inc.

© Mylar is a registered trademarks of E.I. DuPont de Nemours, Inc.

IMPORTANT: Some window materials may not be suitable for analyzing sulfur in diesel fuel, gasoline and other petroleum products containing aromatic hydrocarbons. ASTM D-6445-99 (Reapproved 2004) e1: "Samples of high aromatic content may dissolve polyester and polycarbonate films. In these cases, other materials besides these films may be used for X-ray windows, provided that they do not contain any elemental impurities. An optional window material is polyimide film. While polyimide film absorbs sulfur x-rays more than other films, it may be a preferred window material as it is much more resistant to chemical attack by aromatics and exhibits higher mechanical strength." ASTM D 4294-08a: "Any film that resists attack by the sample, is free of sulfur, and is sufficiently X-ray transparent can be used. Film types can include polyester, polypropylene, polycarbonate, and polyimide. However, samples of high aromatic content can dissolve polypropylene, polycarbonate and polyester."

- Sample Cups and Accessories
- Thin-Film Sample Supports**
- Grinding Machines and Accessories
- Briquetting Presses and Accessories
- Grinding/Briquetting Additives
- Fusion Machines and Accessories
- Standards and XRF/XRD Chemical Kits

**SpectroCertified® XRF Thin-Film Windows**  
Continuous Rolls, Pre-Perforated Rolls and Precut Circles



use by simply detaching a 3" section from the bulk roll at the perforations.

Thin-Film Sample Support Windows are available in Continuous Rolls, Pre-Perforated Rolls and Pre-Cut Circles interleaved with lint-free tissue carriers, in addition to SpectroMembrane® Thin-Film Carrier Frames. Fabrication and storage of all thin-films is performed under environmentally controlled conditions and immediately individually shrink-wrapped in clear plastic to preserve the original integrity. These extra precautionary measures are necessary to avoid the potential possibility of inadvertently introducing trace levels of contaminants that may affect x-ray data.

**Pre-Perforated Thin-Film Rolls**

XRF analysts interested in adding convenience to their usage of continuous thin-film window rolls and reducing waste, consider using Pre-Perforated Thin-Film Rolls. Simply detach three square inch sections from the bulk roll at the perforations as required. One 300' long x 3" wide roll serves to prepare 1200 thin-film windows without waste. Available with all thin-film roll catalog numbers ending in "PP."

**SPECIFICATIONS AND ORDERING INFORMATION**

**CONTINUOUS ROLLS:**

(3" wide x 300' long; 7.6cm x 91.4 m)

CATALOG NUMBER	THIN-FILM SUBSTANCE	GAUGE
090	Ultra-Polyester®	1.5 µ; 0.00006"; 0.06mil; 0.00152mm
095	Etnom®	1.5 µ; 0.00006"; 0.06mil; 0.00152mm
100	Mylar®	2.5 µ; 0.00010"; 0.10 mil; 0.00254mm
150	Mylar®	3.6 µ; 0.00014"; 0.14 mil; 0.00356mm
250	Mylar®	6.0 µ; 0.00024"; 0.24 mil; 0.00610mm
416	Prolene®	4.0 µ; 0.00016"; 0.16 mil; 0.00406mm
425	Polypropylene	6.0 µ; 0.00024"; 0.24 mil; 0.00610mm
475	Polypropylene	12.0 µ; 0.00050"; 0.50 mil; 0.0127mm

\*Supplied in 50' (15.2m) lengths

**PRE-PERFORATED THIN-FILM ROLLS:**

3" wide x 300' long (7.6cm x 91.4 m) roll; 1200 Individual 3" x 3" (7.6cm x 7.6 cm) Perforated Sheets

CATALOG NUMBER	THIN-FILM SUBSTANCE	GAUGE
090-PP	Ultra-Polyester®	1.5 µ; 0.00006"; 0.06mil; 0.00152mm
095-PP	Etnom®	1.5 µ; 0.00006"; 0.06mil; 0.00152mm
100-PP	Mylar®	2.5 µ; 0.00010"; 0.10 mil; 0.00254mm
150-PP	Mylar®	3.6 µ; 0.00014"; 0.14 mil; 0.00356mm
250-PP	Mylar®	6.0 µ; 0.00024"; 0.24 mil; 0.00610mm
416-PP	Prolene®	4.0 µ; 0.00016"; 0.16 mil; 0.00406mm
425-PP	Polypropylene	6.0 µ; 0.00024"; 0.24 mil; 0.00610mm
475-PP	Polypropylene	12.0 µ; 0.00050"; 0.50 mil; 0.0127mm

**SpectroCertified® XRF Thin-Film Windows**  
Continuous Rolls, Pre-Perforated Rolls and Precut Circles



- Sample Cups and Accessories
- Thin-Film Sample Supports**
- Grinding Machines and Accessories
- Briquetting Presses and Accessories
- Grinding/Briquetting Additives
- Fusion Machines and Accessories
- Standards and XRF/XRD Chemical Kits

**PRECUT CIRCLES: (500 pieces/box)**  
(2.5" Diameter; 63.5mm)

CATALOG NUMBER	THIN-FILM SUBSTANCE	GAUGE
106	Mylar®	2.5 µ; 0.00010"; 0.10 mil; 0.00254mm
156	Mylar®	3.6 µ; 0.00014"; 0.14 mil; 0.00356mm
256	Mylar®	6.0 µ; 0.00024"; 0.24 mil; 0.00610mm
426	Prolene®	4.0 µ; 0.00016"; 0.16 mil; 0.00406mm
436	Polypropylene	6.0 µ; 0.00024"; 0.24 mil; 0.00610mm
476	Polypropylene	12.0 µ; 0.00050"; 0.50 mil; 0.0127mm

**PRECUT CIRCLES: (1000 pieces/box)**  
(2.5" Diameter; 63.5mm)

CATALOG NUMBER	THIN-FILM SUBSTANCE	GAUGE
107	Mylar®	2.5 µ; 0.00010"; 0.10 mil; 0.00254mm
157	Mylar®	3.6 µ; 0.00014"; 0.14 mil; 0.00356mm
257	Mylar®	6.0 µ; 0.00024"; 0.24 mil; 0.00610mm
427	Prolene®	4.0 µ; 0.00016"; 0.16 mil; 0.00406mm
437	Polypropylene	6.0 µ; 0.00024"; 0.24 mil; 0.00610mm
477	Polypropylene	12.0 µ; 0.00050"; 0.50 mil; 0.0127mm

**IMPORTANT:** Some window materials may not be suitable for analyzing sulfur in diesel fuel, gasoline and other petroleum products containing aromatic hydrocarbons. ASTM D-6445-99 (Re-approved 2004) e1: **“Samples of high aromatic content may dissolve polyester and polycarbonate films.** In these cases, other materials besides these films may be used for X-ray windows, provided that they do not contain any elemental impurities. An optional window material is polyimide film. While polyimide film absorbs sulfur x-rays more than other films, it may be a preferred window material as it is much more resistant to chemical attack by aromatics and exhibits higher mechanical strength.” ASTM D 4294-08a: “Any film that resists attack by the sample, is free of sulfur, and is sufficiently X-ray transparent can be used. Film types can include polyester, polypropylene, polycarbonate, and polyimide. **However, samples of high aromatic content can dissolve polypropylene, polycarbonate and polyester.”**

**CAUTION:** All thin-film window materials affixed to sample cups present the risk of stretching or rupturing in the sample chamber and/or causing sample cup leakage through the ring and cell juncture or disassembly with potential contamination and damage to the system. These conditions are especially amplified when the sample chamber is subjected to a change in pressure attributed to evacuation, introduction of an inert gas flush or from pressure build-up within the sample cup from a sample substance out gassing or from volatility. Additionally, the possibility of pinholes, pores and depressions existing in any thin-film sample support substance regardless of form, configuration and packaging can present leakage of a sample with subsequent contamination and damage to the analytical instrumentation and its components. It is strongly recommended that the products used be subject to judicious testing, use and applications and user evaluation prior to actual use by a method that does not risk contamination or damage to the x-ray analytical spectrometer. The responsibility of product acceptance and performance resides totally with the user. Chemplex Industries, Inc. assumes no liability or guarantees whatsoever that the products will perform in accordance with their usage, advertisements or methodologies written, orally expressed, implied or insinuated.

© Prolene, Etnom, SpectroMembrane, SpectroCertified, Ultra-Polyester and Chemplex are registered trademarks of Chemplex Industries, Inc.  
© Kapton and Mylar are registered trademarks of E.I. DuPont de Nemours, Inc.

- Sample Cups and Accessories
- Thin-Film Sample Supports**
- Grinding Machines and Accessories
- Briquetting Presses and Accessories
- Grinding/Briquetting Additives
- Fusion Machines and Accessories
- Standards and XRF/XRD Chemical Kits

**XRF Microporous Gas Permeable Polypropylene Film**  
**EQUALIZING PRESSURE DIFFERENTIAL FILM**

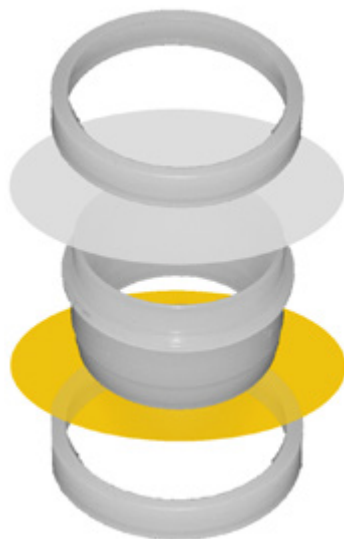

1500 Series XRF Sample Cup illustrated with optionally available [Microporous Film](#) for equalizing pressure differentials within the sample cup and sample chamber.

Microporous Film is a gas permeable membrane that enables the analysis of non-volatile liquid and powdered sample substances in helium flushes or vacuum. Pressure differentials within the sample cup and sample chamber are equalized while maintaining a taut thin-film sample support plane. The [Series 1500](#) XRF Sample Cups are designed for use with Microporous Film.

One of two supplied “Snap-On Rings” included with the 1500 Series Sample Cups is used to attach Microporous Film to the Cell neck at the open end of the sample cup nearest the outer integrated flange.

The sample cup Cell is designed with the unique “bead-to-indent” geometry that creates taut thin-film sample support planes and effective seals against leakage.

The second included “Snap-On Ring” is used to affix a thin-film sample support window to the opposite open end of the sample cup.

In practice, the illustrated assembly procedure is reversed. The thin-film sample support is attached first enabling one or more sample cups to be conveniently filled from the top end; Microporous Film is attached last.

Microporous Film is available in Continuous Rolls and convenient Pre-cut Circles. The Pre-cut Circles eliminate trimming and facilitate attachment to the 1500 Series XRF Sample Cups.

Properties	Typical Values
Porosity, %	55
Pore Size, $\mu \times \mu$	0.21 x 0.05
Thickness, $\mu$ (inches; mm)	25 (0.001"; 0.0254mm)
Softening Temperature, °C	Approx. 155
Melting Temperature, °C	Approx. 165

**SPECIFICATIONS AND ORDERING INFORMATION**

(Microporous Film in Continuous Rolls and Easy-to-Use Pre-Cut Circles)

Catalog Number	Description	Packaging
325*	Microporous Film, Continuous Roll	2.5" wide x 200" long (6.4cm x 5.1m)
325C	Microporous Film, Pre-Cut Circles	2.5" (76mm) diameter; 100 circles/Pkg

\*Supplied in unserrated metal edge boxes.

**Note: Microporous Film is promoted solely for pressure differential equalization purposes in x-ray spectroscopy.**

Sample Cups and Accessories
Thin-Film Sample Supports
Grinding Machines and Accessories
Briquetting Presses and Accessories
Grinding/Briquetting Additives
Fusion Machines and Accessories
Standards and XRF/XRD Chemical Kits

## XRF Liquid Sample Transfer Pipettes

### SIMPLIFY FILLING XRF SAMPLE CUPS GENERAL LABORATORY USE



Chemplex transfer pipettes are used to conveniently fill Chemplex XRF Sample Cups with equal volumes of samples and standards to their near volumetric capacities, minimize or eliminate any discrepancies in x-ray data attributed to dissimilar volumes, avoid spillage and prevent cross-contamination possibilities plus they are affordably priced for disposability.

#### How to Select the Most Appropriate XRF Sample Cup Transfer Pipette

Selection of the most appropriate transfer pipette is related to a match between the volumetric capacity of a sample cup and the dispensing volume of a pipette. For convenience of user selection, these correlations have been pre-determined, compiled and presented in the **“Pipette Selection Guide”** listed below. The **“Guide”** enables the selection of a pipette by first referring to the Chemplex sample cup that is currently or intended to be used and reading across the chart to the recommended pipette catalog number. Because of the large number of sample cup offering and different volumetric capacities, one or more sequential transfers of the same sample or standard from the same pipette, commonly referred to as “draws”, may be necessary. The number of draws required to fill a sample cup are indicated in the **“Guide.”**

#### Viscosity Considerations

The transfer of viscous substances such as petroleum, waste oils, paint and slurries is more expeditiously handled with large pipette tips. Most other materials with high fluidity characteristics are served best with pipettes having fine tips. Empirical testing is suggested for confirmation of convenience.

#### How to Use Transfer Pipettes

Transfer pipettes are fabricated from unbreakable polyethylene with the bulb integrated with the stem as a single unit; transfer pipettes are not sterile.

Squeeze the bulb of the pipette to expel the air and insert the tip into the sample. Release the applied hand pressure to the bulb until the sample is completely drawn up. Insert the tip of the filled pipette into the sample cup and gently squeeze the bulb to dispense the entire sample. Repeat the procedure in instances that require additional draws to fill the sample cup. The volume dispensed from a transfer pipette can vary with each transfer in accordance with operator manipulation of the bulb.

#### Disposability

Transfer pipettes are intended to be used once, excepting for multiple sequential draws, to avert cross-contamination possibilities. Dispose used pipettes properly in accordance with local and other accepted procedures.

- IDEAL FOR FILLING XRF SAMPLE CUPS**
- ENSURE EQUAL SAMPLE VOLUMES PER CUP**
- AVOID ACCIDENTAL SPILLAGE**
- PREVENT CROSS-CONTAMINATION**
- INTEGRATED BULB FOR CONVENIENCE**
- UNBREAKABLE POLYETHYLENE**
- ECONOMICALLY PRICED FOR ONE TIME USE**

### Pipette Selection Guide for XRF Use

Sample Cup and Accessories	Sample Cup Cat. No.	Pipette Cat. No.	Capacity, mL	Number Draws	Sample Cup Cat. No.	Pipette Cat. No.	Capacity mL	Number Draws
Thin-Film Sample Supports	1060	80-0204 80-0234	9	2	1730,1730-SE	80-0252 80-0204	7	1
Grinding Machines and Accessories	1065	80-0691 80-0252 80-0204	8	1	1740	80-0234 80-0691 80-0252	11.5	3
Briquetting Presses and Accessories	1070	80-0234 80-0691 80-0204	13	3	1830,1830-SE	80-0252 80-0204	7	1
Grinding/Briquetting Additives	1075	80-0234 80-0691 80-0204	13	3	1840	80-0234 80-0691 80-0204	12	3
Fusion Machines and Accessories	1080	80-0252 80-0204	15	2	1850	80-0234 80-0691 80-0204	13	3
Standards and XRF/XRD Chemical Kits	1083	80-0234 80-0691 80-0204	12	3	1930,1930-SE	80-0252 80-0252	8	1
	1085	80-0234 80-0691 80-0204	12	3	1940	80-0252	15	2
	1095	80-0252	30	4	1940L	80-0252	25	3
	1330,1330-SE	80-0252	7	1	1935-OX	80-0252 80-0204	17	2
	1340	80-0204 80-0234 80-0691 80-0204	12	3	2132	80-0234 80-0691 80-0204	9	2
	1430,1430-SE	80-0234 80-0691	9	2	2135	80-0234 80-0691	11	3
	1440	80-0252	15	2	2140	80-0252	19	3
	1440L	80-0252	25	3	2143	80-0252	19	3
	1530,1530-SE	80-0234 80-0691	9.5	2	2144	80-0252	19	3
	1540	80-0252	16	2	2145	80-0252	22	3
					2146	80-0252	22	3
					2195	80-0252	22	3
					3106	80-0225	0.2	1
					3110	80-0225	0.5	1
					3115	80-0225	1	1
					3120	80-0225	5.5	2

**Note:** The volume dispensed from a transfer pipette can vary in accordance with operator manipulation of the bulb.

#### General Laboratory Use

For general laboratory applications, transfer pipettes find their greatest utility in transferring innumerable types of liquid chemicals into other lab ware. With Chemplex transfer pipettes this procedure is greatly simplified and performed with ease, reasonable degrees of accuracy, safety, no contamination and economically priced for disposability.

The following table will provide the analyst with pertinent technical information on the specifics of each of the transfer pipettes.

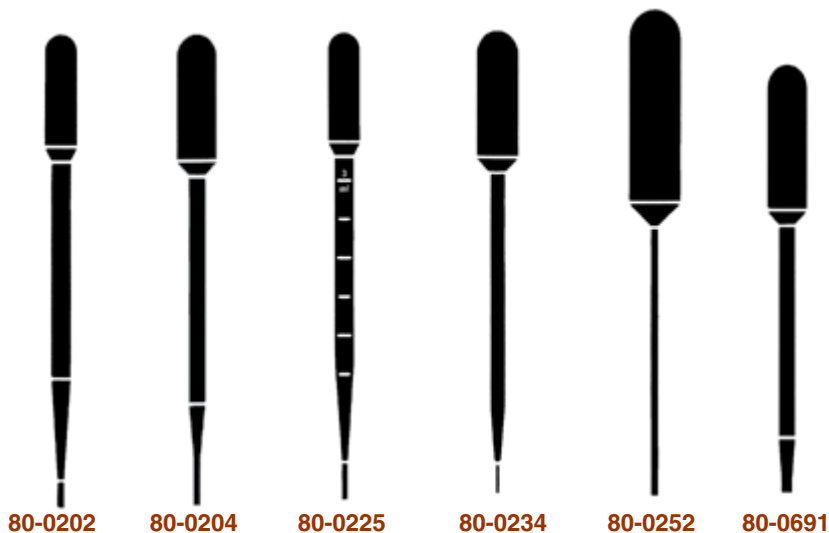

- Sample Cups and Accessories
- Thin-Film Sample Supports
- Grinding Machines and Accessories
- Briquetting Presses and Accessories
- Grinding/Briquetting Additives
- Fusion Machines and Accessories
- Standards and XRF/XRD Chemical Kits

**Additional Pipette Specifications for General Laboratory Use**



**Specifications and Ordering Information**

Pipette Cat. No.	Description	Length cm	Stem Dia. mm	Overall Capacity mL	Bulb Draw mL	Drops per mL
80-0202	General purpose; standard	15.6	7.9	7.7	3.2	20
80-0204	General purpose; large bulb	15.1	6.1	8.0	4.6	20
80-0225	Graduated 3mL; large bulb	15.5	7.9	7.5	3.2	20
80-0234	Fine tip; large bulb	14.7	6.1	8.7	4.8	45
80-0252	Large bulb	15.5	3.0	15.0	8.0	19
80-0691	62 µ Liter; large aperture	13.7	6.1	9.3	4.8	----

**Specifications and Ordering Information**

Cat. No.	Description	Pipettes/Pkg	Pkgs/Case
80-0202	General purpose; standard; 15.6 cm long	500	10
80-0204	General purpose; medium tip; large bulb; 15.1 cm long	400	10
80-0225	Graduated, 3mL; large bulb; 15.5 cm long	500	10
80-0234	Fine tip; large bulb; 14.7 cm long	400	10
80-0252	Medium tip; narrow stem; large bulb; 15.5 cm long	250	10
80-0691	Large tip; 13.7 cm long	250	10

**Note:** Transfer pipettes are non-sterile and sold only in complete packages. As a reminder for XRF applications, be certain to order the number of pipettes to correspond to the number of sample cups to be filled; Chemplex XRF Sample Cups are packaged in quantities of 100 sets.

## XRF Sample Cup Assembly and Filling Work Stations

Sample Cups  
and Accessories

Thin-Film  
Sample Supports

Grinding Machines  
and Accessories

Briquetting Presses  
and Accessories

Grinding/Briquetting  
Additives

Fusion Machines  
and Accessories

Standards and  
XRF/XRD Chemical Kits



Single Position Work Station for Single Position X-Ray



Retains Six of Same or Dissimilar Diameter Sample



White Imprinted Numbered Work

Chemplex XRF Sample Cup Work Stations provide the analyst with an orderly means for handling sample cups after affixing thin-film sample support windows, preventing contamination of the thin-film by eliminating contact with a counter top surface and facilitating sample cup filling procedures with [Transfer Pipettes](#).

A work station consists of one or six individual conical shaped concavities that allow acceptance of any size sample cups of the same or dissimilar diameters ranging from 24 mm to 45 mm. The conical shape of the cavity allows the smaller diameter sample cups to rest lower into the cavity than the larger sample cup diameters while maintaining the sample cups level in position. Multi-cavity work stations allow for the advanced preparation of a large number of samples in readiness for transporting to the instrumentation for x-ray analysis and a means for storage for future referral.

### Model 1360 XRF Single Sample Cup Work Station

This single position cavity work station is 3" (76 mm) in diameter and will accept any sample cup within 24 to 45 mm in diameter. The small compact size work station is suitable for instruments designed for single sample accommodation with adequate time in between analysis for preparing additional samples.

### Model 1370 Multiple XRF Sample Cup Work Station

This multi-cavity work station is 3" wide x 12.5" long (7.6 cm x 31.65 cm) and will accept any combination of different sample cups within 24 to 45 mm in diameter. There are six cavities in a single row with sequential numbers stamped in white adjacent to each cavity for identification purposes. Ideally suitable for use with instruments that accommodate multiple samples and for laboratories equipped with additional instruments that may be assigned their own work stations for convenience and to avoid potential inadvertent confusions.

Catalog Number	Description	Number of Units per Package
1360	Single XRF Sample Cup Work Station	4
1370	Six Cavity XRF Sample Cup Work Station	2

## SpectroFilm® Self-Sticking Safety XRF Secondary Film

Sample Cups and Accessories
Thin-Film Sample Supports
Grinding Machines and Accessories
Briquetting Presses and Accessories
Grinding/Briquetting Additives
Fusion Machines and Accessories
Standards and XRF/XRD Chemical Kits

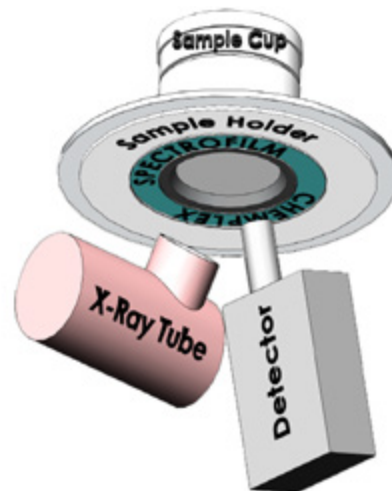
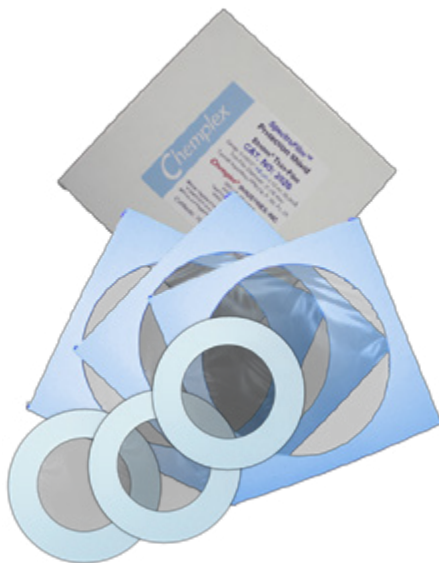

Self-Sticking Backing Secures SpectroFilm® Safety Film for attachment to the sample holder stage.

SpectroFilm® offers the analyst a practical means to protect the x-ray tube and detector windows and related electronics from exposure to accidental sample material spillage. This is easily accomplished by affixing a self-sticking SpectroFilm® Safety Secondary Window between the stage separating the lower electronics compartment and upper sample chamber.

### AVERT

- Costly damage to x-ray tube windows
- Costly damage to x-ray detector windows
- Costly damage to electronics
- Costly contamination issues
- Costly cleanups

#### Description

A SpectroFilm® Self-Sticking Safety Secondary Window consists of a thin-film substance pre-affixed to a paper blue paper frame with a central aperture and an adhesive backing on the obverse side.

Adhesive is protected with a removable release paper to expose the adhesive in readiness for attachment covering the opening in the platform intended to maintain separation between the sample holder and electronics chambers. Sample spillages are collected on the thin-film substance.

For ease of identification, the obverse side of the SpectroFilm® is dark blue and the reverse side is lighter in color attributed to the translucence of the white release paper. SpectroFilm® is available with square or round paper frames of user choice. Removal of the release paper exposes the adhesive to secure the SpectroFilm® Safety Film in position.

#### Thin-Film Materials Available

SpectroFilm® is available in several different thin-film substances that offer a broad range of chemical resistance to sample spillages: Mylar®, Prolene® and especially Etnom®, which is noted for its exceptional resistance to both aliphatic and aromatic hydrocarbons. SpectroFilm® Safety Film is available in three similar thin-film gauges of similar percent transmittance values and tensile sample retention strengths.

#### Easy-to-Use

Prepare the location where the SpectroFilm® is to be applied by cleaning and removing any residual oil or particles to provide a good bonding surface. Remove the release paper to expose the adhesive layer surface. Center the SpectroFilm® with the adhesive surface faced down directly over the aperture in the platform separating the sample holder and electronics compartments. Firmly press down the paper frame edges to ensure a complete and effective protective thin-film shield. Replace the SpectroFilm® Safety Secondary Film periodically to avoid the thin-film from becoming brittle after extended usage rendering it potentially ineffective. Thoroughly absorb, clean and dry any residual spillages and the surface separating the platform prior to re-applying a new SpectroFilm® Safety Film.

#### Square SpectroFilm® Safety Secondary Window Frame Holders:

Cat. No.	Description	Dimensions	Number of Units/Pkg
2014	3.6 µ Mylar® SpectroFilm® Safety Window	Frame: 99mm x 99mm Outside Thin-Film Window: 83 mm Diameter	75
2018	3.0 µ Prolene® SpectroFilm® Safety Window		
2026	3.0 µ Etnom® SpectroFilm® Safety Window		

#### Circular SpectroFilm® Safety Secondary Window Frame Holders:

Cat. No.	Description	Dimensions	Number of Units/Pkg
2042R6M3.6	3.6 µ Mylar® SpectroFilm® Safety Window	Frame: 60 mm Diameter Thin-Film Window: 42mm Diameter	25
2042R6P3.0	3.0 µ Prolene® SpectroFilm® Safety Window		
2042R6E3.0	3.0 µ Etnom® SpectroFilm® Safety Window		

NOTE: For effective seals the platform must be thoroughly cleaned and free of any oily substances, residual particles and other materials that may impair adhesion of the SpectroFilm.

\* Patent Pending

© Prolene, SpectroFilm, Etnom and Chemplex are registered trademarks of Chemplex Industries, Inc; all rights reserved.

© Mylar is a registered trademark of E.I. DuPont de Nemours & Co.

Sample Cups  
and Accessories

Thin-Film  
Sample Supports

Grinding Machines  
and Accessories

Briquetting Presses  
and Accessories

Grinding/Briquetting  
Additives

Fusion Machines  
and Accessories

Standards and  
XRF/XRD Chemical Kits

## XRF Sample Cup “Snap-On Ring” Fastener

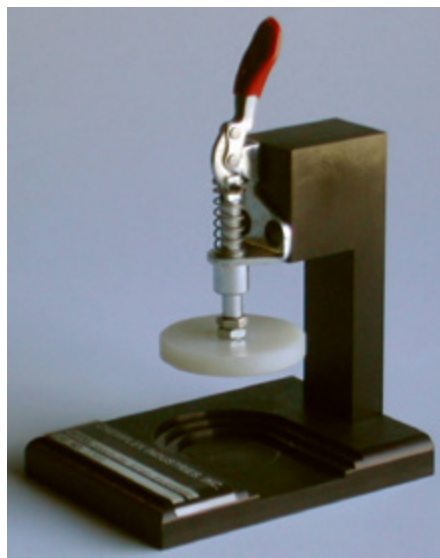

This unique device is designed to facilitate the attachment of thin-film sample support windows to sample cups utilizing “Snap-On Rings.” Averts contamination by contact during assembly, allows uniform application of pressure, eliminates Snap-On Ring misalignment and ensures taut thin-film sample support planes; ideally suitable for multiple sample preparations.



### SIMPLE, FAST AND CONVENIENT TO USE

1. Insert sample cup on platform
2. Cover sample cup opening with thin-film
3. Position “Snap-On Ring” over thin-film
4. Depress lever and release



### USABLE WITH THE FOLLOWING XRF SAMPLE CUPS

SAMPLE CUP CAT. NO.	SAMPLE CUP CAT. NO.
1330	1730 SE
1330 SE	1740
1430	1830
1430 SE	1830 SE
1440	1840
1530	1930
1530 SE	1930 SE
1540	1940
1730	1850

### SPECIFICATIONS AND ORDERING INFORMATION

CATALOG NUMBER	DESCRIPTION
1300	Snap-On Ring Fastener

- Sample Cups and Accessories
- Thin-Film Sample Supports
- Grinding Machines and Accessories
- Briquetting Presses and Accessories
- Grinding/Briquetting Additives
- Fusion Machines and Accessories
- Standards and XRF/XRD Chemical Kits

## XRF Sample Cup Palm-Held Ring and Sleeve Fastener



Held in the palm, this handy device effortlessly aids in attaching thin-film sample support windows to Chemplex XRF Sample Cups with “Snap-On Rings” and TrimLess® Sleeves. Averts contamination by contact during assembly, allows uniform application of pressure, eliminates Snap-On Ring and Sleeve misalignment, ensures taut thin-film sample support planes and is easy on the thumbs for multiple sample preparations.

### Double Open-Ended Sample Cups

Center a thin-film sample support substance across the appropriate open end of the sample cup. Position the Palm Held Fastener over the window film and apply a gentle downward pressure until attachment is completed. Transfer the sample cup with the attached window faced downward into an available cavity in a [Sample Cup Work Station](#) until ready to introduce a sample substance preferably with a [Transfer Pipette](#) for liquids to ensure equal volume dispensing. Depending upon the sample cup feature a vented cover lid may be attached to the open end, covered with Microporous Film or left uncovered in accordance with laboratory procedures.

### Single Open-Ended Sample Cups

Place a the closed end of a sample cup on a counter top surface and introduce a liquid sample preferably with a [Transfer Pipette](#) for liquids to ensure equal volume presentations for analysis. Center a thin-film sample support substance over the open end of the sample cup. Position the Palm Held Fastener over the window film and apply a gentle downward pressure until the attachment is completed. Turn the sample cup containing the sample upside down and insert in an available cavity in a [Sample Cup Work Station](#) in readiness to establish a venting means for pressure differential equalizing air, inert gas or evacuated conditions.

Palm Held Fastener Cat. No.	Usable with the Following Chemplex XRF Sample Cups
1325	1330, 1330SE, 1340, 1430, 1430SE, 1440, 1440L, 1530, 1530SE, 1540, 1730, 1730SE, 1740, 1830, 1830SE, 1840, 1850, 1930, 1930SE, 1940, 1940L
1327	1060, 1065, 2131, 2132
1329	2135
1331	1070, 1075, 2140, 2143, 2144
1333	1080, 1083, 1085
1335	1095, 2145, 2146, 2195

Palm Held Fastener Catalog Number	Description
1325	Palm Held “Snap-On Ring” Sample Cup Fastener
1327	Palm Held TrimLess® Sample Cup Sleeve Fastener
1329	Palm Held TrimLess® Sample Cup Sleeve Fastener
1331	Palm Held TrimLess® Sample Cup Sleeve Fastener
1333	Palm Held TrimLess® Sample Cup Sleeve Fastener
1335	Palm Held TrimLess® Sample Cup Sleeve Fastener

## XRF Sample Cup Vent-Hole Punch

Sample Cups and Accessories
Thin-Film Sample Supports
Grinding Machines and Accessories
Briquetting Presses and Accessories
Grinding/Briquetting Additives
Fusion Machines and Accessories
Standards and XRF/XRD Chemical Kits



The Vent-Hole Punch is a handy palm held device that facilitates creating a hole through sample cups for equalizing pressure differentials. It is designed for placement directly over sample cups integrating central ThermoPlastic™ seals. A simple downward pressure of the knob extends a pointed shaft the correct distance to create a hole. The spring-loaded awl automatically retracts in readiness for additional preparations. Ideally suitable for preparing numerous samples requiring venting.

After puncturing vent hole, rest each sample cup with the thin-film sample support window faced downward in a [Sample Cup Work Station](#) to prevent contamination to the window film in readiness for analysis.

### Use Vent Hole Punches with the Following Chemplex XRF Sample Cups

Sample Cup Cat. No.	Sample Cup Cat. No.	Sample Cup Cat. No.
1065	1430	1830
1075	1430 SE	1830 SE
1083	1440	1840
1085	1440L	1850

### SPECIFICATIONS AND ORDERING INFORMATION

Catalog Number	Description
1350	Vent-Hole Punch

- Sample Cups and Accessories
- Thin-Film Sample Supports
- Grinding Machines and Accessories
- Briquetting Presses and Accessories
- Grinding/Briquetting Additives
- Fusion Machines and Accessories
- Standards and XRF/XRD Chemical Kits

**XRF Sample Cup Vented “Snap-On” Cap  
FOR 1500 SERIES XRF SAMPLE CUPS**



The interior ridges form circular baffles when assembled to a sample cup. The baffles present physical barrier designed to retard or eliminate sample particles from escaping.

Vented Sample Cup Caps are designed for use with the Chemplex [1500 Series Sample Cups](#). When assembled, a series of physical barriers is established within the sample cup and interior of the sample cup cap. The barriers form a complicated path of travel for sample particles to reach the four venting slits. In evacuated conditions, non-volatile liquids and powdered sample particles are unlikely able to continue and complete their tortuous travel path impeded by barriers. Pressure equilibrium is therefore established between the interior sample cup and sample chamber while the sample material remains confined within the sample cup. Thin-film sample support windows remain taut resulting in flat sample support planes.

The interior of the Sample Cup Cap integrates a circular trough formed by the outer wall and a raised ridge within the Cap. A hollow is similarly formed within the center of the cup that helps in particle deflection back into the sample cup.

When attached to a corresponding diameter size sample cup, the Cell Neck of the sample cup fits into the trough of the Sample Cup Cap. The combination of the two part assembly creates two separate circular troughs separated from each other by the Cell Neck and raised ridge of the Sample Cup Cap. The separation between the two formed ridges, or baffles, suffices for evacuation of the sample cup through the four integrated vent slits but presents difficulty for powdered sample particles to freely travel owing to the baffles and tortuous path of travel.

Affix a thin-film sample support window to the Cell neck opposite the flanged end. Insert sample substance. Attach Sample Cup Cap to the open end of the Cell with the flange around the outside diameter.

CAT. NO.	DESCRIPTION	NOMINAL OUTSIDE DIAMETER mm	USE WITH LISTED CAT. NO. OF SAMPLE CUP	CAPS/ PKG
1630	Vented Sample	32	For Use With: <a href="#">1530</a> Cups	100
1640	Cup Caps	40	For Use With: <a href="#">1540</a> Cups	100

- Sample Cups and Accessories
- Thin-Film Sample Supports
- Grinding Machines and Accessories
- Briquetting Presses and Accessories
- Grinding/Briquetting Additives
- Fusion Machines and Accessories
- Standards and XRF/XRD Chemical Kits

## GyralGrinder® XRF Sample Grinding Machine

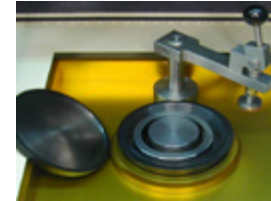
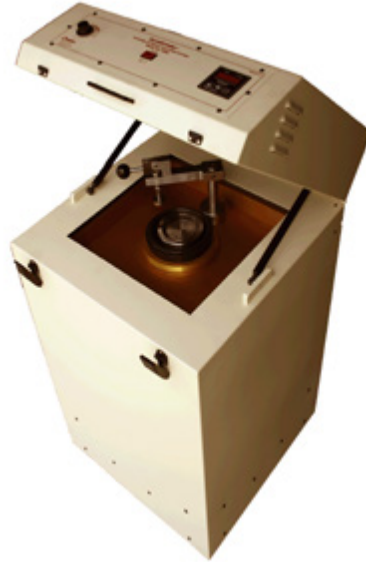

Clamping mechanism swings backwards and out of the way for full access to comminution dish.

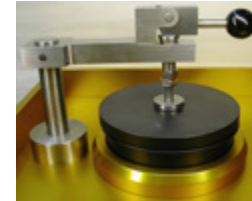

Single level clamping mechanism firmly locks comminution dish in position.

GyralGrinder® powdered sample grinder reduces innumerable types of samples to a uniform particle size, shape and distribution for XRF analysis in just minutes. The grinding process is extremely energetic, fast and thorough.

Uniquely engineered gyral-mechanics impart a controlled imbalanced condition to the grinding dish containing a sample substance. The components of the grinding dish, a puck and ring, energetically strike and crush the sample while continuously encouraging the particles to intermix with each other. The GyralGrinder® grinding machine is ergonomically designed for operator comfort and easy access to the working chamber and controls.

### EASY ACCESS TO CONTROLS

All operating controls are located within easy reach on the lid. A single push button switch turns the unit on or off. The programmable solid-state electronic timer has a large LED display for elapsed time and audible alarm for alerting completion of the comminution cycle. A rotary switch controls the intensity of impact.



### USER-FRIENDLY OPERATION

The control lid lifts upward and toward the rear. It is supported by two gas compression springs. A safety switch automatically disengages the unit if the lid is inadvertently opened. Two safety latches firmly locks down the control lid during operation.

The comminution dish firmly clamps in position using a single one-hand operated lever that also swings away for full accessibility to the sample chamber. A self-locking mechanism is designed into the lever that prevents the dish from dislodging during operation. Simply pull out on the knob and lift the handle up to disengage locking mechanism allowing the entire arm assembly to swing out of the way toward the rear of the chamber.

The Intensity of Impact Control rotary switch is numbered from 1 through 10, with 10 representing the greatest intensity of impact. This control allows for the comminution of a wide range of sample materials extending from soft to very hard. It provides a means to minimize the introduction of transition element contamination to the sample and wear to the grinding vessels.



### COMMUNITION VESSELS FOR GYRALGRINDERS

Hardened steel, tungsten carbide and zirconia comminution vessels are configured specifically to function with the GyralGrinder® clamping mechanism. The dishes incorporate an upper ridge for ease of handling and the lids have a central depression for self-alignment and fixation in position.

Cat. No.	External Dimensions	Internal Dimensions	Capacity with Puck and Ring Assembled	Weight
Annealed Steel	6.4"D; 2.5"H	1.83" H x 5.69" Dia.	360 cc	17 lbs
Tungsten Carbide	6.4"D; 2.5"H	1.76" H x 5.18" Dia.	290 cc	21 lbs
Zirconia Ceramic	6.4"D; 2.5"H	1.76" H x 5.18" Dia.	290 cc	11 lbs

\* Tungsten carbide and zirconia are prone to chipping and fractures and supplied without any warranty expressed or implied.

## GyralGrinder® XRF Sample Grinding Machine

### STANDARD ATTRIBUTES

Sample Cups and Accessories
Thin-Film Sample Supports
<b>Grinding Machines and Accessories</b>
Briquetting Presses and Accessories
Grinding/Briquetting Additives
Fusion Machines and Accessories
Standards and XRF/XRD Chemical Kits

CE certified  
 Variable Intensity of Impact Control extends range of processing different types of samples  
 Reduces grinding dish wear and transition element contamination to sample  
 Digital programmable timer with LCD display ensures highly accurate and reproducible cycles  
 Cycle completion alarm and LED light  
 Single lever grinding dish-locking mechanism facilitates sample introduction and removal  
 Sound abatement throughout reduces noise level  
 3/4 horse power DC motor resists wear and generates virtually no heat  
 Solid-state motor control, integrated AC to DC converter, single phase  
 Heavy gauge steel cabinet and gas springs support lid for unobstructed working chamber access  
 Single moving part engineering for virtually service-free operation  
 Ergonomically designed for operator comfort  
 Safety features disengage operation when lid or service panel is opened

### TYPICAL APPLICATIONS

Catalysts Cement Chemicals Clinkers Coal Coke Concrete Ferro-alloys Fertilizer Fluxes Glass Iron ores Limestone Minerals Pesticides Ores Raw Mix Refractories Rocks Sand Sinters Slags Dry Soil And many other substances requiring uniform particle size reduction, configuration and distribution for homogeneous XRF samples in reduced time and effort.

### TYPICAL GRINDING TEST RESULTS WITH CHEMPLEX GYRALGRINDER® MACHINES

Substance	Initial Size	Intensity of Impact	Wt. % Passing Through 44 micron Screen	Grinding Time, minutes
Asbestos	Fibers	High	100	9
Cement, Portland	> 60 mesh	Moderate	100	4
Ferro-chromium	> 100 mesh	High	100	6
Ferro-manganese	> 200 mesh	High	100	5
Ferro-molybdenum	< 80 mesh	High	100	8
Ferro-niobium	< 80 mesh	High	100	5
Ferro-silicon	< 80 mesh	Moderate	100	6
Ferro-titanium	< 80 mesh	Moderate	100	7
Fiberglass	Fibers	Moderate	100	4
Fluorspar	> 100 mesh	Moderate	100	5
Glass, soda lime	Chunks	Low	100	6
Graphite	Fiber	Low	100	4
Oil Shale	5 mm	Low	100	5
Phosphate	> 60 mesh	Low	100	4
Silicon dioxide	< 10 mesh	Moderate	100	4
Slag, blast furnace	Chunks	High	100	7

**Note:** The information described in the aforementioned chart is provided to serve as guide; it insinuates the potential performance of the comminution machine and does not necessarily represent or imply a sample preparation procedure or actuality owing to wide variations within sample types. Judicial independent testing and empirical investigation of individual samples to singularly or in conjunction with other techniques or devices to evaluate and determine the most appropriate operating conditions are recommended.

### SPECIFICATIONS AND ORDERING INFORMATION

Cat. No.	Description	Dimensions	Weight
5000-115	GyralGrinder® Sample Grinder with Intensity of Impact Control; 115 VAC/60HZ	24"x 24" x 43"	446 lbs
5000-230	GyralGrinder® Sample Grinder with Intensity of Impact Control; 230 VAC/50HZ	24"x 24" x 43"	446 lbs

Single Phase; DC ¾ HP Motor

- Sample Cups and Accessories
- Thin-Film Sample Supports
- Grinding Machines and Accessories
- Briquetting Presses and Accessories
- Grinding/Briquetting Additives
- Fusion Machines and Accessories
- Standards and XRF/XRD Chemical Kits

## SpectroMill® XRF Sample Grinding and Blending Machines



**SpectroMill-I**

Processes One or More Samples Simultaneously with a [SpectroVial Adapter](#)



**SpectroMill-II**

Processes Two or More Samples Simultaneously with [SpectroVial Adapters](#)

SpectroMill® Ball Pestle Impact Grinders operate on the principle of propelling one or more ball pestles together with a sample substance from one end of a [SpectroVial®](#) brand comminution vial to the opposite end in a rotary “figure-8” path of travel configuration. The motion is energetic and rapid.

The sample is crushed by the ball pestle and “mulled” as the ball pestle is guided across the concaved interior ends of the vial to repeat the cycle on the opposite end. The comminution and blending processes are controlled by type of sample substance, quantity, time, hardness of the vial and number of ball pestles.

The SpectroMill® Ball Pestle Impact Grinder incorporates “well-balanced” engineering that permits high degrees of stability for counter top operation. A programmable digital electronic timer controls processing time with a LED and audible alarm indicating cycle completion.

Two SpectroMill® versions are available. SpectroMill-I has a single variable vial clamping mechanism that can accommodate one sample or several with a [SpectroVial® Single and Multi-Vial Adapter](#). SpectroMill-II has two variable vial clamping mechanisms for handling similar or dissimilar types of samples. Use of a SpectroVial® Adaptor extends the number of samples processed at the same time.

SpectroVial®™ comminution vials are engineered for use with SpectroMills I and II. Refer to [SpectroVial®](#) brand listing for details of complete product line.

### SPECIFICATIONS AND ORDERING INFORMATION

Cat. No.	Description	Dimensions	Weight
1100-115	SpectroMill® – I Ball Pestle Impact Grinder; single vial clamp; 115 Vac/60 Hz	15¼” x 17” x 12½”	79¼ lbs
1100-230	SpectroMill® – I Ball Pestle Impact Grinder; single vial clamp; 230 Vac/50 Hz	15¼” x 17” x 12½”	79¼ lbs
1111-115	SpectroMill® – II Ball Pestle Impact Grinder; double vial clamps; 115 Vac/60 Hz	26½” x 15½” x 11½”	86¼ lbs
1111-230	SpectroMill® – II Ball Pestle Impact Grinder; double vial clamps; 230 Vac/50 Hz	26½” x 15½” x 11½”	86¼ lbs

**SpectroVial® XRF Sample Grinding and Blending Vials**

- Sample Cups and Accessories
- Thin-Film Sample Supports
- Grinding Machines and Accessories
- Briquetting Presses and Accessories
- Grinding/Briquetting Additives
- Fusion Machines and Accessories
- Standards and XRF/XRD Chemical Kits



Chemplex® offers a wide selection of SpectroVial® comminution and blending vials for use with its SpectroMill® Ball Pestle Impact Grinders. They are available in a variety of sizes and material substances to accommodate a wide variety of sample materials. All SpectroVial® designs are unique with concaved interior ends in both the body and cap that are also fabricated from the same material. Corresponding ball pestles are also available and offered in compatible materials to the vials.

The importance of concaved interior ends is to ensure that no sample particles can elude the ball pestle comminution process by entrapment and caking in the corners similar to the expected events with the use of traditional “medicine” vials.

The mechanics of the SpectroMill® Ball Pestle Impact Grinders are designed to propel one or more ball pestles through a “figure-8” path of travel for impact against the curved interior ends of the vials. The spherical shape of the balls is responsible for sample “mulling” against the curvature of the interior vial ends.

The combination of ball pestle impacts and mulling actions effectively comminute the sample substance for uniformity of particle size, configuration and distribution producing a thoroughly homogeneous mixture.

**SPECIFICATIONS AND ORDERING INFORMATION**

**SpectroVial® Polystyrene Vials**

Crystal clear, hard and rigid; thick walled and reinforced ribbed exterior ends; designed to withstand repeated ball pestle impact. Friction fitting caps have tabs that facilitate assembly and disassembly. Ideal for blending applications and suitable for comminuting soft sample materials. [Methylmethacrylate ball pestles](#) are suggested.

Cat. No.	Recommended Sample Quantity	Length	Diameter	Recommended Ball Pestles	Qty /Pkg
1121	1-2 cm <sup>3</sup>	48mm	15mm	1205	100 sets
1122	2-5 cm <sup>3</sup>	48mm	22mm	1207	100 set
1133	5-10 cm <sup>3</sup>	75mm	26mm	1208	100 sets
1134	10-20 cm <sup>3</sup>	75mm	33mm	1211	100 sets

**SpectroVial® Stainless Steel Comminution and Blending Vials**

General purpose comminuting and blending moderately hard samples applications. Threaded caps have concaved interior ends. [Stainless steel ball pestles](#) suggested.

Cat. No.	Recommended Sample Quantity	Length	Diameter	Recommended Ball Pestles	Qty /Pkg
1161	1-2 cm <sup>3</sup>	51mm	16mm	1245	1 unit
1162	2-5 cm <sup>3</sup>	51mm	22mm	1247	1 unit
1173	5-10 cm <sup>3</sup>	76mm	26mm	1248	1 unit
1174	10-20 cm <sup>3</sup>	84mm	38mm	1251 & 1252	1 unit
1175*	10-30 cm <sup>3</sup>	66mm	54mm	1247 & 1252	1 unit

\* Supplied as a single open-ended vial.

SPECIFICATIONS AND ORDERING INFORMATION

- Sample Cups and Accessories
- Thin-Film Sample Supports
- Grinding Machines and Accessories
- Briquetting Presses and Accessories
- Grinding/Briquetting Additives
- Fusion Machines and Accessories
- Standards and XRF/XRD Chemical Kits

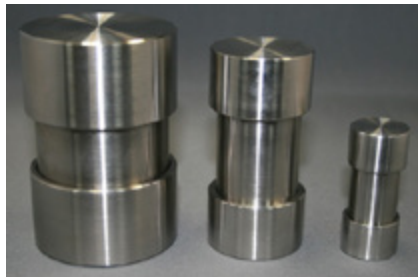

**Rust Resistant Stainless Steel SlipFit™ Comminution and Blending Vials**

SlipFit® stainless steel vials are used for general purpose comminuting and blending moderately hard samples. These SpectroVial® comminuting and blending vials also have the added convenience of easily slipping the caps onto the vial bodies. They are fabricated from a rust-resistant stainless steel for cleansing with water and easy cleanups. Interior ends of both caps and vial bodies are concaved. Stainless steel ball pestles suggested.

SPECIFICATIONS AND ORDERING INFORMATION

Cat. No.	Recommended Sample Quantity	Length	Diameter	Recommended Ball Pestles	Qty /Pkg
1143	1-8 cm <sup>3</sup>	55mm	22mm	1247	1 unit
1146	5-15 cm <sup>3</sup>	84mm	38mm	1252	1 unit
1149	12-30 cm <sup>3</sup>	94mm	56mm	1252	1 unit

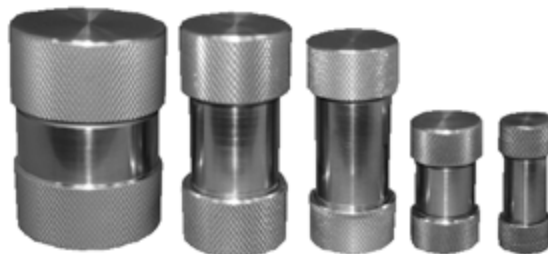

**SpectroVial® Titanium Carbide Comminution and Blending Vials**

Titanium carbide is an exceptionally hard substance having a Rockwell “C” hardness similar to tungsten carbide that makes it very suitable to process very hard sample materials. The threaded caps and vials have concaved interior ends. Titanium carbide is prone to fracture and is supplied without any warranty expressed or implied. [Tungsten carbide ball pestles](#) suggested.

SPECIFICATIONS AND ORDERING INFORMATION

Cat. No.	Recommended Sample Quantity	Length	Diameter	Recommended Ball Pestles	Qty/Pkg
1151	1-2 cm <sup>3</sup>	54mm	16mm	1235	1 unit
1152	2-5 cm <sup>3</sup>	57mm	22mm	1236	1 unit
1153	5-10 cm <sup>3</sup>	84mm	27mm	1237	1 unit
1154	10-20 cm <sup>3</sup>	84mm	33mm	1238 & 1239	1 unit

## SpectroVial<sup>®</sup> XRF Sample Grinding and Blending Ball Pestles

Sample Cups  
and Accessories

Thin-Film  
Sample Supports

Grinding Machines  
and Accessories

Briquetting Presses  
and Accessories

Grinding/Briquetting  
Additives

Fusion Machines  
and Accessories

Standards and  
XRF/XRD Chemical Kits

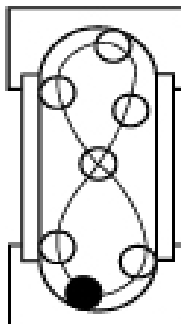

Ball pestles serve as the grinding media in conjunction with the use of SpectroVial<sup>®</sup> comminuting and blending vials for comminuting powdered material substances in SpectroMill<sup>®</sup> Ball Pestle Impact Grinders. The selection of a ball pestle material is a function of the type of SpectroVial in use.

Plastic methylmethacrylate ball pestles are intended to be used with plastic SpectroVial<sup>®</sup> polystyrene vials. By comparison to SpectroVial<sup>™</sup> metallic comminution vials and their corresponding ball pestles, plastic is relatively soft and not very effective in the comminution process. Its principal application is for blending sample material substances or for comminuting soft samples.

Stainless steel metallic ball pestles are primarily used for comminuting relatively hard sample substances. Tungsten carbide ball pestles in combination with SpectroVial<sup>™</sup> titanium carbide vials are much more effective grinding media for extremely hard samples.

The effectiveness of the comminution process to achieve an analytically acceptable particle size is a function of the initial sample charge, type of comminution vial and ball pestle materials, number of ball pestles and processing time. Empirical testing and evaluation is recommended to ascertain the best statistically reproducible x-ray analytical data.

### SPECIFICATIONS AND ORDERING INFORMATION

#### Plastic Methyl Methacrylate Ball Pestles

Cat. No.	Diameter, mm	Qty/Pkg
1205	5	100
1207	7	100
1208	8	100
1211	11	100

#### Stainless Steel Ball Pestles

Cat. No.	Diameter, mm	Qty/Pkg
1245	5	6
1247	7	6
1248	8	6
1251	11	6
1252	12.7	6

#### Tungsten Carbide Ball Pestles

Cat. No.	Diameter, mm	Qty/Pkg
1235	5	6
1236	7	6
1237	8	6
1238	11	6
1239	12.7	6

- Sample Cups and Accessories
- Thin-Film Sample Supports
- Grinding Machines and Accessories
- Briquetting Presses and Accessories
- Grinding/Briquetting Additives
- Fusion Machines and Accessories
- Standards and XRF/XRD Chemical Kits

**SpectroVial<sup>®</sup> Adaptors for Extending SpectroMill<sup>®</sup> Sample Processing Range**



The SpectroVial<sup>®</sup> Adaptor extends the number of samples accommodated by SpectroMill<sup>®</sup> Ball Pestle Impact Grinders. Simply insert SpectroVial<sup>®</sup> brand comminution and blending vials into cavities and place entire assembly in the SpectroMill<sup>®</sup> grinding/blending machine variable vial clamping mechanism for processing in the usual manner.

This handy device is very useful for comminuting and blending similar or completely different samples at the same time in the SpectroMill-I and SpectroMill-II version machines. Notably extends the applications of the SpectroMill machines and saves time.

**SPECIFICATIONS AND ORDERING INFORMATION**

Cat. No.	Description	Number of Cavities	Accommodates SpectroVial <sup>®</sup> Cat. No.
1181	SpectroVial <sup>®</sup>	1	1122, 1133, 1143, 1151, 1152, 1162
1183	Adaptor	3	1122, 1133, 1143, 1152, 1162
1185		5	1121, 1152, 1161

© SpectroVial, SpectroMill and Chemplex are registered trademarks of Chemplex Industries, Inc.

**Chemplex<sup>®</sup> INDUSTRIES, INC.**  
2820 SW 42<sup>nd</sup> Avenue  
Palm City, Fl. 34990-5573, USA

Continental USA Toll Free: (800) 4-CHEMPLEX  
Phone: (772) 283-2700  
Email: [sales@chemplex.com](mailto:sales@chemplex.com)

Fax: (772) 283-2774  
On Line Sales: <http://www.chemplex.com>

## Impact Mortar and Pestle Sets

Sample Cups  
and Accessories

Thin-Film  
Sample Supports

Grinding Machines  
and Accessories

Briquetting Presses  
and Accessories

Grinding/Briquetting  
Additives

Fusion Machines  
and Accessories

Standards and  
XRF/XRD Chemical Kits



Cat. No: 850; Large Mortar and Pestle Set

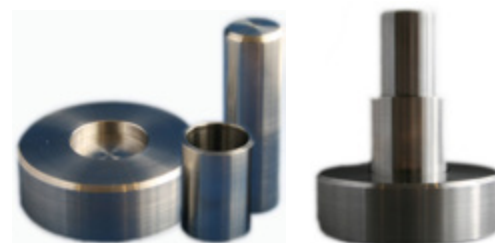

Cat. No: 845; Small Mortar and Pestle Set

Rocks and other agglomerated types of sample materials are seldom of suitable size for accommodation and direct comminution in SpectroMill® Ball Pestle Impact Grinder vials or GyralGrinder® comminution vessels. Quite often it is necessary to first crush a sample into smaller constituents. The Impact Mortar and Pestle is ideally suited for this application in the laboratory or for field collections.

### Easy and Convenient To Use

Simply place the sample in the mortar chamber. Insert the pestle and repeatedly raise and lower the pestle with controlled force. The contained sample is mechanically crushed with each downward stroke. Use of a wood or plastic mallet is a useful consideration.

### Two Different Volumetric Capacities

Two different sizes are available to accommodate a wide range of sample quantities of various densities for subsequent formation into self-supported 32, 35, 40 and 45mm diameter sample briquettes.

#### SPECIFICATIONS AND ORDERING INFORMATION

Cat. No.	Description	Sample Capacity	Weight
845	Small Impact Mortar and Pestle Set (Hardened Steel)	13 cm <sup>3</sup> ; 0.8 in <sup>3</sup>	1.2 kg; 2.6 lb
850	Large Impact Mortar and Pestle Set (Stainless and Hardened Chrome Steel)	70 cm <sup>3</sup> ; 5 in <sup>3</sup>	4.0 kg; 8.8 lb

**Note: Not guaranteed against chipping. Safety goggles and personal protective wear are recommended.**

## Traditional Agate Mortar and Pestle Sets

Sample Cups  
and Accessories

Thin-Film  
Sample Supports

Grinding Machines  
and Accessories

Briquetting Presses  
and Accessories

Grinding/Briquetting  
Additives

Fusion Machines  
and Accessories

Standards and  
XRF/XRD Chemical Kits

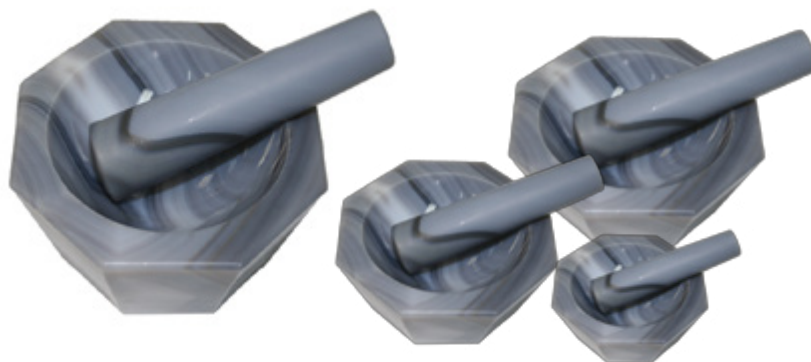

Agate is a naturally occurring form of quartz noted for its extremely high degree of resistance to abrasion, wear and superior hardness; on the MOHS scale its hardness is 6 to 7.

The principal composition of agate is silicon with minor element constituents each typically less than 0.02% of magnesium, aluminum, sodium, calcium, iron and potassium. Collectively, this permits a diversified number of sample substances of differing hardness to be safely and effectively comminuted with a minimal amount of contamination to the sample.

Agate is also very resistant to most chemicals with the exception of hydrofluoric acid that tends to etch the material. Each mortar and pestle is meticulously polished to a high degree to avert potential sample particle entrapment and cross contamination from successive sample processing.

### SPECIFICATIONS AND ORDERING INFORMATION

CAT. NO.	DIAMETER
8050	1.97" (50 mm)
8100	3.94" (100 mm)
8150	5.91" (150 mm)
8200	7.87" (200 mm)

**Note:** Agate is an extremely hard substance prone to fracture in handling or when subject to impact and/or extremities in temperature. Extra care should be exercised in the judicious use and applications of these products. They are not guaranteed against fracture or breakage. The buyer assumes full responsibility in the purchase and use of these products irregardless of their suggested use. Chemplex Industries, Inc. assumes no responsibility whatsoever.

## SpectroPress® Briquetting Press Comparison Chart

- Sample Cups and Accessories
- Thin-Film Sample Supports
- Grinding Machines and Accessories
- Briquetting Presses and Accessories
- Grinding/Briquetting Additives
- Fusion Machines and Accessories
- Standards and XRF/XRD Chemical Kits

Chemplex SpectroPress® Models are divided into five main categories that include specific standard attributes. Referral to the SpectroPress® Models Comparison Chart is intended to serve as a guide in the initial selection process based on filling the needs of the individual laboratory. Full individual product descriptions are offered in their respective data sheets that are accessible by selecting the related heading listed at the top of each column.

Standard Features	Manual 12 Ton Model	Semi-Automatic 30 Ton Model	Semi-Automatic 40 Ton Model	Semi-Automatic 30 Ton Model With "Manually Operated Integrated Die"	Automatic 40 Ton Model With "Automated Integrated Die Assembly"
Integrated Die and Components	No	No	No	Includes choice of 32, 35 or 40 mm integrated die and manually operated components	Includes choice of 32, 35 or 40 mm integrated die and automated components
Standard 32, 35, 40 and 45 mm Die Accommodation	Optional 13, 32, 35, 40 and 45 mm Die Sets	Optional Standard 32, 35, 40 or 45 mm Die Sets	Optional Standard 32, 35, 40 or 45 mm Die Sets		
PelletCups® Accommodation and Recommendation	Yes: Optional Standard 32, 35, 40 or 45 mm	Yes: Optional Standard 32, 35, 40 or 45 mm	Yes; Optional Standard 32, 35, 40 or 45 mm	Yes; Optional Standard 32, 35 or 40 mm	Yes; Optional Standard 32, 35 or 40 mm
Read Out	Analog	Analog	Digital	Analog	Digital
Touch-Screen Operating and Programming Key Functions Programmable	No	No	Yes	No	Yes
Force, 0.1 tons increments Programmable	No	No; Operator Selectable	Touch-Screen Programmable	No; Operator Selectable	Touch-Screen Programmable
Dwell Time, 0.1 min. increments	No	No; Operator Selectable	Touch-Screen Programmable	Operator Selectable	Touch-Screen Programmable
Adjustable Density Control	Yes	Yes	Yes	No	No
Self-Centering Standard Die Size Platen	Yes	Yes	Yes	N/A	N/A
Countertop Installation	Yes	Yes	Yes	Yes	Yes
Solid Steel Side Slabs	No	Yes	Yes	Yes	Yes
Interlocked Safety-Door	No	No	No	Yes	Yes
Animated Touch-Screen Operating Status	No	No	Yes	No	Yes
Audible Cycle Completion Alert	No	No	Yes	No	Yes
Diagnostics Alert	No	No	Yes	No	Yes
Illuminated Working Chamber	No	115 VAC Model	Yes	115 VAC Model	Yes
SpectroCertified Force Accuracy	Yes	Yes	Yes	Yes	Yes
Microprocessor	No	No	Yes	No	Yes
Safety Interlocks	No	No	Yes	No	Yes

**SpectroPress® Automatic AIDA 40 Ton Briquetting Press**  
Automated Integrated Die Assembly (AIDA), Touch-Screen Key Functions,  
Programmable Force & Dwell Time

- Sample Cups and Accessories
- Thin-Film Sample Supports
- Grinding Machines and Accessories
- Briquetting Presses and Accessories
- Grinding/Briquetting Additives
- Fusion Machines and Accessories
- Standards and XRF/XRD Chemical Kits



Engineered for unattended high-performance for briquetting repetitive powdered samples to a standardized diameter



Automated Integrated Die Assembly (AIDA) eliminates die removal and disassembly to extract the sample pellet.



Touch-screen operating function key, digital force indicator, pump and ram status



Touch-screen diagnosis and comment

This SpectroPress® AIDA Model is the most technologically advanced powdered sample briquetting press. It is fully automatic from powdered sample introduction to removal of a sample briquette just moments later without intervention. It is designed for busy laboratories requiring repetitive briquetting to a standardized 32, 35 or 40 mm diameter.

**Automatic SpectroPress® Utilizes "Automated Integrated Die Assembly" (AIDA) Technology**

**Completely Automatic Single "Start" Key Function Eliminates Die Handling Includes Die Size of Choice Programmable Force Programmable Dwell Time Digital Display**

The amazing performance of the AIDA model is attributed to the Chemplex® development of "Automated Integrated Die Assembly" (AIDA) technology. This critical aspect together with state-of-the-art electronics is responsible for the complete automation of the powdered sample briquetting process, high sample through-put and simplicity of operation.

The use of optional compressible tapered aluminum [PelletCups®](#) is mandatory for effective automation.

**Standard Features**

- Automated Integrated Die Assembly (AIDA)
- Includes integrated die of choice: 32, 35 or 40 mm
- Single "Start" touch-screen function key initiates the automatic briquetting process
- Touch-screen programmable force selection and digital display in 0.1 ton increments up to 40 tons
- Touch-screen programmable dwell time option selection and digital display in 0.1 minute increments up to 10 minutes
- Operating function and diagnostic alerts
- Animated touch-screen symbols simulate status of hydraulics and ram position
- Small footprint for countertop installations
- Sturdy solid steel side construction
- Side-hinged interlocked safety door
- Audible cycle completion alert
- Illuminated working chamber
- SpectroCertified® force accuracy

**Specifications**

Dimensions: 10.7" wide x 14.6" deep x 16.9" high (27.1 cm x 37.1 cm x 42.9 cm)  
 Weight: 220 lbs (100 kg)  
 Force: 40.0 tons; 0.1 ton increments  
 Dwell Time: 10 minutes maximum; 0.1 minute increments  
 Electrical: 115 VAC/60 HZ or 230 VAC/50 Hz availability  
 Electronics: Solid state; touch-screen function keys; microprocessor

Cat. No.	Description
4432-115	SpectroPress® Automatic "AIDA" 40 Ton with 32 mm Integrated Die Set; 115VAC/60Hz
4432-230	SpectroPress® Automatic "AIDA" 40 Ton with 32 mm Integrated Die Set; 230VAC/50Hz
4435-115	SpectroPress® Automatic "AIDA" 40 Ton with 35 mm Integrated Die Set; 115VAC/60Hz
4435-230	SpectroPress® Automatic "AIDA" 40 Ton with 35 mm Integrated Die Set; 230VAC/50Hz
4440-115	SpectroPress® Automatic "AIDA" 40 Ton with 40 mm Integrated Die Set; 115VAC/60Hz
4440-230	SpectroPress® Automatic "AIDA" 40 Ton with 40 mm Integrated Die Set; 230VAC/50Hz

- Sample Cups and Accessories
- Thin-Film Sample Supports
- Grinding Machines and Accessories
- Briquetting Presses and Accessories**
- Grinding/Briquetting Additives
- Fusion Machines and Accessories
- Standards and XRF/XRD Chemical Kits

## SpectroPress® Semi-Automatic 40 Ton Pellet Press

### Touch-Screen Control, Programmable Force & Dwell Time, Flexibility of Different Die Set Size Use



**Optionally available 13, 32, 35, 40 and 45 mm Chemplex® evacuable annealed stainless steel die sets**



Automated Integrated Die Assembly (AIDA) eliminates die removal and disassembly to extract the sample pellet.



Touch-screen operating function key, digital force indicator, pump and ram status



Touch-screen diagnosis and comment

The Standard 40 Ton Force SpectroPress® Model allows the flexibility of briquetting powdered samples to different diameters by accommodating a variety of standard die set sizes. All operating parameters are easily performed and programmable through touch-screen key functions and digital readouts.

**Semi-Automatic SpectroPress® Model Extends Powdered Sample Briquetting Capabilities**

- Accepts Different Die Size Sets
- Adjustable Die Height Arbor
- Single "Start" Key Function
- Programmable Force
- Programmable Dwell Time
- Touch-Screen Entry Functions
- Illuminated Sample Chamber



Unique platen accepts, self-aligns and self-centers all Chemplex® optionally available die sizes

The Semi-Automatic SpectroPress® Model incorporates features that provide the analyst with control of the operating parameters through touch-screen key entries. Up to 40 tons of force in 0.1 ton increments and dwell time up to ten minutes in 0.1 minute increments are programmable. The option of engaging dwell allows briquetting samples with tendencies to develop fissures time to adjust to their newly compressed state.

Different standard Chemplex® 13, 32, 35, 40 and 45 mm [stainless steel die sets](#) are easily interchanged and self-aligned in a platen with counter-bores corresponding to the die set size. A threaded arbor with a large knurled knob enables the adjustability of the volumetric capacity of the die chamber. This feature accounts for variations in sample density to enable uniformity of sample pellet thickness.

#### Standard Features

- Flexibility to interchange die set size
- Adjustable volumetric die capacity with arbor control
- Self-centering and aligning die platen
- Simple touch-screen key operating and programming functions
- Programmable force selection and digital display in 0.1 ton increments up to 40 tons
- Programmable dwell time selection option and digital display in 0.1 minute increments up to 10 minutes
- Animated touch-screen symbols simulate status of hydraulics and ram position
- Operating functions and diagnostics alerts
- Small footprint for countertop installations
- Sturdy solid steel slab construction
- Side-hinged interlocked safety door
- Audible cycle completion alert sound
- Illuminated working chamber
- SpectroCertified® force accuracy

#### Specifications

Dimensions: 10.7" wide x 14.6" deep x 16.9" high (27.1 cm x 37.1 cm x 42.9 cm)  
 Weight: 220 lbs (100 kg)  
 Force: 40 tons maximum; 0.1 ton increments  
 Dwell Time: 10 minutes maximum; 0.1 minute increments  
 Electrical: 115 VAC/60 HZ or 230 VAC/50 Hz  
 Electronics: Solid state; touch-screen function keys; microprocessor

#### Ordering Information

Cat. No.	Description
4400-115	Semi-Automatic 40 Ton SpectroPress® Touch-Screen Model; 115VAC/60Hz
4400-230	Semi-Automatic 40 Ton SpectroPress® Touch-Screen Model; 230VAC/50Hz

Sample Cups  
and Accessories

Thin-Film  
Sample Supports

Grinding Machines  
and Accessories

Briquetting Presses  
and Accessories

Grinding/Briquetting  
Additives

Fusion Machines  
and Accessories

Standards and  
XRF/XRD Chemical Kits

## SpectroPress<sup>®</sup> Semi-Automatic Integrated Die Assembly (IDA) 30 Ton Pellet Press



Includes integrated die size of choice: 32, 35 or 40 mm. Two momentary switch buttons control operation: "Up" for compression and "Down" for decompression. It's that simple and requires no die handling.

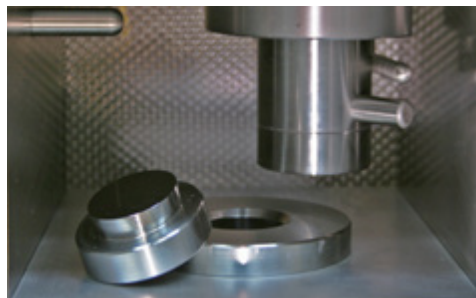

Manual Integrated Die Assembly (IDA) simplifies briquetting: place powdered sample on ram platform, depress "Down" button to lower sample into die chamber, insert die cap and swing anvil into position. Depress "Up" button to desired force.

A user selected die size is included with this Semi-Automatic 30 Ton SpectroPress<sup>®</sup> IDA model. For laboratories briquetting the same standardized diameter size XRF pellets, this model will perform with amazing speed, ease, convenience and reproducibility. To insert a powdered sample or remove the sample briquette, die removal is completely eliminated by means of an innovative manually operated "Integrated Die Assembly" (IDA) mechanism.

Two momentary buttons control the operation for briquetting, decompression and sample pellet ejection. Depressing the "Up" button raises the ram and the "Down" button retracts the ram. Analog gauge indicates force in one ton increments up to 30 tons.

For optionally applying dwell time, discontinue depressing the "Up" button at the desired force for a timed interval before depressing the "Down" button to implement decompression and pellet removal.

The use of optional compressible tapered aluminum Chemplex<sup>®</sup> PelletCups<sup>®</sup> briquetting cups is mandatory attributed to the precision and close manufacturing tolerances involved to avoid unnecessary spillage and damage during the briquetting process. Small compact design is ideal for counter top operation. Illuminated working chamber (on some models) improves visibility.

### FAST, EASY AND CONVENIENT TO USE

1. Place powdered sample in Chemplex<sup>®</sup> compressible tapered aluminum PelletCups<sup>®</sup> briquetting cups on ram.
2. Depress "Down" button until PelletCups<sup>®</sup> briquetting cup is retracted for Briquetting Cap insertion.
3. Insert stainless steel Briquetting Cap over the PelletCups<sup>®</sup> briquetting cup within the die body.
4. Rotate Anvil completely forward over the Briquetting Cap.
5. Depress "Up" button until desired force indicated in tons is attained.
6. If dwell is required remove pressure applied to "Up" button for a timed interval.
7. Depress "Down" button to retract the ram.
8. Rotate Anvil completely to its backward position.
9. Depress "Up" button to extract Briquetting Cap and briquetted pellet in preparation for introducing another sample.

### SPECIFICATIONS

Dimensions: 14.5" deep x 17.5" wide x 17" high (37 cm x 45 cm x 17 cm)  
Weight: 210 lbs (94.5 kg)

### ORDERING INFORMATION

Cat. No.	Description
4332-115	SpectroPress <sup>®</sup> Semi-Automatic 32mm Integrated Die Assembly 30 Ton Pellet Press; 115 VAC/60Hz
4332-230	SpectroPress <sup>®</sup> Semi-Automatic 32mm Integrated Die Assembly 30 Ton Pellet Press; 230 VAC/50Hz
4335-115	SpectroPress <sup>®</sup> Semi-Automatic 35mm Integrated Die Assembly 30 Ton Pellet Press; 115 VAC/60Hz
4335-230	SpectroPress <sup>®</sup> Semi-Automatic 35mm Integrated Die Assembly 30 Ton Pellet Press; 230 VAC/50Hz
4340-115	SpectroPress <sup>®</sup> Semi-Automatic 40mm Integrated Die Assembly 30 Ton Pellet Press; 115 VAC/60Hz
4340-230	SpectroPress <sup>®</sup> Semi-Automatic 40mm Integrated Die Assembly 30 Ton Pellet Press; 230 VAC/50Hz

## SpectroPress® Semi-Automatic 30 Ton Pellet Press

Sample Cups  
and Accessories

Thin-Film  
Sample Supports

Grinding Machines  
and Accessories

Briquetting Presses  
and Accessories

Grinding/Briquetting  
Additives

Fusion Machines  
and Accessories

Standards and  
XRF/XRD Chemical Kits



Knurled knob adjusts die plunger height to control volumetric capacity for accommodating different sample volumes to produce uniformly thick sample briquettes



Unique platen accepts, self-aligns and self-centers all Chemplex® optionally available die sizes

This model is easily adaptable to accept different size dies for laboratories requiring different sample briquette diameters.

Simple two button operation for briquetting, decompression and sample pellet ejection. Depress "Up" button for briquetting until desired force in tons is attained as indicated on the analog gauge. Analog gauge indicates force in one ton increments up to 30 tons.

For applying dwell time, discontinue depressing the "Up" button at the desired force for a timed interval before depressing the "Down" button for initiate the decompression process and briquetted sample removal. Amazing fast ram travel speed expedites briquetting samples for XRF analysis.

Threaded arbor with knurled knob adapts to any conventional die height. This feature enables controlling the volumetric sample capacity of the die for standardizing sample briquette thickness.

Self-centering and self-aligning die feature integrated in the ram platform accepts optionally available 32, 35, 40 and 45 mm evacuable [stainless steel dies](#). Small compact design allows counter-top installations. Illuminated working chamber (on some models) improves visibility.

### FEATURES

- Exceptionally fast ram response time
- Self-centers Chemplex 32, 35, 40 and 45 mm dies on innovative designed platen
- Simple two button operation; ram up and ram down
- High visibility analog gauge indicates tons in one ton increments up to 30 tons
- Adjustable knurled-knob arbor enables uniformly thick sample briquettes by compensating for variable density differences
- Quiet counter top operation
- Functions best with recommended use of [PelletCups®](#) tapered briquetting cups
- Illuminated working chamber on some models

### SPECIFICATIONS

Dimensions: 14.5" deep x 17.5" wide x 17" high (37 cm x 45 cm x 43 cm)  
Weight: 210 lbs (94.5 kg)



Simple Two Button Operation  
Ram Up and Ram Down

Cat. No.	Description	Optionally Available Die Sets
4300-115	Semi-Automatic 30 Ton SpectroPress;® 115Vac/60Hz; single phase	4030 (32mm), 4038 (35mm),
4300-230	Semi-Automatic 30 Ton SpectroPress;® 230Vac/50Hz; single phase	4040 (40mm), 4047 (45mm)

**SpectroPress<sup>®</sup> Manual 12 Ton Pellet Press**  
FOR XRF and IR BRIQUETTING

- Sample Cups and Accessories
- Thin-Film Sample Supports
- Grinding Machines and Accessories
- Briquetting Presses and Accessories
- Grinding/Briquetting Additives
- Fusion Machines and Accessories
- Standards and XRF/XRD Chemical Kits



Unique platen accepts, self-aligns and self-centers all Chemplex<sup>®</sup> optionally available die sizes

Compact contemporary two post designed manual SpectroPress<sup>®</sup> model delivers 12 tons of force. Large accessible area facilitates fast and easy die removal and reinsertion.

Accepts Chemplex<sup>®</sup> annealed [stainless steel die](#) sets optionally available for producing 32, 35, 40 and 45 mm diameter XRF sample briquettes and 13 mm diameter sample for IR applications.

With the exception of the 13 mm die size, the stainless steel dies are designed to accept Chemplex<sup>®</sup> compressible tapered aluminum [PelletCups<sup>®</sup>](#) powdered sample briquetting cups.

Long 20" (51 cm) pumping handle with rubber grip facilitates pumping. Pressure release control rapidly retracts ram. Analog gauge indicates 0 to 12 tons in 0.4 ton increments. Four 17/32" (0.531") diameters through holes with 7/8" diameter x 1/2" deep counterbores in each corner are provided to safely secure the press in position.

The platen, or die platform, is uniquely designed to accept Chemplex<sup>®</sup> 13, 32, 35, 40 and 45 mm evacuable stainless steel die sets. The platen incorporates a series of stepped counter bores that serve to accommodate, self-align, self-center and secure the respective die sizes in position. It is important that the die is placed completely within the confines of a counterbore. The use and applications of another die brand presents the potential possibility of misfit, endangerment and damage to the machine.

**Specifications**

Dimensions: 14" wide x 12" deep; x 20" high (36 x 31 x 51 cm)  
Weight: 102 lbs (46 kg)

**Ordering Information**

Cat. No.	Description	Optionally Available Die Sets
4312	Manual 12 Ton Force SpectroPress <sup>®</sup> Model	4013 (13 mm), 4030 (32mm), 4038 (35mm), 4040 (40mm), and 4047 (45mm)

- Sample Cups and Accessories
- Thin-Film Sample Supports
- Grinding Machines and Accessories
- Briquetting Presses and Accessories
- Grinding/Briquetting Additives
- Fusion Machines and Accessories
- Standards and XRF/XRD Chemical Kits

## XRF Pellet Press Stainless Steel Die Sets



Chemplex die sets are available in all standard diameter sizes for XRF briquette formations. For applications in an evacuated environment, optional models with fluted side-arms and related "O" ring seals are available. A 13 mm die is also available for IR sample preparations.

Chemplex® die sets are fabricated "in-house" from a quality grade of stainless steel. They are annealed to a Rockwell "C" hardness of at least 60 to minimize or eliminate abrasion and scoring from contact with very hard sample particles.

Close tolerance precision grinding ensures perfect dimensional compatibility with Chemplex® stainless steel and tungsten carbide pellets and [PelletCups](#)® compressible tapered aluminum briquetting cups. Each die set is labeled with the maximum load; do not exceed it.

For applications requiring briquetting in an evacuated environment, die sets are optionally available with a fluted side-arm and appropriate "O" ring seals for connection to a vacuum source.

**Chemplex® compressible tapered aluminum PelletCups® are strongly recommended for use with Chemplex® briquetting die sets and all semi and automatic SpectroPress® pellet presses.**

### SPECIFICATIONS AND ORDERING INFORMATION

#### Standard Size Stainless Steel Die Sets Without Fluted Side-Arms

Cat. No.	Description	Max. Force Rating
4013-55	Produces 0.51" (13mm) IR Sample Pellets	8 tons
4030-55	Produces 1.25" (32mm) XRF Sample Pellets	50 tons
4038-55	Produces 1.38" (35mm) XRF Sample Pellets	70 tons
4040-55	Produces 1.57" (40mm) XRF Sample Pellets	85 tons
4047-55	Produces 1.77" (45mm) XRF Sample Pellets	85 tons

#### Optionally Available Standard Size Stainless Steel Die Sets with Fluted Side Arms

Cat. No.	Description	Max. Force Rating
4013	Produces 0.51" (13mm) IR Sample Pellets	8 tons
4030	Produces 1.25" (32mm) XRF Sample Pellets	50 tons
4038	Produces 1.38" (35mm) XRF Sample Pellets	70 tons
4040	Produces 1.57" (40mm) XRF Sample Pellets	85 tons
4047	Produces 1.77" (45mm) XRF Sample Pellets	85 tons

#### Stainless Steel and Tungsten Carbide Replacement Pellets

Formed Pellet Diameter	Stainless Steel Catalog Number	Tungsten Carbide Catalog Number
13mm (0.51")	4033	N/A
32mm (1.25")	4050	4035
35mm (1.38")	4055	4037
40mm (1.57")	4060	4045
45mm (1.77")	4065	4048

**IMPORTANT:** Chemplex® manufactured pellet presses, briquetting dies and compressible tapered aluminum briquetting PelletCups® are designed for compatibility in relation to each other. Chemplex® assumes no responsibility for the incompatibility or performance of seemingly similar items used in conjunction with Chemplex® manufactured products and any damages.

© SpectroPress, PelletCups, and Chemplex are registered trademarks of Chemplex Industries, Inc.

™ PlastiCups is a trademark of Chemplex Industries, Inc.

## PelletCups<sup>®</sup> Powdered Sample Compactors

- Sample Cups and Accessories
- Thin-Film Sample Supports
- Grinding Machines and Accessories
- Briquetting Presses and Accessories
- Grinding/Briquetting Additives
- Fusion Machines and Accessories
- Standards and XRF/XRD Chemical Kits



Available in 32, 35, 40 and 45 mm diameters corresponding to Chemplex<sup>®</sup> compressible tapered aluminum PelletCups<sup>®</sup> briquetting cups

Variations in powdered sample densities frequently present difficulty in forming sturdy briquettes to a uniform standard thickness. Sample briquettes are generally wafer thin, delicate to handle and potentially subject to breakage during analysis. Although briquetting in aluminum PelletCups<sup>®</sup> adds physical support it can not compensate for the limited sample mass for thicker pellets. In response, Chemplex<sup>®</sup> offers a series of hand-held devices to maximally compact powdered samples in sample cups prior to final briquetting.

The PelletCups<sup>®</sup> Powdered Sample Compactors are self-aligning, self-centering hand-held devices that serve to tamp a powdered sample in a compressible aluminum tapered sample cup in progressive stages to ensure full compaction before final briquetting in a hydraulic press. Manufactured from quality stainless steel and precision honed to correspond to the dimensions and close tolerances of Chemplex<sup>®</sup> compressible aluminum tapered PelletCups<sup>®</sup> and annealed stainless steel die sets.



Low Density Powders Tend to Overflow



Yield Wafer-Thin Delicate Briquettes



Pre-Packed Samples Form Uniformly Standard Briquettes

### Specifications and Ordering Information

Cat. No.	Description
2532	PelletCups <sup>®</sup> Powdered Sample Compactor for 32 mm Pellets
2535	PelletCups <sup>®</sup> Powdered Sample Compactor for 35 mm Pellets
2540	PelletCups <sup>®</sup> Powdered Sample Compactor for 40 mm Pellets
2545	PelletCups <sup>®</sup> Powdered Sample Compactor for 45 mm Pellets

## SpectroPellet® Protective Pellet Die Film

- Sample Cups and Accessories
- Thin-Film Sample Supports
- Grinding Machines and Accessories
- Briquetting Presses and Accessories**
- Grinding/Briquetting Additives
- Fusion Machines and Accessories
- Standards and XRF/XRD Chemical Kits



Available for 32, 35 and 40 mm dies

Some powdered sample materials exhibit tendencies to adhere to the pellet die surface during the briquetting operation. This condition frequently results in repeated attempts to form a satisfactory sample briquette with increasing potential threats of cross contamination and elaborate time consuming clean ups. A novel approach to resolving this problem is by using Chemplex® SpectroPellet® Film in precut circles.

SpectroPellet® Film is characterized with a low coefficient of sample adhesion and resistant to puncture. By simply inserting a SpectroPellet® Film precut circle between the die pellet and powdered sample substance, a barrier is formed that protects the contact surfaces of the pellet die and briquetted sample. The unique combination of qualities of SpectroPellet® Film maintains the briquetted sample material and pellet die surfaces intact by eliminating sample particle adhesion; pellet die clean ups are greatly facilitated.

Each precut SpectroPellet® Film circle is supported on a paper carrier frame for convenience of handling and application. Available in three different sizes for use with: 32, 35 and 40 mm diameter dies.

### FAST, CONVENIENT AND SIMPLE TO USE

1. Place a small droplet of ordinary methyl, ethyl or isobutyl alcohol on the center of a clean surface of a die pellet. The alcohol serves as a temporary adhesive for attaching a SpectroPellet® Film.
2. Transfer a SpectroPellet® Film to the die pellet by first sliding a small amount of the precut circle from the carrier frame starting from one point of the pellet and across to the opposite end. Completely remove the carrier frame and use as a final centering aid of the precut film circle.
3. Repeat the procedure to the surface of the second die pellet (or integrated die cap) and briquette the sample in the usual manner. The SpectroPellet® Film is easily removed and clean ups are minimal.



### SPECIFICATIONS AND ORDERING INFORMATION

Cat. No.	Nominal Diameter Of Die	Die Set Catalog Number Compatibility	Number of Precut Circles per Pkg.
7032	1.25" (32 mm)	4030 Evacuatable Die Set and 43032 Integrated Die Set	500
7035	1.375" (35 mm)	4038 Evacuatable Die Set and 43035 Integrated Die Set	500
7040	1.57" (40 mm)	4040 Evacuatable Die Set and 43040 Integrated Die Set	500

**PelletAid™ Sample Pellet Release Agent and Die Conditioner**

- Sample Cups and Accessories
- Thin-Film Sample Supports
- Grinding Machines and Accessories
- Briquetting Presses and Accessories
- Grinding/Briquetting Additives
- Fusion Machines and Accessories
- Standards and XRF/XRD Chemical Kits



A simple “dusting” application to the metal pellet included with a die set prevents the sample from sticking. Consisting of a lubricious organic substance, PelletAid™ sample pellet release agent and die conditioner does not introduce unwanted analyte-lines of significant detection.

When sparingly applied to the inside walls of a die set, movement of the pellets and plunger is greatly facilitated. PelletAid™ die conditioner has an unusual affinity to adhere to metal components and serves as a dry focused lubricant.

**CHEMICAL CONSTITUENTS**

C	H	O	Na
70.6%	11.5%	10.4%	7.5%

**SPECIFICATIONS AND ORDERING INFORMATION**

Cat. No.	Description
875	PelletAid™ Sample Release/Die Conditioner Agent

Refer to [SpectroPellet® Film](#) to Protect Die Pellet Surfaces, Prevent Sample Adhesion and Facilitate Clean-Ups

**Chemplex**<sup>®</sup> INDUSTRIES, INC.

2820 SW 42<sup>nd</sup> Ave. Palm City, Fl. 34990-5573, USA  
Continental USA Toll Free: (800) 4-CHEMPLEX Phone: (772) 283-2700 Fax: (772) 283-2774  
Email: [sales@chemplex.com](mailto:sales@chemplex.com) On Line Sales: <http://www.chemplex.com>

- Sample Cups and Accessories
- Thin-Film Sample Supports
- Grinding Machines and Accessories
- Briquetting Presses and Accessories**
- Grinding/Briquetting Additives
- Fusion Machines and Accessories
- Standards and XRF/XRD Chemical Kits

## PelletCups® Compressible Tapered Aluminum XRF Briquetting Cups



**Tapered-Walled, Aluminum PelletCups® Briquetting Cups**



**Tapered-Walled, 13 mm Aluminum PelletCups® Briquetting Cups**

Transform powdered samples into firm durable solid briquettes protected on all sides excepting for the surface to be analyzed. Minimizes potential hazards of breakage, easy to handle and spill over into briquetting dies. Simply fill a PelletCups® briquetting cup with the powdered sample substance, place into a Chemplex® die and briquette in usual manner.

**Tapered-Walled, Aluminum PelletCups® Briquetting Cups** is a Chemplex® innovation and represent the most popular sample cups for briquetting powdered samples for XRF analysis. The unique taper tends to reduce cracking and fissure development. Very close outside diameter tolerance minimizes sample particles spilling over and becoming entrapped in between the inside walls of the die and briquetting cups. Powdered samples gently float down into a Chemplex® standard size die set on a cushion of entrapped air further reducing the likelihood of spillage.

**Tapered-Walled, PlastiCup™ Briquetting Cups** are similar to their "ORIGINAL" aluminum counterparts excepting fabricated of a specialty plastic, shallower and accommodating less sample volume. Lubricious plastic quality helps extend die life during ejection from the die.

**Tapered-Walled, 13 mm Aluminum PelletCups® Briquetting Cups** are incorporated in the Chemplex standard product line for use in conjunction with standard 13 mm diameter briquetting die sets. The main use of 13 mm diameter samples is traditionally associated with IR analytical applications that heretofore require a backing agent such as boric acid, X-Ray Mix® or SpectroBlend® powders to provide mass to the sample substance. By completely encasing the sample material within the confines of the PelletCups®, the briquetted samples are substantially more resistant to damage through handling and conducive to preservation for future referral.

**Tapered Compressible Aluminum PelletCups®** are strongly recommended for use with Chemplex® Precision Fabricated and Annealed Briquetting Die Sets and all SpectroPress® Models

### SPECIFICATIONS AND ORDERING

#### Compressible Tapered-Walled Aluminum PelletCups® Briquetting Cups

Cat. No.	Outside Diameter	Height	PelletCups/Pkg
513	0.49" (12.5 mm)	0.36" (9.0 mm)	250
505	1.22" (31 mm)	0.31" (7.9 mm)	1000
535	1.36" (34.6 mm)	0.37" (9.3 mm)	600
545	1.57" (39.8 mm)	0.36" (9.1 mm)	600
547	1.76" (44.7 mm)	0.36" (9.11 mm)	600

#### Compressible Tapered-Walled PlastiCup™ Briquetting Cups

Cat. No.	Outside Diameter	Height	PelletCups/Pkg
552	1.22" (31.0 mm)	0.25" (6.4 mm)	500
553	1.35" (34.3 mm)	0.25" (6.4 mm)	500
554	1.56" (39.7mm)	0.25" (6.4 mm)	500

- Sample Cups and Accessories
- Thin-Film Sample Supports
- Grinding Machines and Accessories
- Briquetting Presses and Accessories
- Grinding/Briquetting Additives
- Fusion Machines and Accessories
- Standards and XRF/XRD Chemical Kits

## XRF Grinding, Blending and Briquetting Additives



Grinding/Briquetting Additives  
Supplied in Powder and Pre-Weighed Tablets

Most powdered sample substances are considered multi-phased or compositionally complex. They are comprised of individual particles or crystal phases frequently dissimilar in composition, density, hardness, configuration, size and distribution. Each particle tends to behave as a separate entity from its surrounding constituents. Chemplex® grinding and briquetting additives are formulated to aid in the grinding and briquetting process by reducing particles to a uniform size and distribution forming a homogeneous sample blend for XRF analysis. Under briquetting pressure, the powdered samples are transformed into "plasticized" pellets with smooth unblemished surfaces resistant to inadvertent chipping or flaking apart. Samples may be saved for future referral.

### PREPARING SAMPLES

In preparing powdered samples requiring a grinding or briquetting additive, it is most advantageous to use the least amount of additive to minimize the effects of dilution unless the use of the additive is for dilution purposes.

As a starting point, use 1.0 to 2.5 wt % additive of the sample weight, e.g. 0.1 to 0.25 gm additive, to 10 gm sample. Adjust the amount of additive until the desired results are obtained. Alternatively, the additive weight may be held constant and the sample weight quantity varied for applications that will be utilizing the convenience of pre-weighed tablets. To maintain compatibility, standards should be similarly prepared.

### GRINDING/BRIQUETTING ADDITIVE PROFILES

Additive	Chemical Composition
X-Ray Mix®	48.7% C, 42.6% O, 8.1% H, 0.6% B
SpectroBlend®	81.0% C, 2.9% O, 13.5% H, 2.6% N
Boric Acid	77.6% O, 4.9% H, 17.5% B

Note: Some additives may reportedly contain trace elements that may potentially interfere with a given analysis. It is suggested that a "Blank" is run to evaluate the presence and interference level prior to an analytical investigation.

### TYPICAL APPLICATIONS

Cement Raw Mix Sinters Slags Catalysts Ores Refractories Fertilizers Soil Phosphate Rock Oxides Alumina Bauxite Carbonates  
Silicates Organics Inorganics And many other types of sample substances exhibiting difficulty in particle size reduction, distribution and briquetting

Additive	Prominent Characteristics
<b>X-Ray Mix®</b>	General purpose grinding agent. Balanced for abrasiveness and lubricity to aid in grinding dissimilar particles of moderate hardness for relatively short times. Highly "plasticizes" and firmly bonds samples together under briquetting pressure. Available in pre-weighed tablets for ease of dispensing.
<b>SpectroBlend®</b>	A 44µ powder well suited for blending and as a diluent for high concentrations. Well balanced with abrasive and lubricious constituents for grinding most sample materials emphasizing difficult-to-process samples requiring long grinding cycles in metallic comminution vials or dishes. Resistant to degradation by thermal and irradiation exposure. Samples have "plasticized" surfaces. Available in bulk powder and ½ gm pre-weighed tablets for ease of dispensing.
<b>Boric Acid</b>	Abrasive substance for processing samples with strong re-welding tendencies. Sample pellets are fair to moderately bond together. Frequently used in conjunction with other additives to impart increased abrasiveness to the grinding process.

### SPECIFICATIONS AND ORDERING INFORMATION

Cat. No.	Description
600	X-Ray Mix® Powder; 1 lb/btl (454 gm)
625	X-Ray Mix® ¼ gm Tablets; 250 tablets/btl
650	X-Ray Mix® ½ gm Tablets; 500 tablets/btl
660	SpectroBlend® 44µ Powder; 1 lb/btl (454 gm)
690	SpectroBlend® ½ gm Tablets; 500 tablets/btl
750	Boric Acid ½ gm Tablets; 1000 tablets/btl

**Liquid-Binder<sup>®</sup> Aqueous Grinding and Briquetting Additive**

- Sample Cups and Accessories
- Thin-Film Sample Supports
- Grinding Machines and Accessories
- Briquetting Presses and Accessories
- Grinding/Briquetting Additives**
- Fusion Machines and Accessories
- Standards and XRF/XRD Chemical Kits



For powdered samples deficient in briquette forming constituents and dilution with an additive presents a problem, Liquid-Binder<sup>®</sup> grinding/briquetting additive offers an alternative. Blend a small amount Liquid-Binder<sup>®</sup> Aqueous Grinding and Briquetting Additive with the sample until homogeneous slurry develops. Evaporate the carrier and de-agglomerate the sample by grinding. Liquid-Binder<sup>®</sup> grinding/briquetting additive coats each sample particle with a completely organic polymeric binding ingredient that tenaciously holds it together. Form into a briquette in the usual manner. Sample pellet is firm, extremely hard and resistant to breakage. 1 cc Liquid-Binder grinding/briquetting additive contains 100 mg polymeric ingredient,  $(C_6H_9ON)_n$ , in methylene chloride solvent.

**SPECIFICATIONS AND ORDERING INFORMATION**

Catalog No.	Description
800	Liquid-Binder <sup>®</sup> ; 1 pt (480 cc)

<sup>®</sup>Liquid-Binder and Chemplex are registered trademarks of Chemplex Industries, Inc.

Notice: Liquid-Binder<sup>®</sup> contains ethylene chloride. Use in a well-ventilated area, avoid inhalation and contact. Send for MSDS prior to purchase.

**Chemplex<sup>®</sup> INDUSTRIES, INC.**

2820 SW 42<sup>nd</sup> Avenue  
Palm City, Fl. 34990-5573, USA

Continental USA Toll Free: (800) 4-CHEMPLEX  
Phone: (772) 283-2700  
Fax: (772) 283-2774  
Email: [sales@chemplex.com](mailto:sales@chemplex.com)

**On Line Sales:** <http://www.chemplex.com>

## Powdered Briquetted Sample Pod Storage Kits

Sample Cups  
and Accessories

Thin-Film  
Sample Supports

Grinding Machines  
and Accessories

Briquetting Presses  
and Accessories

Grinding/Briquetting  
Additives

Fusion Machines  
and Accessories

Standards and  
XRF/XRD Chemical Kits



Pod Illustrated in Closed Position



Pod Illustrated in Open Position  
Exposing Thin-Film Membrane for  
Sample Placement



Sample Storage Pod Kits for  
Accommodating 10 or 5 Individual Pods

Chemplex® Industries, Inc. has developed an innovative sample storage system that safely catalogs, stores and protects powdered briquetted samples and standards against shock, abrasion and breakage.

A uniquely designed clear rigid plastic pod consists of two equal halves with soft clear polymer thin-films integrated on the inside of each half. The powdered briquetted sample is simply placed on the thin-film membrane of either half of the pod and the two pods are snapped to form an effective seal. The sample is totally encased between the two membranes and remains in suspension within the center of the closed pod without physical contact with the inside walls of the pod rendering the sample full immunity against shock, abrasion or breakage.

Sample Pod Storage Kits are pre-assembled with 5 or 10 pods in a white box with a lid. Each pod accommodates up to 45 mm diameter samples. The entire white outer layer is receptive to identifying the contents and other necessary information for future referral and easy retrieval. Replacement or spare sample pods are also supplied individually.

The most effective and economic storage system for categorizing, preserving, protecting, transporting; powdered briquetted samples, metallographic specimens, precious gems, optical glasses, delicate l'art objets and many other types of specimens and items.

### Specifications and Ordering Information

Cat. No.	Description
2030-10	Sample Pod Storage Kits with Ten Sample Pods
2030-5	Sample Pod Storage Kits with Five Sample Pods
2030-1	Replacement and Spare Sample Pods

**Chemplex® INDUSTRIES, INC.**

2820 SW 42<sup>nd</sup> Avenue, Palm City, Fl. 34990-5573, USA

Continental USA Toll Free: (800) 4-CHEMPLEX

Phone: (772) 283-2700

Fax: (772) 283-2774

Email: [sales@chemplex.com](mailto:sales@chemplex.com)

On Line Sales: <http://www.chemplex.com>

## XRD Mineralogy Set

- Sample Cups and Accessories
- Thin-Film Sample Supports
- Grinding Machines and Accessories
- Briquetting Presses and Accessories
- Grinding/Briquetting Additives
- Fusion Machines and Accessories
- Standards and XRF/XRD Chemical Kits



The XRD Mineralogy Set is a collection of 50 different mineralogical substances; most are rare, for non-destructive material characterization, analytical identification and comparison studies with diversified instrumentation inclusive of refractive index, birefringence microscopy and x-ray diffraction. Each mineral is initially hand selected for relatively high concentration content, comminuted to a uniform particle size of 44 $\mu$  (-325 mesh size) and blended to ensure uniform representation.

Approximately 1/2 cc of each of the listed substances is contained in a labeled glass vial sealed with a polycone screw cap. The vials are organized in a protective polyfoam block and packaged in an attractive lockable wood case. The inside lid contains a reference chart alpha-numerically keyed to the mineral vial positions for easy identification and retrieval.

### Table of Minerals Content

Albite	Cassiterite	Lepidolite	Pumice	Spodumene
Amazonite	Celestite	Microline	Pyroxdenite	Tetrahedrite
Anhydrite	Cryolite	Monzonite	Quartz	Titanite
Apatite	Epidote	Nepheline	Rhodochrosite	Topaz
Aragonite	Fluorite	Obsidian	Rutile	Tourmaline
Azurite	Glaucanite	Olivine	Scheelite	Tremolite
Barite	Grossular	Opal	Serpentine	Vesuvianite
Beryl	Gypsum	Orpiment	Siderite	Wollastonite
Biotite	Hornblende	Parthite	Sodalite	Zincite
Calcite	Labradorite	Prehnite	Sphalerite	Zircon

### Specifications and Ordering Information

Catalog Number	Description	Dimensions
3000	XRD Mineralogy Set	6.5" x 4.5 x 2.5"

NOTE: The constituent minerals are hand selected, washed to remove any obvious superficial extraneous matter and comminuted to particle size as indicated above. No further processing is performed. Purchase is made with the understanding that these are not intended to represent replacement substances for primary standards.

**SpectroStandards® XRF Reference Materials Preparation Kit**

- Sample Cups and Accessories
- Thin-Film Sample Supports
- Grinding Machines and Accessories
- Briquetting Presses and Accessories
- Grinding/Briquetting Additives
- Fusion Machines and Accessories
- Standards and XRF/XRD Chemical Kits



In the absence of readily available reference substances, the SpectroStandards® XRF Reference Materials Preparation Kit offers an alternate choice in accommodating infrequent or “out of the ordinary” sample unknowns. The unique assemblage of assorted compounds contains 50 elements to prepare “in-lab” reference materials for single or multiple elemental analyses.

The method involves gravimetric dilution of a compound with a diluent, such as [SpectroBlend®](#) 44µ Powder, Cat. No: 660, to develop a weight percent concentration value of the element of interest. Two sample vials of SpectroBlend® Powder each containing 6 gm are included with each Kit. Successive dilution preparations serve in establishing a linear correlation of the concentrations and analyte-line intensities against which the unknown sample is referred to and assigned a concentration value. Although this methodology suffices in many instances, it is not intended as a replacement for standardization with certified materials of similar matrices for exacting results. It serves its application in situations where time, primary standard availability and frequency of sample submittals represent uncertainties and advance preparedness is a current option with a SpectroStandards® Reference Standard Kit.

Instructions are included for dilution of each compound to a desired element concentration followed by thorough blending with the diluent to ensure homogeneity. After blending, the diluted mixture is usable in “loose powder” form by transferring it to a sample cup with a thin-film attached or in a tapered pellet cup for briquette formation. Reference material briquettes have additional applications during initial instrument installations, for optimizing and monitoring instrument performance and drift.

**SpectroStandards® XRF Reference Materials Preparation Kit Chemical Listing**

<b>Ag</b> Ag <sub>2</sub> O	<b>Al</b> Al <sub>2</sub> O <sub>3</sub>	<b>As</b> As <sub>2</sub> O <sub>3</sub>	<b>Ba</b> BaHPO <sub>4</sub>	<b>Be</b> BeO	<b>Bi</b> Bi <sub>2</sub> O <sub>3</sub>	<b>Ca</b> CaO	<b>Ca</b> CdO	<b>Ce</b> CeO <sub>2</sub>	<b>Co</b> Co <sub>3</sub> O <sub>4</sub>
<b>Cr</b> Cr <sub>2</sub> O <sub>3</sub>	<b>Cs</b> CsNO <sub>3</sub>	<b>Cu</b> CuO	<b>Fe</b> Fe <sub>2</sub> O <sub>3</sub>	<b>Ga</b> Ga <sub>2</sub> O <sub>3</sub>	<b>Ge</b> GeO <sub>2</sub>	<b>Gd</b> Gd <sub>2</sub> O <sub>3</sub>	<b>Hf</b> HfO <sub>2</sub>	<b>Hg</b> HgO	<b>In</b> In <sub>2</sub> O <sub>3</sub>
<b>I</b> I <sub>2</sub> O <sub>5</sub>	<b>K</b> K <sub>2</sub> CO <sub>3</sub>	<b>La</b> La <sub>2</sub> O <sub>3</sub>	<b>F</b> LiF	<b>Mg</b> MgO	<b>Mn</b> MnO <sub>2</sub>	<b>Mo</b> MoO <sub>3</sub>	<b>Na</b> NaCl	<b>Nb</b> Nb <sub>2</sub> O <sub>5</sub>	<b>P</b> NH <sub>4</sub> H <sub>2</sub> PO <sub>4</sub>
<b>Sc</b> Sc <sub>2</sub> O <sub>3</sub>	<b>Pb</b> PbO	<b>Rb</b> RbCl	<b>S</b>	<b>Sb</b> Sb <sub>2</sub> O <sub>3</sub>	<b>Ni</b> NiO	<b>Se</b> SeO <sub>2</sub>	<b>Si</b> SiO <sub>2</sub>	<b>Sn</b> SnO <sub>2</sub>	<b>Sr</b> SrCO <sub>3</sub>
<b>Ta</b> Ta <sub>2</sub> O <sub>3</sub>	<b>Te</b> TeO <sub>2</sub>	<b>Th</b> ThO <sub>2</sub>	<b>Ti</b> TiO <sub>2</sub>	<b>Tl</b> Tl <sub>2</sub> O <sub>3</sub>	<b>Tm</b> Tm <sub>2</sub> O <sub>3</sub>	<b>V</b> V <sub>2</sub> O <sub>5</sub>	<b>W</b> WO <sub>3</sub>	<b>Zn</b> ZnO	<b>Zr</b> ZrO <sub>2</sub>

**Specifications and Ordering Information**

Cat. No.	Description
6700	SpectroStandards® XRF Reference Materials Preparation Kit

Note: Chemplex Industries, Inc. reserves the right to substitute compounds and purities depending upon availability without advance notifications. This product is intended for relative comparison studies and not suggested for use as primary standards. The judicious use and applications of this product resides solely with the purchaser and/or user.

® SpectroStandards, SpectroBlend and Chemplex are registered trademarks of Chemplex Industries, Inc.

Sample Cups  
and Accessories

Thin-Film  
Sample Supports

Grinding Machines  
and Accessories

Briquetting Presses  
and Accessories

Grinding/Briquetting  
Additives

Fusion Machines  
and Accessories

Standards and  
XRF/XRD Chemical Kits

## **SpectroCertified<sup>®</sup> Polysulfide SpectroStandards<sup>®</sup> Calibration, Quality Control and Monitoring Formulations**



Polysulfide SpectroStandards<sup>®</sup> formulations contain the necessary physical and chemical Properties for XRF spectrochemically analyzing innumerable types of non-aqueous sample substances:

### **Polysulfide Formulations**

**Purity**  
**Reliability**  
**Low Volatility**  
**Long Shelf Life**  
**Consistency**  
**Storability at Room Temperature**  
**Stability at High X-Ray Tube Wattage**  
**Miscibility with Petroleum Products**

Chemplex calibration polysulfide SpectroStandards<sup>®</sup> are formulated from refined high-purity, sulfur-free, low viscosity starting materials. They are blended by serial mass dilution to 4 significant places with a petroleum base and certified by reference to NIST standard reference materials. Appropriate Certificates of Analysis accompany each SpectroStandard. The formulated polysulfides are miscible with lubricating and mineral oils, diesel and ultra clean fuels, high weight percent sulfur content in crude and residual oils; and low vapor pressure that inhibits thin-film sample support diffusion. Polysulfide is characterized with a long shelf life and stability at room temperature.

Polysulfide calibration standards are in compliance with recent revisions of ASTM D2622 and D4294 methods that indicate the acceptable use of polysulfide oil standards.

- Sample Cups and Accessories
- Thin-Film Sample Supports
- Grinding Machines and Accessories
- Briquetting Presses and Accessories
- Grinding/Briquetting Additives
- Fusion Machines and Accessories
- Standards and XRF/XRD Chemical Kits

**SpectroCertified® Polysulfide SpectroStandards® Calibration, Quality Control and Monitoring Formulations**  
**ORDERING AND PRODUCT SPECIFICATIONS INFORMATION**

**Calibration SpectroStandards®, Single Bottle Units**

**PPM Sulfur Concentration Units**

Concentration Range: 0 to 1000 PPM Sulfur  
Quantity: 100 ml/bottle



Cat. No.	PPM S
70-30000	Blank
70-30005	5
70-30010	10
70-30025	25
70-30050	50
70-30100	100
70-30250	250
70-30500	500
70-30750	750
70-31000	1000

**Weight Percent Sulfur Concentration Units**

Concentration Range: 0.1 to 5 Wt. % Sulfur  
Quantity: 50 ml/bottle



Cat. No.	Wt. % S
70-41001	0.1
70-41005	0.5
70-41010	1.0
70-41020	2.0
70-41030	3.0
70-41040	4.0
70-41050	5.0

**Calibration SpectroStandards® Sets**

**PPM Sulfur Concentration Unit Sets**

Concentration Range: 0 to 1000 PPM Sulfur  
Quantity: 100 ml/bottle

Cat. No.	PPM SULFUR													
	0.0	1.0	2.5	5.0	10	25	50	75	100	250	500	750	1000	
70-51213	X	X	X	X	X	X	X	X	X	X	X	X	X	X
70-51306	X								X	X	X	X	X	X
70-51406	X				X	X	X		X	X				
70-51506	X				X		X		X	X	X			

**Quality Control and Drift SpectroStandards® Formulations**

Quality control and drift standards are used to adjust for any changes in instrument sensitivity over a given term of operation, as determined by each laboratory, and to reduce or eliminate the need to effect time consuming and costly recalibrations. High purity polysulfide formulations have long shelf lives and are resistant to degradation. They are formulated from a concentrate and provided in convenient one liter size bottles to ensure uniform consistency and dispensing freshly prepared quantities as required. Drift corrections are generally performed whenever the quality control data moves beyond acceptable limits. With multiple instruments, Quality Control and Drift standards are ideally applicable to multiple x-ray instrument laboratories, inter-laboratory and plant installations for uniformity of performance and cost effectiveness by drawing from liter size bottle quantities.

**PPM Sulfur Concentration Units**

Concentration Range: 5 to 1000 PPM Sulfur.  
Quantity: 1liter/bottle



Cat. No.	PPM S
70-60005	5
70-60010	10
70-60025	25
70-60100	100
70-60250	250
70-60500	500
70-61000	1000

**Weight Percent Sulfur Concentration Units**

Concentration Range: 2, 3 and 5 Wt. % Sulfur.  
Quantity: 100 ml/bottle



Cat No	Wt. % S
70-81002	2
70-81003	3
70-81005	5

**Quality Control and Drift Standard Blank**

Quantity: 1liter/bottle

Order Catalog Number: **70-10000**



## **SpectroCertified<sup>®</sup> Standard Reference Materials and SpectroStandards<sup>®</sup> Quality Formulations**

Sample Cups and Accessories

Thin-Film Sample Supports

Grinding Machines and Accessories

Briquetting Presses and Accessories

Grinding/Briquetting Additives

Fusion Machines and Accessories

**Standards and XRF/XRD Chemical Kits**

SpectroStandards<sup>®</sup> standard reference materials are specially formulated in accordance with world recognized methodologies and to comply with the various governmental and regulatory agency requirements whenever feasible. SpectroCertified<sup>®</sup> standard reference materials are accompanied with Certificates of Analysis indicating traceability to applicable methodologies, standard reference sources and validity terms together with relative degrees of uncertainty.



### **PRODUCT DIRECTORY**

[Click to Access](#)

[Nomenclature \(Understanding the Assignment of Catalog Numbers\)](#)



[Biodiesel Testing Standards; ASTM D5453, D6584, D2887; DIN EN 14105, 14538, 14214, 14103, 14110](#)



[Sulfur in Mineral, Diesel Fuels and Synthetic Diesel Fuel Matrices; Tables 1, 2, 3, 4.](#)



[Sulfur in Residual and Diesel Fuel; Low to High Sulfur \(EPA Methods\); Sulfur and Chlorine in Waste Oil; Tables 5, 6, 7, 8, 9, 10, 11.](#)



[Sulfur and Metals \(Fe, Ni and V\) Standards in Mineral and Residual Oil Matrices; Tables 12 to 15.](#)



[Quick Reference Guide for Lubricating Oil Standard Specifications \(Ca, P, S, Zn, Ba, Cl, Mg & Cu\)](#)



[Multi-Element Wear Metal Organo-Metallic Standards \(Ag, Al, B, Ba, Ca, Cd, Cr, Cu, Fe, K, Mg, Mo, Na, Ni, P, Pb, Sb, Si, Sn, Ti, V & Zn\); Unsulfonated sulfur-free and sulfonated matrices; Tables 29, 30, 31, 32, 33, 34, 35.](#)



[Diluted Single-Element Organo-Metallic Oil Standards; Table 36.](#)



[Concentrated Single-Element Organo-Metallic Oil Standards in Lubricating Oil Matrices; Table 37.](#)



[Single-Element Sulfur Concentrations in Mineral, Diesel and Residual Oils; Table 38, 39, 40, 41.](#)



## Understanding Catalog Number Assignments

Sample Cups and Accessories
Thin-Film Sample Supports
Grinding Machines and Accessories
Briquetting Presses and Accessories
Grinding/Briquetting Additives
Fusion Machines and Accessories
<b>Standards and XRF/XRD Chemical Kits</b>

The contained product assignments are based on using almost self-descriptive alpha-numeric combinations of the element of primary interest, the matrix and the number of individual standards comprising a complete set. The purpose of this explanation is to assist the reader in interpreting the product catalog number thereby reducing or eliminating the potential possibility of introducing errors in the ordering process and most importantly to receive the items requested without undue delay.

The products of similarity have also been assembled in table format with each appearing in their respective sections for ease of location and reference further simplifying the selection process.

The product prefix is generally in alpha format that infers the classification of the product matrix. The characters following the alpha format may also be in alpha format that serves to define the product in greater detail. The sets of alpha characters are generally followed by a numeric suffix that relates to the number of individual standards comprising a complete set.

The following will be helpful in deciphering and understanding the nomenclature.

### Alpha-Strings:

The Alpha-strings denote the type of matrix.

- MO** = Mineral Oil
- ULSD** = Ultra Low Sulfur in Diesel
- DF** = Diesel Fuel
- RO** = Residual Oil
- EPA** = a method complying with the Environmental Protection Agency
- WO** = Waste Oil
- NVMO and FNVMO** = Nickel and Vanadium and Iron (Ferrous), nickel and vanadium in Mineral Oil
- NVRO and FNVRO** = Nickel and Vanadium and Iron (Ferrous), nickel and vanadium Residual Oil
- LO** = Lubricating Oil
- WM** = Wear Metals (Unulfonated)
- A** = Sulfonated Wear Metals
- ORGM** = Organo-Metallic
- LOMS** = Lubricating Oil Metal Standards

### Elements of Primary Interest:

In most instances, the element of primary interest, but not necessarily of analytical interest, is placed prior to the alpha-string as a prefix. For example, in the aforementioned alpha-strings the appearance of an "S" prior to the alpha-string "MO" is indicative that the element of primary interest is Sulfur, "SMO"; similarly "SDF" would represent Sulfur in Diesel Fuel; "SRO" would represent Sulfur in residual oil; "SEPA" represents Sulfur according to the EPA methodology; "CLSMO" would represent Chlorine and Sulfur in Mineral Oil; "CLWO" would denote Chlorine in "Waste Oil"; "SNVMO" and SFNVMO" Sulfur with Nickel and Vanadium and Sulfur with Iron (Ferrous) with Nickel and Vanadium, respectively, in Mineral Oil. "SNVRO" and SFNVRO" implies Sulfur with nickel and vanadium and sulfur with iron (ferrous), nickel and vanadium in residual oil, respectively.

### Numeric Sequence:

The numeric sequences following the alpha-strings are generally related to a combination of specifications. The first numeric sequence relates to the number of standards comprising a set, a procedure or "L" or "H" representing low or high in concentration, respectively, in SEPA(G)L, where "S" is Sulfur, "EPA" connotes the methodology "G" represents "Gravimetric" and "L" represents "Low" concentration. For multi-element concentrations the combination of the numbering sequence denotes the number of multi-elements in a standard and their respective concentration levels, e.g. "WM20-10", Wear Metal containing 20 elements each at a concentration of 10 PPM. "A" is representative of sulfonated wear metal constituents. Concentrated Lubricating Oil Metal Standards, LOMS" is simply followed by the chemical symbol and its concentration level.

### Table Groupings:

Similar Alpha strings are arranged in tabular form and whenever possible within proximity to each other and on the same page.

## Biodiesel SpectroCertified® Testing Standards

Sample Cups  
and Accessories

Thin-Film  
Sample Supports

Grinding Machines  
and Accessories

Briquetting Presses  
and Accessories

Grinding/Briquetting  
Additives

Fusion Machines  
and Accessories

Standards and  
XRF/XRD Chemical Kits

Calibration standards and chemicals are available in accordance with the methodologies indicated by ASTM, DIN, UOP and ACOS for testing biodiesel fuels. Includes Certificates of Analysis.



### BIODIESEL FUEL SULFUR SETS (ASTM D5453 Method)

Cat No.	Description
S(BIO)6L	DBS in Biodiesel Fuel Set; Low Concentration Range. 6 Standards per set; 100 ml of each. Concentrations: 0.0, 5, 10, 15, 20 and 25 PPM S
S(BIO)6H	DBS in Biodiesel Fuel Set; High Concentration Range. 6 Standards per set; 100 ml of each. Concentrations: 0.0, 200, 400, 600, 800 and 1000 PPM S

### BIODIESEL FREE AND TOTAL GLYCERINE SETS (ASTM D6584 or DIN EN14105 Methods)

Cat No.	Description
D6584-MIX	Five standards containing the four glycerin components in pyridine in sealed ampoules as described in the methodology; one 5 ml quantity of 1000 ng/L butanetriol Internal Standard #1 in pyridine in a sealed ampoule; one 5 ml quantity of 8000 ng/L tricaprin Internal Standard #2 in pyridine in a sealed ampoule; one 5 ml quantity of N-methyl-N-trimethylsilyltri-fluoro aceamidine (MSTFA) silylating reagent in a capped vial; and one 250 ml amber bottle of heptane.
D6584-SS	One 5 ml quantity of 500 ng/uL glycerin in pyridine in a sealed ampoule; one 5 ml quantity of 5000 ng/L 1-Mono (cis-9-octadecanoyl)-rac-glycerol (monoolein in pyridine in a sealed ampoule; one 5 ml quantity of 500 ng/L 1,3-Di(cis-octadecanoyl) glycerol (dialen) in pyridine in a sealed ampoule; one 1,2,3-Tri (cis-octadecanoyl) in pyridine in a sealed ampoule; one 5 ml 1000 ng/L butanetriol Internal Standard #1 in pyridine in a sealed ampoule; one 5 ml quantity of 8000 ng/L tricaprin Internal Standard #2 in pyridine in a sealed ampoule; one 5 ml quantity of N-methyl-N-trimethylsilyltri-fluoro aceamidine (MSTFA) silylating reagent in a capped vial; and one 250 ml amber bottle of heptane.
D6584-50KIT	Multi-Run Kit: Adequate quantities for 50 GC runs; one 5 ml sealed ampoule of Internal Standard #1; one 5 ml sealed ampoule of Internal Standard #2; and one 5 ml sealed ampoule of MSTFA.
D6584-100KIT	Multi-Run Kit: Adequate quantities for 100 GC runs; one 10 ml sealed ampoule of Internal Standard #1; one 10 ml sealed ampoule of Internal Standard #2; and one 10 ml sealed ampoule of MSTFA.
D6584-250KIT	Multi-Run Kit: Adequate quantities for 250 GC runs; one 25 ml sealed ampoule of Internal Standard #1; one 25 ml sealed ampoule of Standard #2; and one 25 ml sealed ampoule of MSTFA.
D6584-500KIT	Multi-Run Kit: Adequate quantities for 500 GC runs; one 50 ml sealed ampoule of Internal Standard #1; one 50 ml sealed ampoule of Internal Standard #2; and one 50 ml sealed ampoule of MSTFA.

**EXAMPLES OF TYPICAL CONCENTRATIONS  
(D6584-MIX)**

Sample No.	Glycerin, mg/L	Monoolein, mg/L	Diolen, mg/L	Triolein, mg/L
1	5	100	50	50
2	15	250	100	100
3	25	500	200	200
4	35	750	350	350
5	50	1000	500	500

**(D6584-SS)**

Sample No.	Glycerin, mg/L	Monoolein, mg/L	Diolen, mg/L	Triolein, mg/L	Butanetriol, mg/L	Tricaprin, mg/L
1	0.5					
2		5.0				
3			5.0			
4				5.0		
5					1.0	
6						8.0

**BIODIESEL SODIUM AND POTASSIUM  
(UOP 391 or DIN EN 14538 Methods)**

Cat No.	Description
UOP391	One 100 ml amber bottle containing 100 PPM each of Na and K.
UOP389	One 100 ml amber bottle containing 100 PPM each of Ca and Mg.
EN14538	One 100 ml amber bottle containing 500 PPM each of Ca, Mg, K and Na.
EN14538-2C	Set of two 100 ml amber bottles consisting of: 20 PPM each of Ca, Mg, K, P and Na; and 100 PPM each of Ca, Mg, K, P and Na.

**BIODIESEL METHANOL IN FAME SET  
(DIN EN14110 Method)**

Cat No.	Description
EN14110	Methanol in FAME Set consisting of three standards and one 20 ml sealed ampoule of 2-propanol.

**BIODIESEL FATTY ACID METHYL ESTERS (FAME) SETS  
(DIN EN 14103 Method)**

Cat No.	Description
EN14103	Fatty Acid Methyl Esters Set consisting of three standards and one 2 ml sealed ampoule of 2-propanol.
EN14103-IS	Fatty Acid Methyl Esters Set consisting of 100 ml of methylheptadecanoate in heptane.

**BIODIESEL IODINE VALUE SET  
(DIN EN14214 Method)**

Cat No.	Description
EN14214	Iodine Value Set consisting of 500 ml each of Iodine #50 and #200.

**BIODIESEL HEXANE RESIDUE IN FATS AND OIL SET  
(ACOS Method CA 36-87)**

Cat No.	Description
HEXME05	Hexane Residue in Fats and Oil Set consisting of five 20 ml quantities of hexane in methyloleate in sealed ampoules in concentrations of: blank, 10, 100, 500 and 1.500 mg/kg; and one 20 ml sealed ampoule of heptane as an Internal Standard.

**BIODIESEL SIMULATED DISTILLATION SET  
(ASTM D2887)**

Cat No.	Description
D2887	Diesel Reference Fuel Set consisting of a quantity of six 2 ml sealed ampoules.

- Sample Cups and Accessories
- Thin-Film Sample Supports
- Grinding Machines and Accessories
- Briquetting Presses and Accessories
- Grinding/Briquetting Additives
- Fusion Machines and Accessories
- Standards and XRF/XRD Chemical Kits

**SpectroCertified® Non-Aqueous Sulfur and Chlorine Standards**

Chemplex Industries, Inc. offers a unique assemblage of specially formulated sulfur standard reference materials in mineral and diesel fuel oil and chlorine in waste oil matrices in convenient concentration spread sets. Supplied in 100 cc quantities in glass bottles unless stated otherwise.



• **SULFUR SPECTROSTANDARDS® MINERAL OIL SETS**

Formulated with Di-N-butyl sulfide diluted to convenient concentration levels with mineral oil conforming to the indicated ASTM-D2622; D4294 and D4294-98, EPA or Canadian General Standards Board CAN/GS-3.0 No. 16.0-95 methods.

TABLE 1

CAT. NO	SULFUR CONCENTRATION, WT. %, IN MINERAL OIL										
	Std. No. 1	Std. No. 2	Std. No. 3	Std. No. 4	Std. No. 5	Std. No. 6	Std. No. 7	Std. No. 8	Std. No. 9	Std. No. 10	Std. No. 11
SMO10 <sup>1</sup>	0.0000	0.0025	0.0050	0.0100	0.0200	0.0400	0.0500	0.0600	0.0800	0.1000	
SMO11 <sup>2</sup>	0.0000	0.0020	0.0050	0.0100	0.0300	0.0600	0.1000	0.5000	1.0000	2.5000	5.0000
SMO7L <sup>2</sup>	0.0000	0.0020	0.0050	0.0100	0.0300	0.0600	0.1000				
SMO6H <sup>2</sup>	0.0000	0.1000	0.5000	1.0000	2.5000	5.0000					
SMO10HL <sup>1</sup>	0.0000	0.1000	0.2000	0.5000	0.7500	1.0000	2.0000	3.0000	4.0000	5.0000	
SMOCS6(L) <sup>3</sup>	0.0000	0.0100	0.0300	0.0500	0.0700	0.1000					
SMOCS5(H) <sup>3</sup>	0.1000	0.2000	0.3000	0.4000	0.5000						
SMOCS10 <sup>3</sup>	0.0000	0.0100	0.0300	0.0500	0.0700	0.1000	0.2000	0.3000	0.4000	0.5000	

<sup>1</sup> ASTM-D2622 and ASTM-4294. <sup>2</sup> ASTM-D4294-98. <sup>3</sup> CAN/GS-3.0 No. 16.0-95

• **SULFUR SPECTROSTANDARDS® MINERAL OIL SETS; PPM BASIS**

Formulated with Di-N butyl sulfide diluted to concentration with mineral oil conforming to ASTM-D7039.

TABLE 2

CAT. NO.	SULFUR CONCENTRATION, PPM, IN MINERAL OIL					
	STD. NO. 1	STD. NO. 2	STD. NO. 3	STD. NO. 4	STD. NO. 5	STD. NO. 6
SMO6(L)-H	0	2	5	10	15	20
SIN-6C	0	10	50	100	200	500
SMO6(H)-H	0	100	200	400	800	1000

• **SULFUR SPECTROSTANDARDS® SYNTHETIC DIESEL FUEL SETS**

Formulated with Di-N-butyl sulfide concentrate diluted to convenient concentration levels with synthetic diesel fuel Oil. SDF7 conforms to ASTM-D4294 and SDF10 to ASTM D4294 and D2622 methods.

TABLE 3

CAT. NO.	SULFUR, WT. %, IN SYNTHETIC DIESEL FUEL									
	Std. No. 1	Std. No. 2	Std. No. 3	Std. No. 4	Std. No. 5	Std. No. 6	Std. No. 7	Std. No. 8	Std. No. 9	Std. No. 10
SDF7	0.0000	0.0200	0.0400	0.0500	0.0600	0.0800	0.1000			
SDF10	0.0000	0.1000	0.2500	0.5000	1.0000	1.5000	2.0000	3.0000	4.0000	5.0000

• **ULTRA LOW SULFUR SPECTROSTANDARDS® SYNTHETIC DIESEL FUEL SETS; PPM BASIS.**

Formulated with Di-N butyl sulfide diluted to concentration with diesel fuel

TABLE 4

CAT. NO.	ULTRA LOW SULFUR, PPM, IN DIESEL FUEL					
	Std. No. 1	Std. No. 2	Std. No. 3	Std. No. 4	Std. No. 5	Std. No. 6
ULSDO-25	0	5	10	15	20	25
ULSD20-100	20	40	60	80	100	

• **SULFUR SPECTROSTANDARDS® RESIDUAL OIL SET**

Formulated with Di-N-butyl sulfide concentrate diluted to convenient concentration levels with residual oil in conforming to ASTM-D2622 and D4294-98 methods.

TABLE 5

CAT. NO.	SULFUR, WT. %, IN RESIDUAL OIL									
	Std. No. 1	Std. No. 2	Std. No. 3	Std. No. 4	Std. No. 5	Std. No. 6	Std. No. 7	Std. No. 8	Std. No. 9	Std. No. 10
SRO10	0.2500	0.5000	1.0000	1.5000	2.0000	2.5000	3.0000	3.5000	4.0000	5.0000

• **SULFUR SPECTROSTANDARDS® FORMULATION SETS FOR EPA METHODS 80.580 TO 80.585**

**Mineral Oil Matrix Sets:**

Sulfur in Mineral Oil Gravimetric standard for low-high level EPA requirements. Set of two (2) SpectroCertified® standards contain **200 cc** quantities of each SpectroStandards.

**Diesel Fuel Matrix Sets:**

Sulfur in Diesel Fuel Precision standard for low-high level EPA requirements. Set of two (2) SpectroCertified® standards contain **400 cc** of each SpectroStandards.

TABLE 6

CAT. NO.	SULFUR, PPM, IN MINERAL OIL; GRAVIMETRIC STANDARD	
	STD. NO. 1	STD. NO. 2
SEPA(G)L	5	15
SEPA(G)H	150	450

TABLE 7

CAT. NO.	SULFUR, PPM, IN DIESEL FUEL; PRECISION STANDARD
	SEPA(P)L
SEPA(P)H	300

• **COMBINATION SET OF MINERAL OIL AND DIESEL FUEL BASE STANDARD**

A complete set comprising the sulfur content of all Mineral Oil Gravimetric and Diesel Fuel Precision standards constituting the EPA methods 80.580 to 80.585. Consists of the above-indicated sets.

TABLE 8

CAT. NO.	COMBINATION SET OF SULFUR IN MINERAL OIL AND DIESEL FUEL
	SETS INCLUDED (4)
SEPA6C	SEPA(G)H, SEPA(G)L, SEPA(P)H and SEPA(P)L

TABLE 9

CAT. NO: CLSMO10		
STD. NO.	% SULFUR	% CHLORINE
1	0.0000	0.0000
2	0.1000	0.8000
3	0.6000	0.5000
4	0.2000	0.3000
5	0.7000	0.2000
6	0.3000	0.6000
7	0.4000	0.1000
8	0.5000	0.4000
9	0.8000	1.0000
10	1.0000	0.0000

TABLE 10

CAT. NO: CLSWO10		
STD. NO.	% SULFUR	% CHLORINE
1	0.5000	1.0000
2	2.5000	0.0200
3	0.5000	0.6500
4	1.0000	0.2000
5	1.5000	0.5000
6	1.7500	0.8000
7	1.2500	0.0500
8	2.0000	1.0000
9	2.2500	0.3800
10	0.7500	0.1000

• **CHLORINE IN WASTE OIL SET**

Chlorinated hydrocarbon in waste oil

TABLE 11

CAT. NO.	CHLORINE, WT. %, IN WASTE OIL						
	STD. NO. 1	STD. NO. 2	STD. NO. 3	STD. NO. 4	STD. NO. 5	STD. NO. 6	STD. NO. 7
LWO7	0.0500	0.2000	0.4000	0.5000	0.6000	0.8000	1.0000

**SpectroStandards<sup>®</sup> Quality Standards for Sulfur and Metal in Fuel and Residual Oil Matrices**

SpectroStandards Quality fuel and residual oil standards are formulated to maintain consistent sulfur content within each matrix. The metallic contents are varied for analytical calibration spreads. Each SpectroStandard matrix composition consists of 100 cc each of twelve (12) standard sets encompassing the concentration ranges generally investigated.

**TABLE 12**

SULFUR, NICKEL AND VANADIUM IN MINERAL OIL MATRIX SET CAT. NO: SNVMO12			
STD. NO.	SULFUR, WT. %	NICKEL, PPM	VANADIUM, PPM
1	0.0000	0	0
2	0.5000	10	500
3	1.0000	100	25
4	1.5000	80	250
5	2.0000	40	100
6	2.5000	5	400
7	3.0000	60	300
8	3.5000	0	200
9	4.0000	100	0
10	4.5000	50	250
11	5.0000	20	500
12	5.5000	100	50

**TABLE 13**

SULFUR, IRON, NICKEL AND VANADIUM IN MINERAL OIL MATRIX SET CAT. NO: SFNVMO12				
STD. NO.	SULFUR, WT. %	IRON, PPM	NICKEL, PPM	VANADIUM, PPM
1	0.0000	0	0	0
2	0.5000	300	10	500
3	1.0000	500	100	25
4	0.0000	100	80	250
5	2.0000	200	40	100
6	2.5000	400	5	400
7	3.0000	0	60	300
8	3.5000	500	0	200
9	0.0000	100	100	0
10	4.5000	300	50	250
11	5.0000	200	20	500
12	5.5000	50	100	50

**TABLE 14**

SULFUR, NICKEL AND VANADIUM IN RESIDUAL OIL MATRIX SET CAT. NO: SNVRO12			
STD. NO.	SULFUR, WT. %	NICKEL, PPM	VANADIUM, PPM
1	0.1850	4	1
2	0.5000	10	500
3	1.0000	100	25
4	1.5000	80	250
5	2.0000	40	100
6	2.5000	5	400
7	3.0000	60	300
8	3.5000	0	200
9	4.0000	100	0
10	4.5000	50	250
11	5.0000	20	500
12	5.5000	100	50

**TABLE 15**

SULFUR, IRON, NICKEL AND VANADIUM IN RESIDUAL OIL MATRIX SET CAT. NO: SFNVRO12				
STD. NO.	SULFUR, WT. %	IRON, PPM	NICKEL, PPM	VANADIUM, PPM
1	0.1850	1	4	13
2	0.5000	300	10	500
3	1.0000	500	100	25
4	0.0000	100	80	250
5	2.0000	200	40	100
6	2.5000	400	5	400
7	3.0000	1	60	300
8	3.5000	500	4	200
9	0.0000	100	100	13
10	4.5000	300	50	250
11	5.0000	200	20	500
12	5.5000	50	100	50

**SpectroCertified® Lubricating Oil  
SpectroStandards® Sets**

- Sample Cups and Accessories
- Thin-Film Sample Supports
- Grinding Machines and Accessories
- Briquetting Presses and Accessories
- Grinding/Briquetting Additives
- Fusion Machines and Accessories
- Standards and XRF/XRD Chemical Kits

Lubricating oil standards are formulated from chelated and stabilized liquid organo-metallic solutions. The starting substances are representative of ultra-pure reagents certified against NIST standard reference materials, whenever available. The standards are processed in accordance with ASTM-D6481, 6443 and 4927 methodologies. Unless stated otherwise, they are free of phosphorus or sulfur content. Trace impurities are documented on the Certificate of Analysis. Supplied in glass bottles in sets consisting of 100 cc per standard.

**QUICK REFERENCE GUIDE FOR PRODUCT SPECIFICATIONS**

From the following chart, locate the analytes of interest to the corresponding product catalog number. Advance to the appropriate table number to peruse the technical specifications.

**CHART A  
(Lubricating Oil Additives)**

CAT. NO.	CLICK ON TABLE NUMBER	UNITS PER SET	LUBRICATING OIL ADDITIVES							
			Ca	P	S	Zn	Ba	Cl	Mg	Cu
LOA11	16	11								
LOE17	17	17								
LOEASTM1	18	17								
LOEASTM4	19	17								
LOE17A	20	17								
LOE17B	21	17								
LOE17C	22	17								
LOE17A/B	23	17								
LOE17B/C	24	17								
LOE10	25	10								
LOEASTM2	26	10								
LOE22	27	22								
LOE23	28	23								

**• LUBRICATING OIL SETS WITH Ca, P, S and Zn ADDITIVES**

**TABLE 16**

LUBRICATING OIL WITH Ca, P, S and Zn ADDITIVES				
CAT. NO: LOA11				
STD. NO.	Ca Wt. %	P Wt. %	S Wt. %	Zn Wt. %
1	0.5000	1.0000	0.5000	0.5000
2	2.5000	1.0000	2.5000	2.0000
3	2.0000	1.2500	1.0000	1.5000
4	5.0000	0.0000	0.0000	0.0000
5	4.0000	0.5000	1.2500	0.5000
6	2.5120	0.7500	4.0000	1.0000
7	4.0000	0.0000	1.5000	1.0000
8	0.5080	2.0000	5.0000	1.0000
9	1.0000	0.7500	2.0000	1.5000
10	2.5000	1.2000	3.0000	0.5000
11	0.0000	0.0000	0.0000	0.0000

**TABLE 17**

LUBRICATING OIL WITH Ca, P, S and Zn				
ADDITIVES				
CAT. NO: LOE17				
STD. NO.	Ca Wt. %	P Wt. %	S Wt. %	Zn Wt. %
1	0.6000	0.0050	0.1750	0.0600
2	0.5000	0.2000	0.0500	0.0800
3	0.4000	0.1500	0.3000	0.1800
4	0.2600	0.2500	0.1500	0.1200
5	0.0050	0.0050	0.4500	0.0700
6	0.4000	0.0250	0.3500	0.1000
7	0.3000	0.0600	0.2500	0.1200
8	0.2000	0.1000	0.4500	0.1000
9	0.0000	0.0800	0.3000	0.1300
10	0.0600	0.0500	0.2000	0.0500
11	0.0500	0.1200	0.1000	0.0750
12	0.0250	0.1500	0.2000	0.1300
13	0.0050	0.2000	0.4000	0.1500
14	0.1700	0.2500	0.5500	0.1100
15	0.1000	0.1000	0.2000	0.2000
16	0.0100	0.0100	0.6000	0.2500
17	0.0000	0.0000	0.0000	0.0000

**TABLE 18**

LUBRICATING OIL WITH Ca, P, S and Zn				
ADDITIVES				
CAT. NO: LOEASTM1				
STD. NO.	Ca Wt. %	P Wt. %	S Wt. %	Zn Wt. %
1	0.0050	0.0050	0.0500	0.0500
2	0.6000	0.0000	0.0000	0.0000
3	0.0000	0.3000	0.0000	0.0000
4	1.0000	0.0000	1.0000	0.0000
5	0.0000	0.0000	0.0000	0.3000
6	0.0050	0.2500	0.8000	0.3000
7	0.5000	0.1500	0.5000	0.1500
8	0.0100	0.2000	0.1000	0.2500
9	0.0500	0.0100	0.4000	0.0750
10	0.1000	0.1500	0.2000	0.2000
11	0.2000	0.2000	0.8000	0.1000
12	0.4000	0.0050	0.8000	0.3000
13	0.6000	0.1000	0.5000	0.0500
14	0.8000	0.0100	0.0500	0.1000
15	1.0000	0.3000	1.0000	0.1500
16	0.4000	0.0500	0.6000	0.2500
17	0.0000	0.0000	0.0000	0.0000

• **LUBRICATING OIL SETS WITH Ca, P, S, Zn and Mg ADDITIVES**

Same as Cat. No. LOEASTM1 but also contains magnesium.

**TABLE 19**

LUBRICATING OIL WITH Ca, P, S, Zn and Mg					
ADDITIVES					
CAT. NO: LOEASTM4					
STD. NO.	Ca Wt. %	P Wt. %	S Wt. %	Zn Wt. %	Mg Wt. %
1	0.0050	0.0050	0.0500	0.0500	0.1000
2	0.6000	0.0000	0.0000	0.0000	0.1500
3	0.0000	0.3000	0.0000	0.0000	0.3500
4	1.0000	0.0000	1.0000	0.0000	0.2250
5	0.0000	0.0000	0.0000	0.3000	0.4500
6	0.0050	0.2500	0.8000	0.3000	0.5000
7	0.5000	0.1500	0.5000	0.1500	0.3250
8	0.0100	0.2000	0.1000	0.2500	0.2500
9	0.0500	0.0100	0.4000	0.0750	0.0500
10	0.1000	0.1500	0.2000	0.2000	0.4000
11	0.2000	0.2000	0.8000	0.1000	0.3000
12	0.4000	0.0050	0.8000	0.3000	0.2000
13	0.6000	0.1000	0.5000	0.0500	0.3750
14	0.8000	0.0100	0.0500	0.1000	0.1750
15	1.0000	0.3000	1.0000	0.1500	0.4250
16	0.4000	0.0500	0.6000	0.2500	0.2750
17	0.0000	0.0000	0.0000	0.0000	0.0000

• **LUBRICATING OIL SETS WITH Ca, P, S, Zn and Cl ADDITIVES**

Same as Cat. No. LOE17 but also contains chlorine.

**TABLE 20**

LUBRICATING OIL WITH Ca, P, S, Zn and Cl					
ADDITIVES					
CAT. NO: LOE17A					
STD. NO.	Ca Wt. %	P Wt. %	S Wt. %	Zn Wt. %	Cl Wt. %
1	0.6000	0.0050	0.1750	0.0600	0.1000
2	0.5000	0.2000	0.0500	0.0800	0.0000
3	0.4000	0.1500	0.3000	0.1800	0.0100
4	0.2600	0.2500	0.1500	0.1200	0.5000
5	0.0050	0.0050	0.4500	0.0700	1.0000
6	0.4000	0.0250	0.3500	0.1000	0.4000
7	0.3000	0.0600	0.2500	0.1200	0.1000
8	0.2000	0.1000	0.4500	0.1000	0.0100
9	0.0600	0.0800	0.3000	0.1300	0.0500
10	0.0600	0.0500	0.2000	0.0500	0.2000
11	0.0500	0.1200	0.1000	0.0750	0.5000
12	0.0250	0.1500	0.2000	0.1300	0.8000
13	0.0050	0.2000	0.4000	0.1500	1.0000
14	0.1700	0.2500	0.5500	0.1100	0.6000
15	0.1000	0.1000	0.2000	0.2000	0.2000
16	0.0100	0.0100	0.6000	0.2500	0.4000
17	0.0000	0.0000	0.0000	0.0000	0.0000







**SpectroStandards® Multi-Element Wear Metal  
Organo-Metallic Standards**

- Sample Cups and Accessories
- Thin-Film Sample Supports
- Grinding Machines and Accessories
- Briquetting Presses and Accessories
- Grinding/Briquetting Additives
- Fusion Machines and Accessories
- Standards and XRF/XRD Chemical Kits**



The analysis of metal content in lubricating oils is an ordinary procedure for monitoring and predicting frictional wear of constituent parts in various types of machinery. SpectroStandards multi-element wear metal standards are formulated in a specialized lubricating oil matrix to closely resemble the sample substances. They are intended for various instrument calibration purposes and provided in individual units each consisting of 100 cc; concentrations are expressed in PPM. Each SpectroCertified standard is accompanied with a certificate of analysis.

**• INDIVIDUAL UNSULFONATED MULTI-ELEMENT WEAR METAL STANDARDS**

Formulated with unsulfonated Organo-metallic concentrates and diluted to concentration with sulfur-free lubricating oil, 20 cSt. viscosity. Ideally suitable for instrument standardization procedures by XRF, AA, ICP or AE applications where the presence of sulfur potentially presents interference issues.

**TABLE 29**

<b>11 INDIVIDUAL MULTI-ELEMENT WEAR METALS IN OIL STANDARDS</b>	
<b>ELEMENTS: Al, Cr, Cu, Fe, Mg, Na, Ni, Pb, Si, Sn and Ti</b>	
<b>CAT. NO</b>	<b>CONCENTRATION, PPM</b>
WM11-10	10
WM11-30	30
WM11-50	50
WM11-100	100
WM11-300	300
WM11-500	500
WM11-900	900

**TABLE 30**

<b>12 INDIVIDUAL MULTI-ELEMENT WEAR METALS IN OIL STANDARDS</b>	
<b>ELEMENTS: Ag, Al, Cr, Cu, Fe, Mg, Na, Ni, Pb, Si, Sn and Ti</b>	
<b>CAT. NO.</b>	<b>CONCENTRATION, PPM</b>
WM12-10	10
WM12-30	30
WM12-50	50
WM12-100	100
WM12-300	300
WM12-500	500
WM12-750	750
WM12-900	900

**TABLE 31**

<b>20 INDIVIDUAL MULTI-ELEMENT WEAR METALS IN OIL STANDARDS</b>	
<b>ELEMENTS: Al, B, Ba, Ca, Cd, Cr, Cu, Fe, Mg, Mn, Mo, Na, Ni, P, Pb, Si, Sn, Ti, V and Zn</b>	
<b>CAT. NO.</b>	<b>CONCENTRATION, PPM</b>
WM20-10	10
WM20-30	30
WM20-50	50
WM20-100	100
WM20-300	300
WM20-500	500
WM20-900	900

**TABLE 32**

<b>21 INDIVIDUAL MULTI-ELEMENT WEAR METALS IN OIL STANDARDS</b>	
<b>ELEMENTS: Ag, Al, B, Ba, Ca, Cd, Cr, Cu, Fe, Mg, Mn, Mo, Na, Ni, P, Pb, Si, Sn, Ti, V and Zn</b>	
<b>CAT. NO.</b>	<b>CONCENTRATION, PPM</b>
WM21-10	10
WM21-30	30
WM21-50	50
WM21-100	100
WM21-200	200
WM21-300	300
WM21-500	500
WM21-750	750
WM21-900	900

• **SULFONATED MULTI-ELEMENT WEAR METAL STANDARDS**

For wear metal analytical procedures unconcerned with the presence of sulfur, the following listed standards are supplied as individual units each containing 100 cc quantities. They are suited for ICP, RDE and other analytical techniques.

**TABLE 33**

20 INDIVIDUAL MULTI-ELEMENT WEAR METALS IN SULFONATED STANDARDS	
CAT. NO.	ELEMENTS: Ag, Al, B, Ba, Ca, Cd, Cr, Cu, Fe, Mg, Mo, Na, Ni, P, Pb, Si, Sn, Ti, V, Zn in Hydrocarbon Oil.
	CONCENTRATION, PPM
A21-10	10
A21-30	30
A21-50	50
A21-100	100
A21-300	300
A21-500	500
A21-900	900

**TABLE 34**

(Same as Table 33 but includes K)

21 INDIVIDUAL MULTI-ELEMENT WEAR METALS IN SULFONATED STANDARDS	
CAT. NO.	ELEMENTS: Ag, Al, B, Ba, Ca, Cd, Cr, Cu, Fe, K, Mg, Mo, Na, Ni, P, Pb, Si, Sn, Ti, V, Zn in Hydrocarbon Oil.
	CONCENTRATION, PPM
A22-10	10
A22-30	30
A22-50	50
A22-100	100
A22-300	300
A22-500	500
A22-900	900

**TABLE 35**

(Same as Table 34 but includes K and Sb)

22 INDIVIDUAL MULTI-ELEMENT WEAR METALS IN SULFONATED STANDARDS	
CAT. NO.	ELEMENTS: Ag, Al, B, Ba, Ca, Cd, Cr, Cu, Fe, K, Mg, Mo, Na, Ni, P, Pb, Sb, Si, Sn, Ti, V, Zn in Hydrocarbon Oil.
	CONCENTRATION, PPM
A23-10	10
A23-30	30
A23-50	50
A23-100	100
A23-300	300
A23-500	500
A23-900	900

**SpectroStandards<sup>®</sup> Individual Diluted Single-Element  
Organo-Metallic Oil Standards**



SpectroStandards<sup>®</sup> Organo-metallic standard solutions are chelated and stabilized standards diluted to low concentration levels ready-for-use, for preparing subsequent single element dilutions or for preparing multi-element standards. The standards are sulfur free, unless otherwise noted, and intended for x-ray fluorescence (XRF), plasma emission (ICP or DCP), rotating disk (rotrode) or atomic absorption (AA) analyses. A certificate of analysis accompanies each item; supplied in glass bottles containing 100 cc of standard.

- Sample Cups and Accessories
- Thin-Film Sample Supports
- Grinding Machines and Accessories
- Briquetting Presses and Accessories
- Grinding/Briquetting Additives
- Fusion Machines and Accessories
- Standards and XRF/XRD Chemical Kits**

**TABLE 36**

CAT. NO.	ELEMENT	Wt %, Z
ORGM-Al0.1	Aluminum	0.1000
ORGM-Al0.5	Aluminum	0.5000
ORGM-Sb0.1	Antimony	0.1000
ORGM-Sb0.5	Antimony	0.5000
ORGM-As0.1	Arsenic	0.1000
ORGM-As0.5	Arsenic	0.5000
ORGM-Ba0.1	Barium	0.1000
ORGM-Ba0.5	Barium	0.5000
ORGM-Be0.1	Beryllium	0.1000
ORGM-Be0.5	Beryllium	0.5000
ORGM-Cd0.1	Cadmium	0.1000
ORGM-Cd0.5	Cadmium	0.5000
ORGM-Ca0.1	Calcium	0.1000
ORGM-Ca0.5	Calcium	0.5000
ORGM-Ce0.1	Cerium	0.1000
ORGM-Ce0.5	Cerium	0.5000
ORGM-Cr0.1	Chromium	0.1000
ORGM-Cr0.5	Chromium	0.5000
ORGM-Co0.1	Cobalt	0.1000
ORGM-Co0.5	Cobalt	0.5000
ORGM-Cu0.1	Copper	0.1000
ORGM-Cu0.5	Copper	0.5000
ORGM-Ga0.1	Gallium	0.1000
ORGM-Ga0.5	Gallium	0.5000

CAT. NO.	ELEMENT	Wt %, Z
ORGM-Au0.1	Gold	0.1000
ORGM-Fe0.1	Iron	0.1000
ORGM-Fe0.5	Iron	0.5000
ORGM-Pb0.1	Lead	0.1000
ORGM-Pb0.5	Lead	0.5000
ORGM-Li0.1	Lithium	0.1000
ORGM-Li0.5	Lithium	0.5000
ORGM-Mg0.1	Magnesium	0.1000
ORGM-Mg0.5	Magnesium	0.5000
ORGM-Mn0.1	Manganese	0.1000
ORGM-Mn0.5	Manganese	0.5000
ORGM-Hg0.1	Mercury	0.1000
ORGM-Hg0.5	Mercury	0.5000
ORGM-Mo0.1	Molybdenum	0.1000
ORGM-Mo0.5	Molybdenum	0.5000
ORGM-Ni0.1	Nickel	0.1000
ORGM-Ni0.5	Nickel	0.5000
ORGM-P0.1	Phosphorous	0.1000
ORGM-P0.5	Phosphorous	0.5000
ORGM-K0.1	Potassium	0.1000
ORGM-K0.5	Potassium	0.5000
ORGM-Se0.1	Selenium	0.1000
ORGM-Se0.5	Selenium	0.5000

CAT. NO.	ELEMENT	Wt %, Z
ORGM-Si0.1	Silicon	0.1000
ORGM-Si0.5	Silicon	0.5000
ORGM-Ag0.1	Silver	0.1000
ORGM-Ag0.5	Silver	0.5000
ORGM-Na0.1	Sodium	0.1000
ORGM-Na0.5	Sodium	0.5000
ORGM-Sr0.1	Strontium	0.1000
ORGM-Sr0.5	Strontium	0.5000
ORGM-Tl0.1	Thallium	0.1000
ORGM-Tl0.5	Thallium	0.5000
ORGM-Sn0.1	Tin	0.1000
ORGM-Sn0.5	Tin	0.5000
ORGM-Ti0.1	Titanium	0.1000
ORGM-Ti0.5	Titanium	0.5000
ORGM-V0.1	Vanadium	0.1000
ORGM-V0.5	Vanadium	0.5000
ORGM-Y0.1	Yttrium	0.1000
ORGM-Y0.5	Yttrium	0.5000
ORGM-Zn0.1	Zinc	0.1000
ORGM-Zn0.5	Zinc	0.5000
ORGM-Zr0.1	Zirconium	0.1000
ORGM-Zr0.5	Zirconium	0.5000

Sample Cups  
and Accessories

Thin-Film  
Sample Supports

Grinding Machines  
and Accessories

Briquetting Presses  
and Accessories

Grinding/Briquetting  
Additives

Fusion Machines  
and Accessories

Standards and  
XRF/XRD Chemical Kits

## SpectroStandards® Individual Concentrated Single-Element Organo-Metallic Oil Standards



SpectroCertified® Organo-metallic concentrated standard solutions are formulated with a proprietary chelate and stabilized to avert metallic content precipitation out of solution. The starting materials are representative of ultra-pure reagents certified against NIST standard reference materials, whenever available. The solution standards do not contain phosphorus or sulfur, unless otherwise noted. They are particularly useful in formulating sets of standards for the analysis of additive elements in lubricating oils; nickel and vanadium in residual and wear metals in oils by x-ray fluorescence (XRF) spectroscopy. These standards are inter-miscible for optional preparations of diluted standards with Chemplex® Base Oil, Cat. No: 5900, and for multi-element formulations for plasma emission (ICP or DCP), rotating disk (rotrode) and atomic absorption (AA) analyses. Each item is accompanied with a certificate of analysis that documents any trace impurities; supplied in glass bottles each containing 100 gm of concentrated liquid standard.

**TABLE 37**

CAT. NO.	ELEMENT	SYM.	Wt. % Z
LOMSAI 3.0	Aluminum	Al	3.0000
LOMSSb 2.0	Antimony	Sb	2.0000
LOMSBa 12.5	Barium	Ba	12.500
LOMSCd 10.0	Cadmium	Cd	10.000
LOMSCa 5.0	Calcium	Ca	5.0000
LOMSCe 5.0	Cerium	Ce	5.0000
LOMSCr3.50	Chromium	Cr	3.5000
LOMSCo 7.5	Cobalt	Co	7.5000
LOMSCu 6.0	Copper	Cu	6.0000
LOMSFe 4.0	Iron	Fe	4.0000
LOMSPb 20.0	Lead	Pb	20.000
LOMSLi 1.5	Lithium	Li	1.5000
LOMSMg 3.0	Magnesium	Mg	3.0000
LOMSMn 6.0	Manganese	Mn	6.0000
LOMSMo 5.0	Molybdenum	Mo	5.0000

CAT. NO.	ELEMENT	SYM.	Wt. % Z
LOMSNi 5.0	Nickel	Ni	5.0000
LOMSP 5.0	Phosphorus	P	5.0000
LOMSK 7.5	Potassium	K	7.5000
LOMSPr 3.0	Praseodymium	Pr	3.0000
LOMSSe 3.5	Selenium	Se	3.5000
LOMSSi 7.5	Silicon	Si	7.5000
LOMSNa 2.5	Sodium	Na	2.5000
LOMSSr 10.0	Strontium	Sr	10.000
LOMSTl 5.0	Thallium	Tl	5.0000
LOMSSn 7.5	Tin	Sn	7.5000
LOMSTi 5.0	Titanium	Ti	5.0000
LOMSV 4.0	Vanadium	V	4.0000
LOMSY 2.5	Yttrium	Y	2.5000
LOMSZn 6.0	Zinc	Zn	6.0000
LOMSZr 5.0	Zirconium	Zr	5.0000

- Sample Cups and Accessories
- Thin-Film Sample Supports
- Grinding Machines and Accessories
- Briquetting Presses and Accessories
- Grinding/Briquetting Additives
- Fusion Machines and Accessories
- Standards and XRF/XRD Chemical Kits

## SpectroStandards® Single-Element Sulfur Concentration in Mineral, Residual and Diesel Oil Matrices



For applications where there is little need to acquire complete sets of standards for monitoring the sulfur content in mineral, diesel or residual oil, single-element sulfur SpectroStandards® Sulfur Standards are available. Each standard is formulated in its respective matrix with Di-N-butyl sulfide and accompanied with appropriate certification of analysis; supplied in 100 cc quantities in glass bottles unless stated otherwise.

• **SULFUR SINGLE-ELEMENT SPECTROSTANDARDS® MINERAL OIL MATRIX**

Formulated with Di-N-butyl sulfide diluted to convenient concentration levels with mineral oil conforming to ASTM-D2622 and D4294. Supplied in glass bottles in 100 cc quantities per standard.

**SPECIFICATIONS AND ORDERING INFORMATION**  
**ORDER BY CATALOG NUMBER FOLLOWED BY THE STANDARD NUMBER**

**TABLE 38**

SINGLE-ELEMENT SULFUR, WT. %, IN MINERAL OIL										
CAT. NO.	Std. No. 1	Std. No. 2	Std. No. 3	Std. No. 4	Std. No. 5	Std. No. 6	Std. No. 7	Std. No. 8	Std. No. 9	Std. No. 10
	SMO10	0.0000	0.0025	0.0050	0.0100	0.0200	0.0400	0.0500	0.0600	0.0800
SMO10HL		0.1000	0.2000	0.5000	0.7500	1.0000	2.0000	3.0000	4.0000	5.0000

• **SULFUR SPECTROSTANDARD® MINERAL OIL SETS; PPM BASIS**

Formulated with Di-N butyl sulfide diluted to concentration with mineral oil conforming to ASTM-D7039.

**TABLE 39**

CAT. NO.	SULFUR CONCENTRATION, PPM, IN MINERAL OIL					
	STD. NO.	STD. NO.	STD. NO.	STD. NO.	STD. NO.	STD. NO.
	1	2	3	4	5	6
SMO6(L)-H	0	2	5	10	15	20
SMO5(M)-L				25	50	
SMO6(H)-H		100	200	400	800	1000

• **SULFUR SINGLE-ELEMENT SPECTROSTANDARD® SYNTHETIC DIESEL FUEL MATRIX**

Formulated with Di-N-butyl sulfide concentrate diluted to convenient concentration levels with synthetic diesel fuel Oil. SDF7 conforms to ASTM-D4294 and SDF10 to ASTM D4294 and D2622 methods; supplied in glass bottles in 100 cc quantities per standard.

**TABLE 40**

CAT. NO.	SINGLE-ELEMENT SULFUR, WT. %, IN SYNTHETIC DIESEL FUEL									
	Std. No. 1	Std. No. 2	Std. No. 3	Std. No. 4	Std. No. 5	Std. No. 6	Std. No. 7	Std. No. 8	Std. No. 9	Std. No. 10
SDF7	0.0000	0.0200	0.0400	0.0500	0.0600	0.0800				
SDF10		0.1000	0.2500	0.5000	1.0000	1.5000	2.0000	3.0000	4.0000	5.0000

• **SULFUR SINGLE-ELEMENT SPECTROSTANDARD® RESIDUAL OIL MATRIX**

Formulated with Di-N-butyl sulfide concentrate diluted to convenient concentration levels with residual oil in conforming to ASTM-D2622 and D4294-98 methods; supplied in glass bottles in 100 cc quantities per standard.

**TABLE 41**

CAT. NO.	SINGLE-ELEMENT SULFUR, WT. %, IN RESIDUAL OIL									
	Std. No. 1	Std. No. 2	Std. No. 3	Std. No. 4	Std. No. 5	Std. No. 6	Std. No. 7	Std. No. 8	Std. No. 9	Std. No. 10
SRO10	0.2500	0.5000	1.0000	1.5000	2.0000	2.5000	3.0000	3.5000	4.0000	5.0000

- Sample Cups and Accessories
- Thin-Film Sample Supports
- Grinding Machines and Accessories
- Briquetting Presses and Accessories
- Grinding/Briquetting Additives
- Fusion Machines and Accessories
- Standards and XRF/XRD Chemical Kits

## Compliance Powdered Polymer Standards to RoHS/WHEE Directives

• **POLYETHYLENE (PE) POWDERED STANDARD SETS**

Polyethylene powdered standards are used for determining the indicated elemental constituents for complying with RoHS/WHEE directives. Supplied in sets consisting of 50 gm of each standard; includes a Quality Control Standard.

CAT. NO: PL(PE)3-5E(P)					
Standard Number	Br, Wt. %	Cd, Wt. %	Cr, Wt. %	Hg, Wt. %	Pb, Wt. %
1	0.0000	0.0000	0.0000	0.0000	0.0000
2	0.0250	0.0050	0.0500	0.0500	0.0500
3	0.0500	0.0100	0.1000	0.1000	0.1000
Quality Control Standard	0.0250	0.0050	0.0500	0.0500	0.0500

CAT. NO: PL(PE)9-5E(P)					
Standard Number	Br, Wt. %	Cd, Wt. %	Cr, Wt. %	Hg, Wt. %	Pb, Wt. %
1	0.0000	0.0000	0.0000	0.0000	0.0000
2	0.0050	0.0025	0.0050	0.0100	0.1000
3	0.0400	0.0100	0.0750	0.0075	0.0250
4	0.0100	0.0125	0.1250	0.0500	0.0050
5	0.0250	0.0075	0.1000	0.0250	0.1250
6	0.0500	0.0010	0.0650	0.0800	0.0750
7	0.0200	0.0005	0.0250	0.1000	0.0100
8	0.0300	0.0050	0.0500	0.0030	0.0500
9	0.0050	0.0150	0.0100	0.1200	0.0350
Quality Control Standard	0.0250	0.0050	0.0500	0.0500	0.0500

• **POLYVINYLCHLORIDE (PVC) POWDER STANDARD SETS**

Polyvinyl chloride powdered standards are used for determining the indicated elemental constituents. Also, contains Ca and Cl. Supplied in sets consisting of 50 gm of each standard; includes a Quality Control Standard.

CAT. NO: PL(PVC)3-5E(P)							
Standard Number	Br, Wt. %	Cd, Wt. %	Cr, Wt. %	Hg, Wt. %	Pb, Wt. %	Ca, Wt. %	Cl, Wt. %
1	0.0000	0.0000	0.0000	0.0000	0.0000	1.5000	15.00
2	0.0250	0.0050	0.0500	0.0500	0.0500	1.5000	15.00
3	0.0500	0.0100	0.1000	0.1000	0.1000	1.5000	15.00
Quality Control Standard	0.0250	0.0050	0.0500	0.0500	0.0500	0.0	35.0

CAT. NO: PL(PVC)9-5E(P)							
Standard Number	Br, Wt. %	Cd, Wt. %	Cr, Wt. %	Hg, Wt. %	Pb, Wt. %	Ca, Wt. %	Cl, Wt. %
1	0.0000	0.0000	0.0000	0.0000	0.0000	0.0	40.0
2	0.0050	0.0025	0.0050	0.0100	0.1000	0.500	35.0
3	0.0400	0.0100	0.0750	0.0075	0.0250	1.500	15.0
4	0.0100	0.0125	0.1250	0.0500	0.0050	0.250	40.0
5	0.0250	0.0075	0.1000	0.0250	0.1250	0.0	35.0
6	0.0500	0.0010	0.0650	0.0800	0.0750	3.0	10.0
7	0.0200	0.0005	0.0250	0.1000	0.0100	0.0	40.0
8	0.0300	0.0050	0.0500	0.0030	0.0500	2.0	12.5
9	0.0050	0.0150	0.0100	0.1200	0.0350	0.0	35.0
Quality Control Standard	0.0250	0.0050	0.0500	0.0500	0.0500	0.0	35.0



- Sample Cups and Accessories
- Thin-Film Sample Supports
- Grinding Machines and Accessories
- Briquetting Presses and Accessories
- Grinding/Briquetting Additives
- Fusion Machines and Accessories
- Standards and XRF/XRD Chemical Kits

## SpectroStandards® RoHS/WHEE Compliance Disc Polymer Sets

### • POLYETHYLENE (PE) DISC STANDARD SETS

Polyethylene powdered standards are transformed into solidified self-supporting discs contained in XRF Sample Cups for compliance applications to RoHS/WHEE directives. Available in two diameters: 32 mm x 10 mm thick contained in Chemplex XRF Sample Cups, Cat. No: 1330, and 40 mm x 10 mm thick in XRF Sample Cups, Cat. No: 1340; supplied in sets consisting of the indicated pre-mounted standards plus a Quality Control Standard.

#### SPECIFICATIONS AND ORDERING INFORMATION SPECIFY 32 MM OR 40 MM WHEN ORDERING

CAT. NO: PL(PE)3-5E(D)					
Standard Number	Br, Wt. %	Cd, Wt. %	Cr, Wt. %	Hg, Wt. %	Pb, Wt. %
1	0.0000	0.0000	0.0000	0.0000	0.0000
2	0.0250	0.0050	0.0500	0.0500	0.0500
3	0.0500	0.0100	0.1000	0.1000	0.1000

CAT. NO: PL(PE)9-5E(D)					
Standard Number	Br, Wt. %	Cd, Wt. %	Cr, Wt. %	Hg, Wt. %	Pb, Wt. %
1	0.0000	0.0000	0.0000	0.0000	0.0000
2	0.1000	0.0100	0.0010	0.0100	0.1000
3	0.1000	0.0100	0.1200	0.0150	0.0100
4	0.0100	0.0150	0.0750	0.0001	0.0010
5	0.0500	0.0075	0.1000	0.0075	0.1500
6	0.1500	0.0010	0.0500	0.0010	0.0075
7	0.0750	0.0001	0.0100	0.0200	0.0100
8	0.0100	0.0050	0.0500	0.0050	0.0500
9	0.0500	0.0150	0.0100	0.0050	0.0500
Quality Control Standard	0.0500	0.0050	0.0500	0.0500	0.0500

### • POLYVINYLCHLORIDE (PVC) DISC STANDARDS

Polyvinyl chloride powdered standards are transformed into solidified self-supporting discs contained in XRF Sample Cups for compliance applications, ease of handling and protection. Available in two diameters: 32 mm x 10 mm thick contained in Chemplex XRF Sample Cups, Cat. No. 1330, and 40 mm x 10 mm thick in XRF Sample Cups, Cat. No. 1340. Supplied in sets consisting of one each pre-mounted standard plus a Quality Control Standard.

#### SPECIFICATIONS AND ORDERING INFORMATION SPECIFY 32 MM OR 40 MM WHEN ORDERING

CAT. NO: PL(PVC)3-5E(D)							
Standard No.	Br, Wt. %	Cd, Wt. %	Cr, Wt. %	Hg, Wt. %	Pb, Wt. %	Ca, Wt. %	Cl, Wt. %
1	0.0000	0.0000	0.0000	0.0000	0.0000	1.5000	15.00
2	0.0500	0.0050	0.0500	0.0500	0.0500	1.5000	15.00
3	0.1000	0.0100	0.1000	0.1000	0.1000	1.5000	15.00
Quality Control Standard	0.0500	0.0050	0.0500	0.0500	0.0500	0.0	35.0

CAT. NO: PL(PVC)9-5E(D)							
Standard No.	Br, Wt. %	Cd, Wt. %	Cr, Wt. %	Hg, Wt. %	Pb, Wt. %	Ca, Wt. %	Cl, Wt. %
1	0.0000	0.0000	0.0000	0.0000	0.0000	0.0	40.0
2	0.1000	0.0100	0.0010	0.0100	0.1000	0.500	35.0
3	0.1000	0.0100	0.1200	0.0150	0.0100	1.500	15.0
4	0.0100	0.0150	0.0750	0.0001	0.0010	0.250	40.0
5	0.0500	0.0075	0.1000	0.0075	0.1500	0.0	35.0
6	0.1500	0.0010	0.0500	0.0010	0.0075	3.0	10.0
7	0.0750	0.0001	0.0100	0.0200	0.0100	0.0	40.0
8	0.0100	0.0050	0.0500	0.0050	0.0500	2.0	12.5
9	0.0500	0.0150	0.0100	0.0050	0.0500	0.0	35.0
Quality Control Standard	0.0500	0.0050	0.0500	0.0500	0.0500	0.0	35.0

Sample Cups  
and Accessories

Thin-Film  
Sample Supports

Grinding Machines  
and Accessories

Briquetting Presses  
and Accessories

Grinding/Briquetting  
Additives

Fusion Machines  
and Accessories

Standards and  
XRF/XRD Chemical Kits

## **AUTOFLUXER® PLUS FUSION MACHINE**

### **AUTOMATIC TEMPERATURE SETTING, MEASUREMENT AND DIGITAL DISPLAY**



Automatically transform powdered samples into “iso formed” vitreous beads for direct XRF analysis or for sample dissolutions in preparation for ICP/AAS analysis.

Matrix, particle and particle-size related differences between samples and standards are eliminated by transformation to the same borate fusion material matrix. The process is amazingly fast and the machine is simple to operate with a small footprint for minimum counter top occupation.

The AutoFluxer® Plus fusion machine is the next advanced generation of the time-proven AutoFluxer Standard Model. It is especially designed for routine analysis, when reproducible melting conditions for various materials with specific fusion parameters are required, independent whether the machine is operating to capacity with full four stations or in between for some single sample on one or two stations only.

# **PROGRAMMABLE Plus More!**

## **Pre-Warming Pre-Melting Agitation Main Melting Cooling Cycles**

### **FEATURES**

- Temperature Display Separate for Each Station in All Process Stages
- Temperature Stability Reproducible Operating with 1 or 2 or All 4 Stations
- Temperature Setting as per Application Program via PLC
- Temperature Ramping for Level 1, 2, or 3 Level Direct
- Separate Mold Heating Independent of Fusion Cycle for Extended Pt Life
- Independent Settings for Swirling, Pouring and Cooling Cycles
- 1+9 Individual Program Recipes with Cycle Times and Temperatures
- PLC Siemens S7 Compatibility
  - Error Messages Display on Programming
  - Display of Gas/Oxygen Running Low
  - Various Interface Connections
  - Multi-Level Password Access

- Sample Cups and Accessories
- Thin-Film Sample Supports
- Grinding Machines and Accessories
- Briquetting Presses and Accessories
- Grinding/Briquetting Additives
- Fusion Machines and Accessories
- Standards and XRF/XRD Chemical Kits

## SpectroCertified® Lithium Borate Pre-Fused FusionFlux™ Formulations



Chemplex Pre-Fused FusionFlux™ formulations are supplied with SpectroCertified technical data on each label for easy referral.

The flux fusion process is an effective and simple method for preparing powdered sample substances for XRF, ICP and AA analysis. The method is based on the dissolution of a sample in conjunction with an appropriate fluxing ingredient at an appropriate temperature. For direct XRF analysis, the molten mixture is cast into glass-like beads or further processed for ICP or AA solution analysis. The most effective fluxing agents are lithium borates as represented by Chemplex SpectroCertified® Pre-Fused FusionFlux™ formulations.

### ATTRIBUTES OF CHEMPLEX SPECTROCERTIFIED® PRE-FUSED FUSIONFLUX™ FORMULATIONS

- High Density:** reduces exceeding the volumetric capacity of crucibles to maintain sample-to-fusion flux ratio recipes and avert the potential possibility of spill over.
- High Purity:** reduces the introduction of potentially influential foreign element contamination by selective control of starting material purity and the pre-fusion process.
- Low Melting Point:** assures the dissolution process at effective temperatures but safely below temperatures of constituent elements considered sensitive to volatility loss.
- Low LOI:** eliminates time consuming accounting for loss on ignition; typically less than 0.03% loss on ignition.
- Anhydrous:** reduces water content and eliminates the conventional procedure of drying prior to use.
- Homogeneity:** ensures compositionally similar constituent particles for homogeneous melts.
- Granulation:** promotes uniform particle size, configuration and distribution by minimizing the introduction of “dust” particles to insignificant levels of concern; typically contain less than 0.05% particles less than 100 microns.
- Diversified Mixtures:** offers the flexibility of selecting from assorted mixtures of different melting points to reduce eutectic melting temperatures of samples and controlling volatile element evolution.
- Free-Flowing:** facilitates handling manually or with automatic dispensing devices.

#### TECHNICAL SPECIFICATIONS

Typical Trace Impurities, PPM

#### Physical Properties

CONCENTRATION, PPM	IMPURITIES, PPM
1	Na, K, Fe, As, Mn, Al, Se, Cd, Pb, Zn, Cu, Ni, Co, Ag, Sn
2	Ca, Mg, Si, S

CAT. NO.	FUSIONFLUX™ MIXTURE	M. P., °C/°F	DENSITY, gm/cc	LOI, %	% PARTICLES <100 μ
30-1000	100% Lithium Tetraborate	920/1688	1.25	<0.03	<0.05
30-2000	100% Lithium Metaborate	845/1553	1.25	<0.03	<0.05
30-3000	80% Lithium Tetraborate 20% Lithium Metaborate	880/1616	1.25	<0.03	<0.05
30-4000	66% Lithium Tetraborate 34% Lithium Metaborate	875/1607	1.25	<0.03	<0.05
30-5000	50% Lithium Tetraborate 50% Lithium Metaborate	870/1598	1.25	<0.03	<0.05
30-6000	35.3% Lithium Tetraborate 64.7% Lithium Metaborate	825/1517	1.15-1.25	<0.03	<0.05

### SPECIFICATIONS AND ORDERING INFORMATION

Supplied in 1 lb (454gm) bottles with Complete Technical Specifications on Labels

CAT. NO.	DESCRIPTION
30-1000	Pre-Fused FusionFlux™ ; Lithium Tetraborate; Li <sub>2</sub> B <sub>4</sub> O <sub>7</sub>
30-2000	Pre-Fused FusionFlux™ ; Lithium Metaborate; LiBO <sub>2</sub>
30-3000	Pre-Fused FusionFlux™ ; 80% Lithium Tetraborate + 20% Lithium Metaborate
30-4000	Pre-Fused FusionFlux™ ; 66% Lithium Tetraborate + 34% Lithium Metaborate
30-5000	Pre-Fused FusionFlux™ ; 50% Lithium Tetraborate + 50% Lithium Metaborate
30-6000	Pre-Fused FusionFlux™ ; 35.3% Lithium Tetraborate + 64.7% Lithium Metaborate

™ FusionFlux is a trademark of Chemplex Industries, Inc.

© SpectroCertified and Chemplex are registered trademarks of Chemplex Industries, Inc.

**PLUS... MORE FEATURES OF THE AUTOFLUXER® PLUS**

- Sample Cups and Accessories
- Thin-Film Sample Supports
- Grinding Machines and Accessories
- Briquetting Presses and Accessories
- Grinding/Briquetting Additives
- Fusion Machines and Accessories**
- Standards and XRF/XRD Chemical Kits

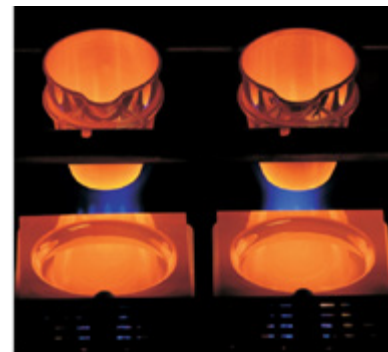
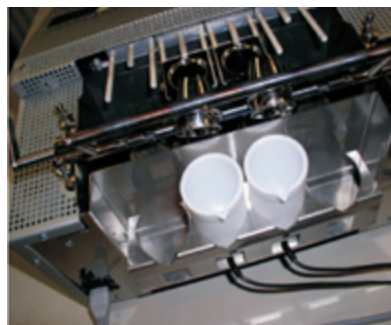

The AutoFluxer® Plus fusion machine is the next advanced generation of the time-proven AutoFluxer® Standard Model; the same small footprint for countertop installation, flexibility for casting beads for XRF analysis and for dissolution of samples for ICP/AAS incorporated into a single machine.

- Mold sensors for each XRF Station, preventing unintended start of melting cycle on a station without a mold in position; takes 32 or 40 mm molds.
- Advanced agitation function designed to ensure effective mixing during the process: circular, slightly vertical, forward and backward, pausing, with time and speed adjustability.
- Automatic and reproducible computer controlled flame temperature setting from 800° to 1650°C accompanied with digital temperature display of each station during the complete process.
- Automatic shut down at over-temperature to protect costly platinum ware and against unintended high temperature settings.
- A simple easy-to-use configuration is designed to effectively self-lock the crucible holder in position eliminating the potential threat of repair or any mechanism or pneumatics that can stop the operation.
- Restricted access capability is programmable to account for different technical levels of operator expertise.
- A defined positioning of the crucible over the burner for melting and pouring the melt into a mold or the center of a beaker for dissolution applications prevents inadvertent mishaps.
- ICP/AAS solution module with up to 4 stations is designed to easily attach to the XRF unit without the use of any tools; the reversible cradle simply snaps together.
- The solution modules have integrated individual speed controlled magnetic stirrers, waterproof, all stainless steel construction with 150 ml PTFE beakers and stirrers.

**SPECIFICATIONS AND ORDERING INFORMATION**

CAT.NO.	DESCRIPTION
32-8000	AutoFluxer® Plus; 8 burners; four stations for producing XRF beads. Includes spare parts kit; 18-1/2" x 18-1/2" x 9.8" (47cm x 47cm x 25cm); 64 lbs (29 kg); 115 VAC/60 Hz and 230 VAC/50 and 60 Hz.
33-1000	Solution Station Base Module for ICP and AAS; one Base Unit plus one speed controlled magnetic stirrer with one magnetic stirring bar and one program chip.
33-2000	Additional Solution Stations for ICP and AA; each additional unit consists of a speed controlled Magnetic stirrer with a magnetic stirring bar.

**REMINDER TO ORDER SPECTROCERTIFIED® FUSION FLUXES**

[CLICK HERE TO RETURN TO FRONT PAGE](#)

**PLATINUM/GOLD ALLOY  
CRUCIBLES AND MOLDS  
FOR AUTOFLUXER® FUSION MACHINES**

- Sample Cups and Accessories
- Thin-Film Sample Supports
- Grinding Machines and Accessories
- Briquetting Presses and Accessories
- Grinding/Briquetting Additives
- Fusion Machines and Accessories**
- Standards and XRF/XRD Chemical Kits



STANDARD STYLE CRUCIBLE AND MOLD

The platinum ware required for the fusion process is a special alloy consisting of an exceptionally high purity of 95% platinum and 5% gold metals. This combination of metals is characteristically suited for the fusion process due to its negative coefficient of fused sample adhesion. Fused sample decanting from the crucible to the mold is virtually free of any lingering droplet at the pouring spout or within the body of the crucible. Removal of thermally set beads is similarly easily performed.

**SPECIFICATIONS AND ORDERING INFORMATION  
Platinum/Gold Crucibles (95% Pt and 5%Au)**

CAT. NO.	DESCRIPTION
40-0025	Standard Style Crucible; 34/20 mm diameter x 38 mm high; 3 holding pins; 0.3mm bottom; pouring spout; approx. 25 gms
40-1041	Supporting Ring with Thick Bottom Crucible; 34/20mm diameter x 38mm high; 3 holding pins at Supporting Ring; 0.5mm bottom; pouring spout; approx. 42 gms
40-2044	Supporting Ring, with Thick Bottom and Reinforced Rim Crucible; 34/20mm diameter x 38mm high; 3 holding pins at Supporting Ring; 0.5mm bottom; reinforced rim with pouring spout; approx. 44 gms.

**Platinum/Gold Molds (95% Pt and 5%Au)**

CAT. NO.	DESCRIPTION
42-2931	Standard Mold; 29/31 mm diameter; 3mm deep; 0.8mm wall thickness; approx. 28 gms
42-3234	Standard Mold; 32/34 mm diameter; 3mm deep; 0.8mm wall thickness; approx. 31 gms
42-3941	Standard Mold; 39/41 mm diameter; 3mm deep; 0.8mm wall thickness; approx. 46 gms

**REMINDER TO ORDER SPECTROCERTIFIED® PRE-FUSED FUSION FLUX FORMULATIONS**

**RECOMMENDED XRF READING MATERIAL**

Sample Cups  
and Accessories

Thin-Film  
Sample Supports

Grinding Machines  
and Accessories

Briquetting Presses  
and Accessories

Grinding/Briquetting  
Additives

Fusion Machines  
and Accessories

Standards and  
XRF/XRD Chemical Kits

**Chemplex<sup>®</sup> INDUSTRIES, INC.**  
2820 SW 42<sup>nd</sup> Avenue, Palm City, FL 34990-5573, USA

Continental USA Toll Free: (800) 4-CHEMPLEX  
Phone: (772) 283-2700  
Fax: (772) 283-2774

Email: [sales@chemplex.com](mailto:sales@chemplex.com) **On Line Sales:** <http://www.chemplex.com>

Bennet, Harry; Oliver, Graham J. XRF Analysis of Ceramics, Minerals and Allied Materials.  
John Wiley & Sons, 1992.

Bertin, Eugene P. Introduction to X-Ray Spectrometric Analysis.  
Plenum Press, New York - London, 1978.

Birks, L.S. X-Ray Spectrochemical Analysis.  
Second Edition, Interscience Publishers, New York, 1969.

Blokhin, M.A. Methods of X-Ray Spectroscopic Research.  
Pergamon Press, New York, 1965.

Burke, Victor E.; Jenkins, Ron; Smith, Deane K. (Eds.). A Practical Guide for the Preparation of Specimens for X-ray Fluorescence and X-ray Diffraction Analysis.  
Wiley-VCH, 1998.

Jenkins, Ron. An Introduction to X-Ray Spectrometry.  
Heyden, London - New York - Rheine, 1980.

Jenkins, Ron. X-ray Fluorescence Spectrometry.  
Second Edition, John Wiley & Sons, Inc. 1999.

Jenkins, Ron; De Vries, Johan Louis. Practical X-Ray Spectrometry.  
MacMillan, London, 1976.

Van Grieken, Rene E.; Markowicz, Andrzej A. (Eds.). Handbook of X-ray Spectrometry: Methods and Techniques.  
Second Edition, Marcel Dekker Inc., New York, 2002.

**DATA BASES**

NIST: National Institute of Standards and Technology

<http://www.cstl.nist.gov/nist839/839.01/index.html>

NIST: Scientific and Technical Databases

<http://www.nist.gov/srd/>

NIST: X-ray Attenuation Coefficients

<http://physics.nist.gov/PhysRefData/XrayMassCoef/cover.html>

X-Ray Periodic Tables

<http://csrri.iit.edu/periodic-table.html>

## X-RAY INSTRUMENTATION MANUFACTURER'S "SHOWCASE"

Sample Cups  
and Accessories

Thin-Film  
Sample Supports

Grinding Machines  
and Accessories

Briquetting Presses  
and Accessories

Grinding/Briquetting  
Additives

Fusion Machines  
and Accessories

Standards and  
XRF/XRD Chemical Kits

The following "Showcase" of instrumentation manufacturers is provided to assist spectroscopists considering the initial purchase or expansion of their laboratory to include new x-ray instruments. The participant companies have provided the necessary information to conveniently establish direct contact by email, phone and fax together with representative instrument images and brief descriptions. Websites are included to further explore their complete product lines and other pertinent information. Be sure to routinely refer to the Chemplex website at [www.chemplex.com](http://www.chemplex.com) to remain abreast of new instrument introductions, technological advancements and participant additions.



### BRUKER AXS, INC.

5465 East Cheryl Parkway  
Madison, WI 53711-5373  
Tel. Toll Free +1 (800) 234-XRAY  
Tel. +1 (608) 276-3000  
Fax: +1 (608) 276-3006  
Contact: [info@bruker.com](mailto:info@bruker.com)  
Website: [www.bruker-axs.com](http://www.bruker-axs.com)



### The new S8 DRAGON™ The Truly Simultaneous XRF Spectrometer for the Metals Industry

The novel S8 DRAGON is the first truly simultaneous X-ray fluorescence (XRF) spectrometer for precise, high-speed elemental analysis for process control in metal production and foundries on the market. It offers high quantitative precision in combination with elemental flexibility for up-to-date production control, covering almost all elements of the periodic table in a single, rapid measurement.

Additionally, it provides:

- Accuracy and precision for process control in metal production
- Ease of use and reliability
- Seamless integration with automation

Check out [http://www.bruker-axs.com/s8\\_dragon.html](http://www.bruker-axs.com/s8_dragon.html) for more product information.



### S2 RANGER with XFlash® LE – Best in class for light element analysis

The combination of the brand new [XFlash® LE detector](#) with 50 W direct excitation power in the S2 RANGER significantly enhances the analytical performance for light elements and eliminates conventional limitations of bench top EDXRF systems for sodium and magnesium. This increase in performance extends the applications range of the S2 RANGER even further.

The S2 RANGER is characterized by its compact "all-in-one" design with integrated pc, printer and vacuum pump minimizing consequently the space requirements. The operational costs of the S2 RANGER are also minimized – no additional vacuum, compressed air or liquid nitrogen is needed. But this not everything: The S2 RANGER is performing elemental analysis in an innovative new way by using [TouchControl™](#). These features make the S2 RANGER the leader in the performance class.



**EASTERN**  
applied research, inc.



**Eastern Applied Research, Inc.,  
Distributor of Xenometrix EDXRF Analyzers  
and Element Xr Systems**

Website: [www.easternapplied.com](http://www.easternapplied.com)

Email: [sales@easternapplied.com](mailto:sales@easternapplied.com)

Phone: 716-201-1115

Eastern Applied Research Inc offers the Xenometrix line of Energy Dispersive X-ray Fluorescence (EDXRF) analyzers to solve a range of material analysis requirements. Xenometrix earned the 2010 Frost & Sullivan's "Global Product Line Strategy of the Year Award in the EDXRF Analyzers Market" for their innovative approach to the technology.

The **EX-6600 Laboratory Spectrometer** is a powerful and versatile EDXRF system. Featuring a patented Wide Angle Geometry optical system the analyzer provides the advantage of both direct and polarized excitation. The overall configuration makes the EX-6600 series a solution for metallurgical, environmental and petrochemical needs. Additional systems include the **X-Calibur**, **X-Cite** and the **portable S-Mobile** series.

For Coating Thickness Measurement needs, Eastern Applied Research offers the **Element Xr line** of equipment. Various detection systems and instrument configurations are available to solve basic single-layer coating applications through complex coating requirements; including multi-layer coatings, composition and plating bath analysis.

Review additional details at [www.easternapplied.com](http://www.easternapplied.com) and contact Application Specialists to discuss an application interest in detail.

## EDAX, INC.

91 McKee Drive  
Mahwah, NJ 07430  
Telephone: (201) 529-4880  
[Info.edax@ametech.com](mailto:Info.edax@ametech.com)  
[www.edax.com](http://www.edax.com)



Orbis Micro-XRF Elemental  
Analyzer with optional viewport

**EDAX**<sup>®</sup>  
Smart Insight

**AMETEK**<sup>®</sup>  
MATERIALS ANALYSIS DIVISION

## The Orbis Micro-XRF Elemental Analyzer

The Orbis micro-XRF elemental analyzer is flexible and easy to use, offering outstanding performance across the complete range of micro-XRF applications. With Orbis, users can choose spot sizes from 2 mm down to 30  $\mu$ m with an easy to use coaxial video/X-ray design to analyze all types of samples. Orbis users can make elemental analyses on small samples such as particles, fragments and inclusions or automated multipoint and elemental analyses on large topographical samples with all the benefits and simplicity of an XRF analyzer. Powerful Vision software provides precise elemental analysis software.



**OXFORD**  
INSTRUMENTS  
*The Business of Science*<sup>®</sup>

*The No. 1 name in XRF*

Complete range of Benchtop and Handheld XRF Analyzers

### Oxford Instruments Industrial Analysis

Contact: [industrial@oxinst.com](mailto:industrial@oxinst.com)

Website: [www.oxford-instruments.com/industrial](http://www.oxford-instruments.com/industrial)

Oxford Instruments named by Frost and Sullivan as the global number one name in the ED-XRF market (2008) offers a wide range of X-ray Fluorescence (XRF) analyzers from light and rugged handheld instruments to laboratory based benchtop systems solving numerous quality control requirements. Find out how Oxford Instruments can help you accelerate your quality control and save you money, whilst improving customer satisfaction. XRF materials testing requires minimal or no sample preparation, rapid non-destructive analysis, ease of use operation by production staff, no potentially dangerous chemicals, PPM to high % concentration range. Sample types analyzed can range from solids, liquids, powders and pastes to grease, films and coatings, etc. All measured with superb accuracy and reliability. That's why we are No. 1!

**X-Supreme 8000, Lab-X3500 and MDX1000** XRF laboratory analyzers span the price/performance range for routine chemical analysis - from Sulfur in petroleum products to the analysis of limestone.

**X-MET** hand-held XRF analyzers are specifically designed for positive material identification, alloy analysis and identification and hazardous material analysis (RoHS). These analyzers are also used to analyze heavy metals in soil on polluted lands and ore at mining sites.



### Rigaku Americas Corporation

9009 New Trails Drive  
The Woodlands, TX 77381

Tel: (281) 362-2300  
Contact: Laura Oelofse  
e-Mail: [info@rigaku.com](mailto:info@rigaku.com)  
Website: [www.rigaku.com](http://www.rigaku.com)



#### Announcing the Rigaku Petro-Pak™ Application Package

Designed to run on select Rigaku WDXRF instruments, Petro-Pak includes installation CD with optimized analytical settings and parameters, calibration data for specific ASTM and ISO methods, drift monitor standards and procedure to keep the method in specification, Validation Certified Reference Materials to independently validate the calibration accuracy, and a Proficiency Testing Program for external validation of your laboratory procedures. The kit includes a starter set of cups and film, and a comprehensive manual that covers installation qualification, operation qualification and performance qualification modules. This information can fulfill the role of standard operating procedures in your laboratory. ASTM and ISO compliant methods are the backbone of our Petro-Pak application package, which is designed to cover the whole range of products manufactured in today's modern refinery.

#### Meet the ZSX Petro, Supermini and Mini-Z Sulfur

Whether you are characterizing the sulfur content of incoming crude oil at weight percent levels or qualifying final product sulfur content for the full product line of gasoline's, diesels, naphtha's, kerosene and jet fuels at single digit PPM levels or weight percent levels of sulfur, one of the Rigaku full service line of XRF spectrometers is your instrument of choice.



**Applied Rigaku Technologies, Inc.**

9825 Spectrum Drive  
Bldg. 4, Suite 475  
Austin, TX USA 78717  
Contact: Mr. Robert Bartek  
email: [info@rigakuedxrf.com](mailto:info@rigakuedxrf.com)  
Tel: +1-512-225-1796  
Fax: +1-512-225-1797

**Elemental Analysis by Energy Dispersive X-ray Fluorescence (EDXRF)**

Applied Rigaku Technologies, Inc. delivers robust tools for rapid qualitative and quantitative determination of major and minor atomic elements in a wide variety of sample types.



**NEX CG Energy Dispersive X-ray Fluorescence Spectrometer**

*Advanced Cartesian geometry EDXRF for rapid qualitative and quantitative elemental analysis*

Unlike conventional EDXRF analyzers, the NEX CG was engineered with a unique close-coupled Cartesian Geometry (CG) optical kernel that dramatically increases signal-to-noise. Sensitivity is further improved by using secondary target excitation, instead of conventional direct excitation. The resulting dramatic reduction in background noise and simultaneous increase in element peaks result in a spectrometer capable of routine trace element analysis even in difficult sample types.

**NEX QC Energy Dispersive X-ray Fluorescence Analyzer**

*New low cost bench top EDXRF for rapid qualitative and quantitative elemental analysis*

As a premium low cost bench top Energy Dispersive X-ray Fluorescence (EDXRF) spectrometer, the Rigaku NEX QC delivers wide elemental coverage with an easy-to-learn software interface in a robust package designed for industrial at-line quality control elemental analysis applications.



**NEX QC+ Energy Dispersive X-ray Fluorescence Analyzer**

*New high resolution bench top EDXRF for rapid qualitative and quantitative elemental analysis*

For more demanding applications, Rigaku offers the new NEX QC+ spectrometer. Featuring a high-resolution Peltier cooled Silicon Drift Detector (SDD) that, together with a 50kV X-ray tube, delivers exceptional short-term repeatability and long-term reproducibility with excellent elemental peak separation. Like the NEX QC, it has an intuitive Smartphone style touch screen interface for easy operation and a built-in printer for convenience.





**SPECTRO Analytical Instruments, Inc.**  
91 McKee Drive

Mahwah, NJ 07430  
Toll Free: 800-548-5809  
Tel: 201-642-3000  
Fax: 201-642-3091

e-Mail: [spectro-usa.sales@ametec.com](mailto:spectro-usa.sales@ametec.com)  
Website: [www.spectro.com](http://www.spectro.com)



**SPECTRO** is a world leader in the manufacture of energy dispersive X-ray fluorescence spectrometers; in recent years it has set standards by further developing this technology and has developed numerous new fields of operation for ED-XRF.

It offers a complete range of ED-XRF products, from handheld, small bench-top instruments for special tasks and multi-purpose laboratory spectrometers to meet any analytical need. Typical uses include the analysis of oils and fuel, plastic, rubber and textiles, pharmaceutical products, foodstuffs, cosmetics and body care products, fertilizers, minerals, ores, rocks, sands, slags, cements, heat-resistant materials, glass, ceramics, wafers; the determination of coatings on paper, film, polyester and metals; the sorting of metal alloys, glass and plastic according to their constituent materials; and the monitoring of solid waste, effluent, cleaning fluids, pools and filters.



To know more,

Visit: [www.thermoscientific.com/performx](http://www.thermoscientific.com/performx)

Contact us at: [analyze.us@thermo.com](mailto:analyze.us@thermo.com)

Telephone (Toll Free): 1-800-532-4752

Whether guaranteeing tighter process specs or accelerating new product development, - discover :

## **NEW Thermo Scientific ARL PERFORM'X Advanced WDXRF Spectrometer**

Provides Speed, Reliability and Analytical Precision for Organic and Inorganic Elemental Analysis

Sample Cups  
and Accessories

Thin-Film  
Sample Supports

Grinding Machines  
and Accessories

Briquetting Presses  
and Accessories

Grinding/Briquetting  
Additives

Fusion Machines  
and Accessories

Standards and  
XRF/XRD Chemical Kits

## Chemplex® XRF Sample Cups, Thin-Film Sample Support Windows and Microporous Polypropylene Film Comply with RoHS



The awareness of environmental and hazardous issues has gained momentum and has substantially increased. With growing concern for the environment regarding disposal and recycling of plastic and polymer products containing specific substances, restrictions have been imposed for compliance.

This restriction, commonly referred to as ROHS, imposes a Restriction of Hazardous Substances. It specifies and directs compliance in accordance with not to exceed the following standards:

Lead ( <b>Pb</b> )	0.1 % (1000 PPM)
Cadmium ( <b>Cd</b> )	0.01% (100 PPM)
Mercury ( <b>Hg</b> )	0.1% (1000 PPM)
Chromium ( <b>Cr</b> ); hexavalent chromium (VI)	0.1% (1000 PPM)
Polybrominated Biphenyl; <b>PBB</b>	0.1 % (1000 PPM)
Polybrominated Diphenyl Ether; <b>PBDE</b>	0.1 % (1000 PPM)

Note: PBB and PBDE are flame-retardants formulated in a number of plastics.

RoHS is the beginning of a global trend as consumer and environmental interests become more intensified. Some of the world's other prime economic regions are in the process of adopting similar restrictions.

### The Current 25 Member States of the European Union (EU)

Austria, Belgium, Czech Republic, Cyprus, Denmark, Estonia, Finland, France, Germany, Greece, Hungary, Ireland, Italy, Latvia, Lithuania, Luxembourg, Malta, The Netherlands, Poland, Portugal, Slovakia, Slovenia, Spain, Sweden, United Kingdom (Great Britain).

As consumer and environmental interests become more intensified, RoHS appears likely to be the beginning of a global trend. Some of the world's other prime economic regions, including China and Taiwan, are in the process of enacting similar directives or laws and the geographic market for non-compliant products is dwindling.

### Chemplex® Commits to Comply with the European Council Directive, RoHS

Chemplex Industries, Inc. is demonstrating a continuing commitment to environmental responsibility and is a major voluntary participant in complying with the European Council Directive 2002/95/EC, RoHS. The stylized symbol Chemplex Industries, Inc. has decided to adopt for demonstrating environmental responsibility and compliance to RoHS is illustrated as follows:



When purchasing XRF Sample Cups, Thin-Film Sample Support Windows and Microporous Polypropylene Film for use within the USA or for export to the European Union (EU), in addition to other countries intending to adopt similar Directive enactments, look for and insist on this symbol to be assured of compliance and acceptance by the European Council and Directive. It's environmentally responsible.

## XRF TECHNICAL REPRINTS

Sample Cups  
and Accessories

Thin-Film  
Sample Supports

Grinding Machines  
and Accessories

Briquetting Presses  
and Accessories

Grinding/Briquetting  
Additives

Fusion Machines  
and Accessories

Standards and  
XRF/XRD Chemical Kits

In developing the Chemplex product line, a great deal of experimentation was necessary to perform in order to ascertain the suitability of the product to its intended use and applications.

In some instances, this information was compiled and submitted to various trade journals for publication to illustrate and disseminate the methodology employed to arrive at the results. Reprints of the published articles are contained in this section for perusal in the belief that they will provide a benefit to the analyst in evaluating a product to relevant sample material preparations.

[“Disposable Sample Cups for X-Ray Fluorescence Analysis”](#) illustrates the research and development of XRF sample cups for containing invariable sample substances under various environmental conditions. It discusses and exhibits the first sample cup developed at a time when x-ray spectroscopy was entering the market as a very functional tool for analyzing innumerable types of sample substances in the petrochemical field. The evolution of the present day sample cups are easily recognized as the needs of the analyst expanded to include virtually any type of sample substance for quantifying an ever increasing number of elemental constituents in lower concentrations and to lower limits of detectability in less integration time.

Closely coupled to the development of consumable XRF sample cups was the necessity to compile data relevant to the thin-film substances that were available for containing various types of sample materials. This involved elaborate testing on the limited types and gauges of thin-film materials that were available and forming meaningful correlations for suitability of use. This also prompted the exploration of new thin-films as potential candidates with technological advancements in instrumentation. This is illustrated in [“X-Ray Fluorescence Thin-film Sample Support Materials”](#). Obviously with the passage of time, increased types and gauges of thin-films were investigated and improved mass attenuation coefficient values became available to better qualify thin-film substances.

The preparation of sample substances generally classified as powders represented another grouping of samples that warranted further investigation. This was particularly important in regard to the need to improve uniform particle size reduction and homogeneous distribution throughout the sample aliquot for greater analytical accuracy and precisions of measurement. Two basic concepts of comminution were examined: vigorous ball pestle impact on a powdered sample substance contained in various grinding media and controlled energetic gyratory impact of grinding media on a sample substance. The data derived from this experimentation lead to the development of the Chemplex SpectroMill® Ball Pestle Impact Grinder and the Chemplex GyralGrinder® Comminution Device. These published articles are respectively entitled [“An Investigation of the Performance of Comminution Vials and Ball Pestle Impact Grinders”](#) with respect to the SpectroMill, and [“A Comminution Device for X-Ray Spectrochemical Analysis,”](#) representing the GyralGrinder.

**Note:** In some instances, photographs and more elaborate presentations were replaced to reflect the most recent findings without distorting the actual published conceptual content and methodology.

Reprinted from American Laboratory, November 1984

By Dr. Monte J. Solazzi



# Disposable sample cups for X-ray fluorescence analysis

**T**ECHNOLOGICAL advancements in both wavelength-dispersive (WDXRF) and energy-dispersive (EDXRF) x-ray fluorescence instrumentation have given the spectroscopist the means to accommodate virtually all types of sample materials. Higher degrees of analytical accuracy and precision and lower limits of detection and concentration levels can be achieved. As a result, refinements in sample presentation methods have been made and, in many instances, new systems and adjunct equipment have been introduced. Sample analysis times decreased dramatically, and x-ray fluorescence is now recognized as a versatile laboratory tool useful for both infrequent and routine sample analysis.

Sample preparation is frequently more time-consuming than the actual analysis. This is particularly true with powdered solid sample materials as a result of the need to reduce sample particle size differences and inhomogeneities to insignificant levels. Solution samples, in most cases, simply require transfer to an appropriate device for containment and presentation to the instrument. Unlike powdered solid or solid samples, the constituent elements in solution samples are assumed to be in complete states of dissolution: as long as the laws governing critical depths of penetration are observed, no further processing is usually required.

This paper describes a line of disposable plastic XRF sample cups (Chemplex® Industries, Inc.) for use with powdered solid, liquid, and solid sample retention. The cups are used to present samples for x-ray fluorescence analysis, and contribute to efficiency in sample handling methods and diversification of applications.

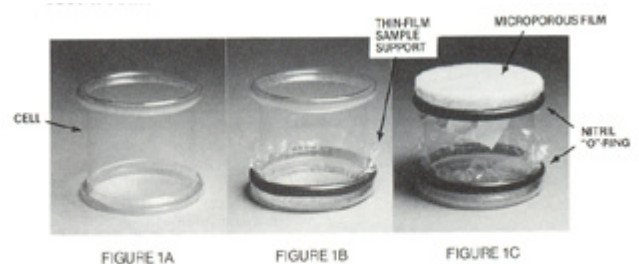

Figure 1 Dispoza-Cups.

## Product Development

The first Chemplex disposable x-ray fluorescence sample cups were called Dispoza-Cups. The body, or cell, of the cup shown in Figure 1a, was fabricated of tubular cellulose acetate butyrate cut into appropriate lengths to fit into metallic sample holders on the instrumentation. The ends of the cell were thermo mechanically turned down and under to form smooth, rounded beads to which thin-film sample supports with nitrile O-rings were affixed (Figure 1b). A conically shaped aluminum device was designed to stretch the nitrile "O"-ring as it was guided to roll over the beaded edge of the cell to effect a seal.

Dispoza-Cups were useful in eliminating time consuming and costly clean-up operations, and for reducing the possibility of cross contamination. Their use and applications were mainly in the oil and petrochemical industries. Significant drawbacks prohibited their use in effectively retaining the types of sample materials normally conducive to x-ray fluorescence analysis. The cellulose acetate butyrate material did not offer adequate resistance to chemical attack and degradation or softening from intense energy source excitation. Also, since the cell end obverse to the thin-film sample support was open, analyses of many types of sample materials were limited to applications in air or inert gas environments. To resolve the difficulties associated with pressure inequalities, a gas-permeable, chemically unreactive polypropylene membrane, called microporous film, was used as a cover for the open end of the Dispoza-Cup, and was attached similar to a thin-film sample support with a nitrile "O"-ring (Figure 1c).

Microporous film is characterized by 0.1mm channels (35% porosity) that permit the permeation of gaseous-size molecules, while at the same time prohibiting the penetration and withdrawal material from the cell. Microporous film maintains continuous equalization of pressure within the sample cup and sample chamber, thereby averting potential distention or retraction of the thin-film sample support and subsequent alteration of the sample-to-excitation source distance. The use of other plastic materials was then investigated, and a complete cell design change was made that incorporated a type of clamping ring to firmly and easily secure a thin-film sample support. Injection molding was found to be the best method for manufacturing sample cups in volume, a procedure that was adaptable to a large variety of thermoplastic materials.

Fifteen different disposable XRF sample cups are currently available for use with a wide range of commercial x-ray spectrochemical analyzers. The cups are made of polyethylene, which is resistant to chemical degradation, deterioration by excitation of source exposure, and thermal softening by x-ray bombardment. Polyethylenes also resists thin-film distortion during and after assembly, is elastic or ease in firmly securing thin-film sample supports without formation of pinholes, and is pure, particularly with regard to sulfur content.

#### Thin-Film Sample Support Attachment

The design of the cell neck on Chemplex XRF sample cups, in conjunction with the snap-on ring, retains the thin-film sample support in position and maintains it continuously taut up to the completion of assembly. Figure 2 shows the mechanism responsible for effective thin-film sample support preparations. One end of the snap-on ring (Figure 2a) has a semi-spherically shaped "bead" around the interior circumference. Below the bead, the diameter decreases toward the opposite end to form a taper on the inside of the snap-on ring. The cell neck (Figure 2b) has a similar taper on the outer diameter that increases beginning from the edge and extending toward a semispherical indentation around the circumference. The inside diameter of the bead is slightly larger than the outside diameter of the cell neck at the edge. Extending a small distance from the cell neck edge, the bead of the ring meets resistance to further assembly from the increasing cell neck taper.

Thus the thin-film sample support material is initially grasped and held taut at all points of contact by the bead and is temporarily stretched (illustrating the need for thermoplastic elasticity) until the bead finally locks into the cell neck (Figure 2c). The thin film sample support thus formed is leak-resistant, wrinkle-free, and taut, reducing the chance of contamination.

The distances from the cell neck edge to the indentation, and from the bead to the opposite end, are slightly dissimilar; the ring extends a slight distance beyond the cell neck. The difference in length prevents the sample support from contacting the surface preparation area and introducing contamination or accidental puncturing. In addition, the snap-on ring will not fit the cell neck unless positioned properly.

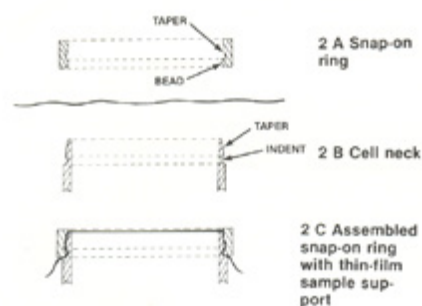

Figure 2 Cross-sectional illustration of snap-on ring and cell neck configurations.

## Open cell 1500 XRF sample cups

The 1500 Series XRF sample cups, the successors to the Dispoza-Cup, consist of a cell open at both ends and two identical snap-on rings (Figure 3). The ends of the cell incorporate tapered and beaded snap-on rings for attachment of thin-film sample supports, microporous film, and the 1600 Series sample cup caps. A ridge at the outer circumference adjacent to the indentation at one end of the cell shows which is the appropriate side for installing microporous film. As a general rule, microporous film and sample cup caps are attached to the ridged end of the cell, and thin-film sample supports are secured to the opposite end.

A thin-film sample support is positioned over the cell, and a snap-on ring is placed on it and pushed downward to complete assembly, as indicated by a clicking sound. The cell is inverted and a sample is introduced through the top open end and presented for analysis. To avoid spillage during handling or analysis, the open top end of the cell is covered using either microporous film with a second snap-on ring or a 1600 Series sample cup cap. Some analysts reported use of a thin-film sample support on the open top end, but this is not recommended because of significant pressure differentials that may affect the excitation source-to-sample distance or cause a thin-film rupture.

The 1500 Series cups are available in 32 mm (12 ml sample capacity) and 40 mm (18 ml capacity) diameters, 23 mm in height. The aperture (inside diameter of the cell measured at the opening) is 25 mm and 32 mm respectively for the two sizes. Translated into sample surface areas available for analysis, the 32 mm cups provide 493 mm<sup>2</sup> and the 40 mm cups 807 mm<sup>2</sup>.

## Sample Cup Caps

The 1600 Series XRF sample cup caps are used with the open cell sample cups. The caps maintain continuous equalization of pressure between the sample cup and sample chamber concurrent with sample containment.

Sample cup caps, when assembled to a 1500 Series sample cup (Figure 4), are designed to keep a specimen from escaping. The underside of the cap contains a trough between a circular baffle adjacent to an outer circumferential ring. The inside surface of the outermost ring has a semi spherically shaped bead that mates with the indentation in the cell neck. The flat plane of the sample cup cap contains four narrow slits that coincide with the circular narrow trough. When the cap and cup are assembled, the cell neck positions itself in the trough, leaving a narrow passageway to the slits for pressure equalization. The winding passageway prevents material from escaping.

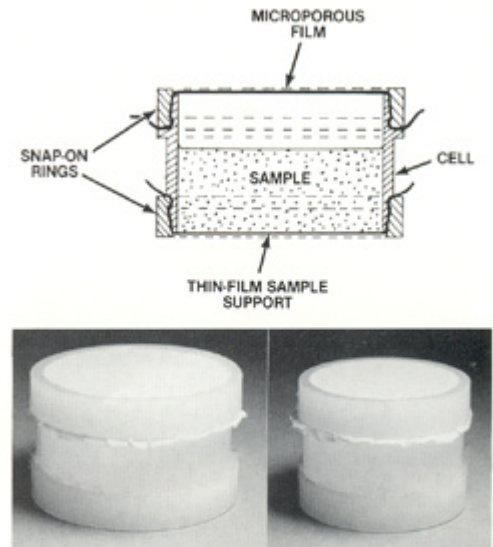

Figure 3 Diagram and photograph of open-cell sample cups.

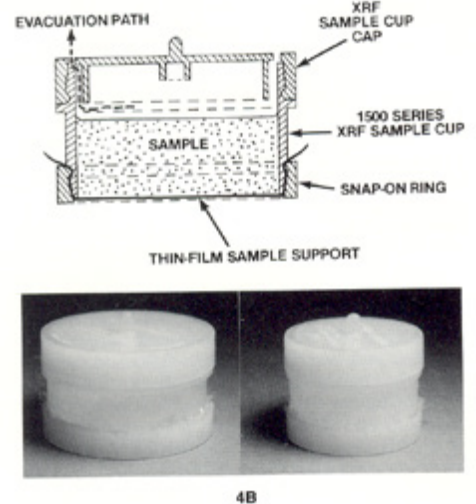
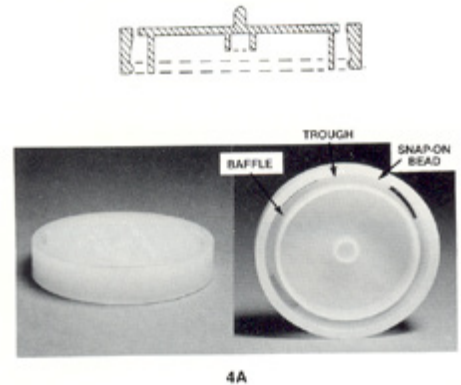

Figure 4 Diagram of XRF sample cup cap.

## Closed Cell Sample Cups

The 1400 Series closed cell XRF sample cups\* (Figure 5) are thermo plastically sealed at one end during the injection molding process and incorporate special features that enhance their versatility.

As with all Chemplex XRF sample cups, the design for the closed-cell cups includes the thin-film sample support "clamping" method for attachment. The closed outside end contains two small circular depressions that are for vent-holes for pressure equalization purposes. One vent-hole is centrally located and the other is off-center. Both are sealed during the injection molding process and can be easily ruptured by a blunt instrument or an automatic vent-hole punch, supplied as an accessory, for establishing pressure equalization. For routine applications, the cell is filled with a sample material and a thin-film sample support is attached with a snap-on ring. The assembled cup containing the sample is inverted and the central vent-hole seal is punctured to establish pressure equalization in air, helium, or vacuum atmospheres.

For special applications, the underside of the closed end contains a receptacle in the center directly opposite the exterior center vent-hole provision (Figure 6) for insertion of a capillary tube or rod to which a micro sample or internally positioned reference material may be attached. The inside diameter of the receptacle is 4 mm, and the receptacle is slightly tapered to accept and firmly retain a rod or capillary tube of similar outside diameter. Different lengths of rod or capillary tube can be used. The off-center vent-hole serves to equalize pressure in applications using the built-in central receptacle. The secondary function of the receptacle is to reduce sample escape during evacuation and to impede the flow of oil-type specimens, which tend to adhere and creep along a surface,

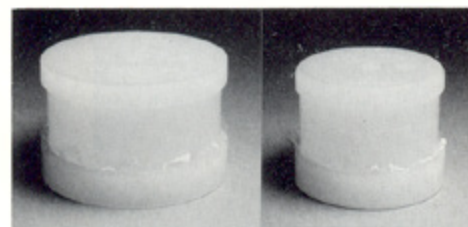
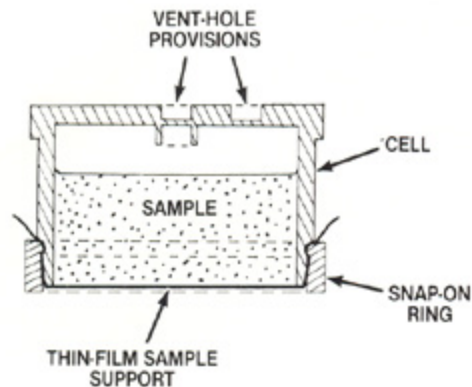

Figure 5 Diagram of 1400 Series XRF sample cups.

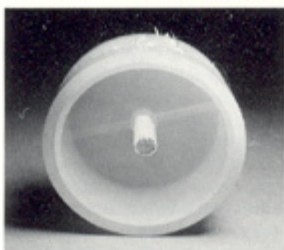
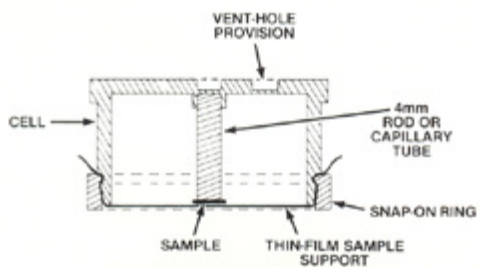

Figure 6 Diagram of 1400 Series cup with microsample mounting feature.

The 1400 Series cups have a collar that entraps or "sandwiches" powdered solid or evaporated liquid specimens between two pieces of thin film (Figure 7). The collar is first introduced to attach a thin-film substrate to the cell; the specimen is deposited on the substrate, and a second thin-film sample support is secured directly over this with a snap-on ring, thereby entrapping the specimen. A third piece of thin film is frequently used to uniformly spread or distribute sandwiched powdered solid sample, to encompass as much surface area as the quantity of specimen allows. The collar is also used to position a sample-impregnated filter paper prior to final assembly with a snap-on ring. Many users initially position a thin-film sample support with a collar prior to final assembly with a snap-on ring, as an added convenience. Closed cell cups are available in 32 and 40 mm diameters with volumetric capacities of 12 and 18 ml respectively, the sample exposure or excitation impingement area is 493 mm<sup>2</sup> for the 32-mm size and 807 mm<sup>2</sup> for the 40-mm version, both sizes are 23 mm in height.

## Sample Cups for Heat-Sensitive Liquid Samples

The 1800 Series XRF sample cups (Figure 8) accommodate heat-sensitive liquid samples that tend to expand when subjected to intense irradiation or reduction in atmospheric environment. The top end of the closed cell has an overflow reservoir to collect and retain thermally expanded sample materials or oil specimens, which are characterized by their tendency to "creep," and which may escape through the punctured vent-hole. The 1800 Series sample cups have all of the features of the 1400 Series cups, with the exception of the interior receptacle for micro sample mounting. The cups have snap-on rings and collars for thin-layered sandwiched evaporated liquid or powdered solid sample preparations.

Two sizes are available: 32 mm and 40 mm diameters. The 32 mm size accommodates 7 ml of sample material, and the overflow reservoir accepts up to 3 ml. The 40 mm cup will contain 12 ml of sample, with an overflow reservoir of 5 ml. The 32 mm diameter cup exposes 493 mm<sup>2</sup> of sample surface area for analysis, and the 40 mm size exposes 807 mm<sup>2</sup>. Both are 23 mm in height.

## Specially Designed Sample Cups

Requests from spectroscopist and x-ray fluorescence instrumentation manufacturers have led to the development of specially configured XRF sample cups, all incorporating the "clamping" method of thin-film sample support attachment.

The 1850 Series disposable, polyethylene XRF sample cup (Figure 9) is designed for use with Horiba SLFA Series instrumentation. The cup features a vent-hole for pressure equalization, an overflow reservoir of 6 ml capacity, and a cell that contains 15 ml of sample. The outside diameter of the 19-mm-high assembled unit is 47 mm. The aperture of the 1850 sample cup is considerably larger in diameter-36 mm-than other cups, and permits a sample exposure area of 1022 mm<sup>2</sup>. This sample cup is not limited to use with Horiba instrumentation. Many analysts have found the large sample exposure area beneficial in decreasing the influence of powdered solid sample surface irregularity on x-ray data and in reducing integration time. The instrument, however, must be able to accept a sample at least 50 mm in diameter.

Instruments manufactured by Oxford Analytical require disposable sample cups 37 mm in length to accommodate the long depth of excitation source penetration and to avoid impingement with the sample cup. Two disposable sample cups were developed for Oxford Lab-X spectrometers. The 1440-L cup has a closed cell and the 1540-L is open on both sides, with one end containing a slight ridge for convenience of handling. The closed 1440-L cell has a vent-hole provision for pressure equalization. Both cups are 37 mm long and 40 mm in diameter, with volumetric capacities of 25 ml and a sample surface exposure area of 493 mm<sup>2</sup>.

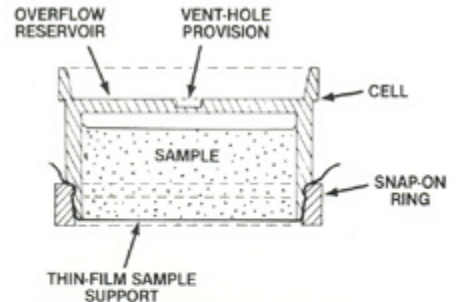

Figure 8 Diagram of 1800 Series cup with overflow reservoir.

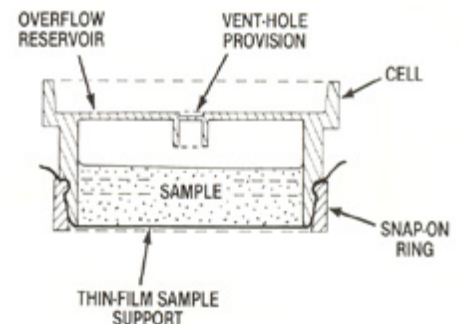

Figure 9 Diagram of 1850 Series cup, 47 mm in diameter.

### Convertible Closed/Open cell Sample Cups\*\*

Another unique sample cup design is a convertible closed/open cell (Figure 10). The cup consists of a snap-on ring for attaching a thin-film sample support, an open cell, and a leak-resistant snap-on cap for insertion into the upper open end, thereby converting the open cell to a closed version. The snap-on cap is secured to the cell by the bead and indentation design and can be rotated by force.

A small cutaway in the snap-on cap at the circumference corresponds to a vertical groove in the inside cell wall that extends a short distance to the upper surface. When these are fitted together, an unobstructed passageway from the interior of the cell is established for pressure equalization. Misalignment of the cutaway with the vertical groove converts the cell to a closed unit (Figure 10b).

In practice, the snap-on cap is first inserted in place in a sealed position. The cell is inverted and a liquid or powdered solid sample is introduced, followed by attachment of a thin-film sample support. Prior to analysis, the cap is rotated to the appropriate position for pressure equalization. An overflow reservoir built into the snap-on cap collects heat sensitive liquid samples that may expand as a result of heat generated by intense excitation; This XRF sample cup style is available in 32 mm and 40 mm diameter sizes, both 23 mm in height. The 32 mm cup exposes 493 mm<sup>2</sup> of sample area, and the 40 mm version exposes 807 mm<sup>2</sup>.

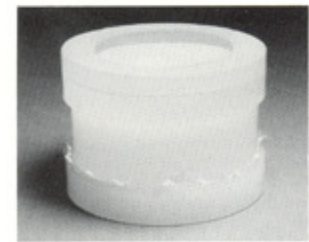
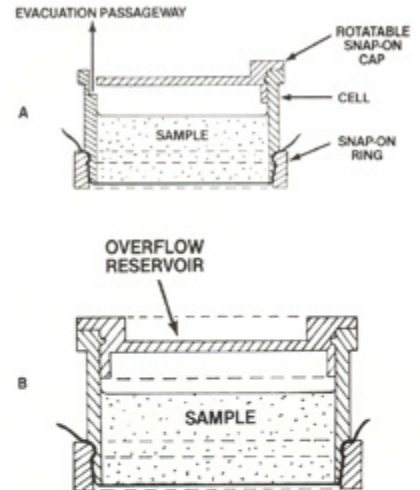

Figure 10 Diagram of convertible closed-open cell cups.

### Push-Plunger\*\*\*, Self-Venting XRF Sample Cups

A disposable XRF sample cup similar to the 1400 Series features a grooved plunger attached in the center to the closed end of the cell (Figure 11). The plunger punctures the thermoplastic seal to equalize pressure within the sample cup and its external environment. This cup features an overflow reservoir; other specifications are similar to those for the 1400 Series cups, including availability of both 32 mm and 40 mm diameter sizes.

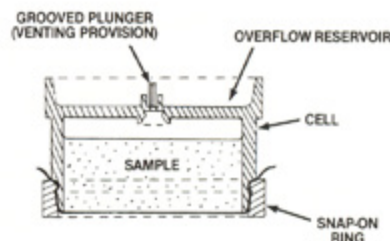

Figure 11 Diagram of push-plunger XRF sample cup.

## Thin-Film Sample Supports

As the range of elemental detect ability to lower atomic numbers and concentrations has been extended, the need for thin-film sample supports characterized by greater analyte-line transmittance properties and greater sample retention strength has also increased. Polyethyleneterephthalate (Mylar®), available in 6.3, 3.6, and 2.5  $\mu\text{m}$  gauges, together with 6.3  $\mu\text{m}$  XRF polypropylene film and 7.5  $\mu\text{m}$  polyimide (Kapton) thin-films, give analysts a range of sample supports for a variety of needs. Figure 12 shows the relative percent transmittance for each thin-film sample support material and gauge to analyte-line wavelength up to 14 Angstroms.

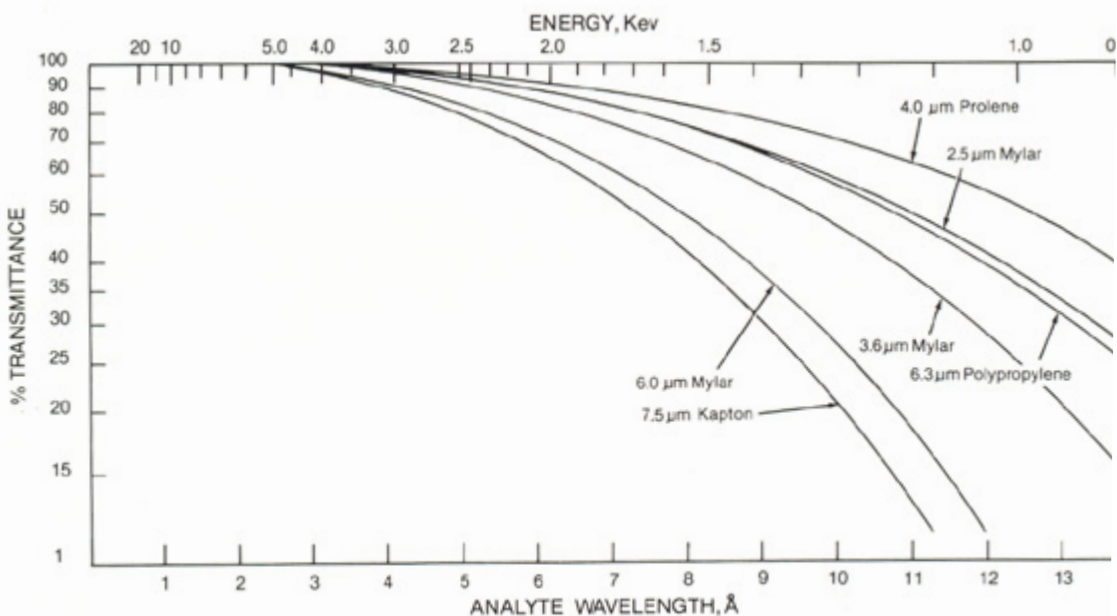

Figure 12 Relative percent transmittance and gauge for thin-film sample support material

## Summary

A broad range of disposable XRF sample cups have been described that were developed in response to advances in WDXRF and EDXRF instrumentation. The cups aid in sample handling and increase efficiency. The cups feature a unique tapered snap on ring with a bead and indentation assembly that clamps the thin-film sample support. Supports come in a variety of materials and gauges.

XRF sample cups are manufactured in the United States in a range of styles, sizes, and specialized features, and can be shipped on the day of order. Engineering expertise, tooling, and supporting equipment are available at the manufacturer to accommodate the special needs of instrumentation manufacturers and users for quality XRF sampling accessories.

Dr. Monte J. Solazzi is President, Chemplex® Industries, Inc., 2820 SW 42<sup>nd</sup> Avenue, Palm City, FL 34990, USA. Tel: (772) 283-2700.

Dispoza-Cup is a trademark of Chemplex Industries, Inc.

\* Registered US Patent Number 238,693

\*\* Registered US Patent Number 4,698,210

\*\*\* Registered US Patent Number 4,409,854

Reprinted from **American Laboratory**, 17 (11) November 1985

By Dr. Monte J. Solazzi

# X-ray fluorescence thin-film sample support materials

Figure 1.  
Thin-Film Sample Support Materials

**T**HE RETENTION of liquid, powdered solid, solid, and slurry samples in disposable XRF Sample Cups (Chemplex<sup>®</sup> Industries, Inc.) in preparation for energy- (EDXRF) and wavelength-dispersive (WDXRF) x-ray fluorescence (XRF) spectrochemical analysis has been previously described<sup>1</sup>. This report describes the various types of sample cups available, some advancement in thin-film materials and the parameters used to assess them, and illustrates the influence of these materials on analyte-line transmittance.

Since the inception of WDXRF and EDXRF instrumentation, rapid technological developments have extended the range of analytical interest to lower atomic number elements, lower limits of detection, and diversified scientific disciplines, thus necessitating thin-film sample support materials more reproducible in gauge thickness and providing higher analyte-line transmittance.

A substance used in thin-film sample supports must exhibit a relatively high degree of resistance to chemical attack, excitation energy source, embrittlement or degradation, thermal softening, and deterioration from the heat generated by excitation exposure, and possess relatively good sample retention strength. The materials must also be reasonably free of impurities and possess the necessary combination of chemical composition, density, and gauge to impart minimum absorption of both the primary (excitation energy) and secondary (analyte-line) radiation.

Until 1972, the most commonly used thin-film sample support material was 6.3  $\mu\text{m}$  gauge polyethylene terephthalate (Mylar<sup>®</sup>). Later, 2.5  $\mu\text{m}$  and 3.8  $\mu\text{m}$  gauges were introduced. These three gauges together effectively accommodated virtually all areas of analytical interest, but due to a change in the manufacturing process of Mylar, trace quantities of Ca, P, Sb, and Zn were detected. Converting to a different grade of Mylar reduced the concentration of these elements, and two of the gauges were substituted with 3.6 and 6.1  $\mu\text{m}$  gauges. In addition, three polymeric materials-polypropylene, polyimide, and polyethylene-qualified as thin-film sample supports and were found to be relatively free of potentially interfering impurities.

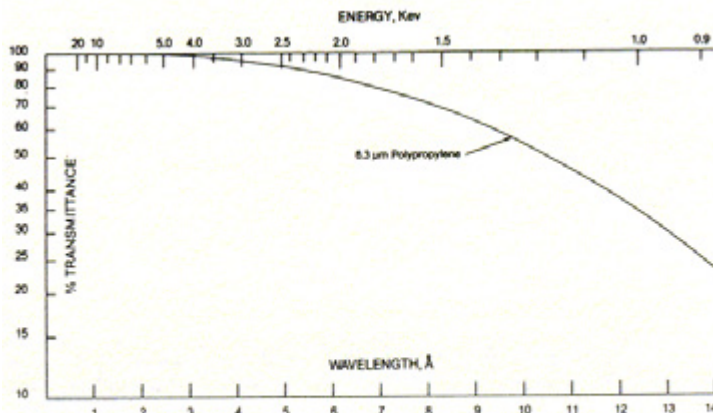

**Figure 2** Analyte-line correlation to percent transmittance.

Initially, a suitable polypropylene was difficult to locate since a specific biaxially oriented type was required to avoid stretching. Thin-film supports must resist stretching and subsequent random alteration of gauge thickness and variations in analyte-line transmittance. X-ray polypropylene (Chemplex Industries, Inc.) was later offered in a 6.3 μm gauge as a replacement for Mylar. Although 6.3 μm gauge polypropylene resulted in a 5.4% decrease in analyte-line percent transmittance in comparison to the 2.5 μm gauge Mylar at 12.4 Angstroms, only a slight increase in integration time was required. Polyimide (Kapton®) in 7.6 μm gauge was also offered for specialized applications requiring increased sample retention strength for the more active analyte-line investigations and for vacuum applications. These thin-film sample support materials are shown in Figure 1.

The suitability of a substance for use in thin-film sample supports depends on its ability to permit analyte-line transmittance. This property is determined from the total mass attenuation coefficient of the material in combination with its area concentration for a given analyte-line, obeying Lambert's law in accordance with the following formula:

$$I = I_0 \exp [-(\mu/d) dt]$$

Where,  $I$  = incident intensity;

$I_0$  = transmitted intensity;

$\mu/d$  = mass attenuation coefficient,  $\text{cm}^2/\text{g}$

$dt$  = area concentration,  $\text{g}/\text{cm}^2$

This relationship shows the dependence of analyte-line transmittance on thin-film chemical composition, density, and thickness:  $(\mu/d)(dt)$ . Since the total mass attenuation coefficient of a thin-film material for a specific analyte line is based on the sum of its elemental constituent values, the chemical composition of the substance is critical and determines suitability for this application.

Rearrangement of the equation to express the percentage of incident and transmitted radiation,  $I/I_0$ , as a function of mass attenuation coefficient, density, and thickness,  $\exp [-(\mu/d)(dt)]$ , provides a visual presentation of analyte-line transmittance through the thin-film substance.

Figure 2 demonstrates the reduction in percent transmittance with increased analyte-line wavelength (decreased keV values) for 6.3 μm gauge polypropylene. The effect of thin-film thickness on analyte-line transmittance is illustrated in Figure 3. The curves represent the percent analyte-line transmittance relationship for the same thin-film substance. (Mylar was arbitrarily chosen as the test material.) The displacement of the curves from one another is attributed to gauge differences. Note that absorption effects predominate in the long wavelength (low keV) region; the more energetic analyte lines tend to penetrate a thin-film substance with very little resistance as transmittance approaches 100%.

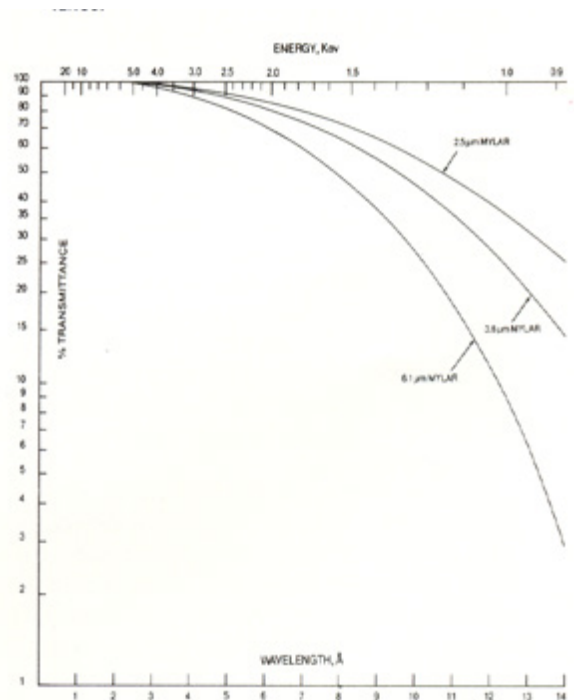

Figure 3 Analyte-line transmittance as a function of substance and gauge.

Other thin-film substances and gauges have been similarly assessed. The resultant curves differ completely from one another in individual combinations of mass attenuation coefficient, density, and gauge relationships. By constructing a series of superimposed curves encompassing a variety of thin-film substances and gauges, a rapid and effective visual means is established for selecting the most applicable thin-film material and thickness for specific analyte investigations (see Figure 4). However, other influential variables—the properties more directly associated with sample retention—are equally significant to thin-film material and gauge selection.

## Degradation Resistance

A thin-film substance is also assessed by properties jointly classified as "degradation resistance." Degradation resistance as defined here represents the ability of a thin-film material to safely retain a specimen in an XRF sample cup during preparation and analysis. Degradation resistance includes resistance to chemical attack, thermal softening, embrittlement, tearing, and stretching.

The immediate chemical attack on a thin-film substance by contact with a specimen is usually obvious. However, deterioration is not always so evident: it may worsen with time or by heat induced from excitation, embrittlement from excitation energy exposure, or a combination of these and other events.

Although it is important to use the thinnest possible gauge thin-film substance to maximize analyte-line transmittance, very thin gauges tend to increase the threat of rupture under the weight of the specimen or under pressure differential created when the sample being analyzed is contained in a sealed sample cup in vacuum. A substance characterized by relatively high tensile strength is required. The tensile strength associated with most polymeric substances described is almost equal to 5000 psi. The thickness of the film then becomes the principal governing factor for sample retention strength.

A thin-film material must also resist stretching. Any changes associated with the thickness of a thin-film material are reflected by the degree of analyte-line transmittance and its influence on analytical accuracy. Any stretching of a thin-film material upon attachment to a sample cup will be reflected in the analytical data. Under vacuum, a differential in pressure between a sealed sample cup and the optics will cause the thin film to distend, creating two problems: a decrease in the distance from the excitation source to sample plane (defined by the thin-film sample support surface plane), resulting in false higher intensity measurements and analyte concentrations, and a decrease in the thickness of the thin film by stretching, resulting in an increase in analyte-line transmittance, thus implying a higher analyte concentration than actually exists.

In assessing thin-film substances, little information was available relating analyte-line transmittance and degradation resistance properties. Chemical and physical characteristics are generally expressed in terms of tensile strength, elongation, tensile modulus, tear strength, type of substance related to diversified and extended time and temperature exposures—all of which leave interpretation and evaluation to the spectroscopist for thin-film sample support applications.

A substance-screening procedure for thin-film applications that assigns a rating value combining degradation resistance and analyte-line percent transmittance properties emerged based on two criteria: failure of a single critical property or a combination of less critical individual properties. Substances were classified as good, fair, or poor (Table 1) and were related to chemical classifications as a common denominator for ease of referral and comparison instead of the conventional chemical material listings traditionally provided in chemical classifications.

A substance-screening procedure for thin-film applications that assigns a rating value combining degradation resistance and analyte-line percent transmittance properties emerged based on two criteria: failure of a single critical property or a combination of less critical individual properties. Substances were classified as good, fair, or poor (Table 1) and were related to chemical classifications as a common denominator for ease of referral and comparison instead of the conventional chemical material listings traditionally provided in chemical classifications.

Table 1  
Degradation Resistance of Thin-Film Substances

Chemical Classification	Mylar®	Polycarbonate	Etnom®	Polypropylene	Polyimide (Kapton®)	Prolene®	Ultra-Polyester®
Acids, dilute or weak	G	G	G	E	N	G	G
Acids, concentrated	G	G	G	E	N	E	G
Alcohols, aliphatic	N	G	G	E	G	E	N
Aldehydes	U	F	F	E	E	E	U
Alkalis, concentrated	N	N	G	E	E	E	N
Esters	N	N	F	G	G	G	N
Ethers	F	N	F	N	U	N	F
Hydrocarbons, aliphatic	G	N	E	G	E	G	G
Hydrocarbons, aromatic	N	N	E	N	E	N	N
Hydrocarbons, halogenated	F	N	F	N	F	N	F
Ketones	N	N	G	G	G	G	N
Oxidizing Agents	F	N	F	F	N	F	F

E = Excellent, G = Good, F = Fair, N = Not Recommended, U = Unknown

**NOTE:** The information contained in the above illustrations is provided as a matter of information only and it is not intended to preclude actual testing of the subject material for suitability of use and applications.

## Percent Transmittance Comparisons

Most polymeric materials permit 95% to 100% transmittance through all gauges for analyte lines less than 4 Angstroms (3.1 keV). With increasing analyte-line wavelength for a particular thin-film material, the need for a thinner gauge correspondingly increases because of higher degrees of absorption. In evaluating a thin-film substance, the entire range of analyte lines of interest and anticipated analyte concentrations in a specimen should be considered. Thin-film material and thickness should be selected that provide the greatest degree of transmittance, particularly for low concentration levels and long analyte-line wavelengths, together with other pertinent properties. In many instances, the analytes and concentration levels are not previously known and a general-purpose thin-film substance should be used.

Teflon prohibits 50% analyte-line transmittance at 3.1 keV and Kapton loses 50% of its analyte-line transmittance at 1.7 keV. Both substances are, however, very well-suited for use as thin-film sample supports because of their excellent degradation resistance, but are limited (Teflon in particular) to use with the more energetic analyte lines.

Mylar exhibits good properties with respect to degradation resistance and percent analyte-line transmittance, but it has the drawback of inherent detectable trace levels of impurities. This can be a problem if the same elements at similar concentrations are to be quantified.

A superficial examination of polycarbonate shows this substance to be acceptable for thin-film applications based on its analyte-line transmittance, which is very similar to that of 3.6  $\mu\text{m}$  gauge Mylar. However, the degradation resistance of polycarbonate makes it unsuitable for use with a broad range of chemical classifications. Its use is restricted to chemically unreactive solution specimens or powdered solid sample materials.

Polypropylene and polyethylene are similar in degradation resistance and transmittance properties. These substances are useful for the retention of many types of sample materials and can be used for thin-film sample supports encompassing the entire spectral range. A polyethylene device incorporating both a snap-on ring and thin-film sample support membrane is available from Chemplex Industries, Inc. (Figure 5). This device eliminates the need for separate attachment of a thin-film sample support material with a snap-on ring.

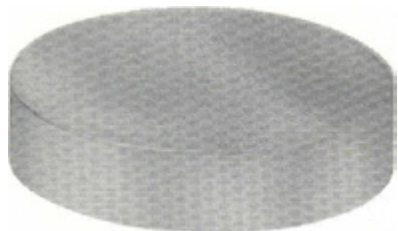

**Figure 5** SpectroMembrane® thin-film integrally formed with snap-on ring.

Polyvinylidene chloride (PVC) exhibits a sharp discontinuity in the percent transmittance correlation to analyte-line appearing at 2.8 keV; this represents the K-absorption edge for chlorine. This discontinuity and the substance's unacceptable degradation resistance, make PVC unsuitable for use in XRF sample retention.

Polystyrene exhibits poor degradation resistance, and is thus not suited for use in XRF sample retention. Other materials similarly tested and found to be unacceptable included celluloses, collodian, and nylon. Polyvinyl fluoride is currently being evaluated as a possible material for sample containment.

### Gauge Thickness

Uniformity in thin-film thickness is important with respect to minimizing variations in analyte-line transmittance. The process of manufacturing involves gauge control to within approximately  $\pm 10\%$  of nominal thickness. To evaluate the effect of variations in thickness on analyte-line absorption, percent transmittance deviations from a variety of gauges of the same thin-film substance were calculated for a number of analyte lines. Mylar was used since most of the test data were already available.

Results indicated a correlation between percent transmittance deviation units ( $\pm \%TDU$ ) to decreasing thin-film gauge and increasing analyte-line wavelength. This condition would be most pronounced with very thin-gauge substances and long analyte-line wavelength investigations. For example, a deviation of  $\pm 3\%$  TDU was determined for 2.5  $\mu\text{m}$  gauge Mylar at an arbitrarily selected analyte line of 12.4 Angstroms. Translation of  $36.79 \pm 3\%$  transmittance to analyte concentration is insignificant for analytical concern.

### Summary

Several parameters pertaining to the suitability of thin-film substances for retaining samples for WDXRF and EDXRF spectrochemical analysis have been described. The materials investigated were all synthetic polymers of various thicknesses, exhibiting differing degradation resistance and analyte-line transmittance. A comparison of percent analyte-line transmittances for thin-film substances and gauges were presented, intended to facilitate selection of a suitable thin-film substance and gauge.

Note 1: Mylar® is a registered trademark of E.I. DuPont de Nemours Co., Inc.  
Prolene®, Etnom®, SpectroMembrane® and Chemplex® are registered trademarks of Chemplex Industries, Inc.

Note 2: Table 1, Degradation Resistance of Thin-Film Substances, is replaced with the most current version.

Note 3: Figure 5. SpectroMembrane thin-film integrally formed with snap-on ring has been replaced with an alternate product of different design and configuration

### References

1 SOLAZZI, M.J., "Disposable XRF Sample Cups and Thin-film Sample Supports for X-Ray Fluorescence Analysis," Am. Lab. 16 (11), 72- 78 (1984).

Dr. Monte J. Solazzi is President, Chemplex Industries, Inc., 2820 SW 42<sup>nd</sup> Avenue, Palm City, Fl. 34990, USA. Tel: (772) 283-2700.

Reprinted from **American Laboratory**, Oct., 1983

By Dr. Monte J. Solazzi

## AN INVESTIGATION OF THE PERFORMANCE OF COMMINUTION VIALS AND BALL PESTLE IMPACT GRINDERS



IN THE PAST, powdered sample materials were comminuted in any available vials by the ball pestle impact grinding technique. The choice of vials used was limited to the familiar flat interior ended medicine-type vials with a selection of screw or snap closures. These grinding containers were not designed or necessarily suitable for providing the reproducible particle size reduction required for high degrees of spectrochemical analytical accuracies. The lack of availability of any other type of comminution vessel and insufficient understanding of the actual events occurring during the comminution process with ball pestle impact grinders, contributed to the popularity of flat interior-ended vials. This paper will discuss particle size reduction of various types of sample materials using SpectroVial® (Chemplex® Industries, Inc.) grinding vials.

Centrifugally accelerated ball pestle and sample are forced through a figure-eight path of travel.

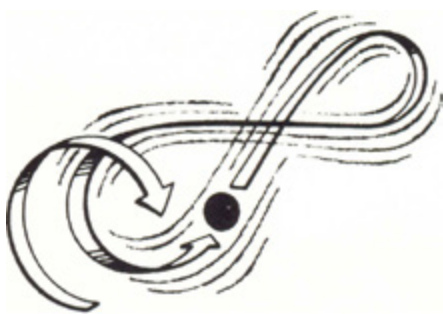

### Background

#### Chemplex SpectroMill® Ball Pestle Impact Grinder

A ball pestle impact grinder is an electromechanical device designed to rapidly and energetically propel a ball pestle contained in a cylindrical vessel with a powdered sample from one end to the other. The principle of operation of a ball pestle impact grinder is based on the unique behavior of a ball pestle and its effect on a sample. The SpectroMill® ball pestle impact grinder (Figure 1) motivates a ball pestle and sample through a longitudinal figure-eight path of travel that simultaneously rotates in a 360° pattern from one end of the grinding vessel to the other (Figure 2). However, as the ball pestle approaches one end of the grinding vessel, the grinder abruptly reverses direction opposed to the travel path of the ball pestle and sample, which increases the intensity of impact. The sample is crushed against the interior ends of the vial by the ball pestle. The cycle is repeated until a predetermined time for attaining a desired particle size has elapsed.



The degree of particle size reduction is related to comminution time, volumetric capacity of the grinding vessel, sample quantity, and type of powdered sample. To control comminution time precisely, the SpectroMill incorporates a 60-min interval timer programmable in increments of 1 min. For repetitive sample preparations, the electronic timer is set to a pre-calculated time. Re-establishing the same comminution time for subsequent sample processing is performed by depressing a reset button located within the timer dial. The unit automatically activates for the previously set time duration. A separate button switch controls manual operation, which overrides the automatic programmable timer.

SpectroMill-II Simultaneously Processes Two Similar or Dissimilar Samples

## Flat Interior-Ended Grinding Vials

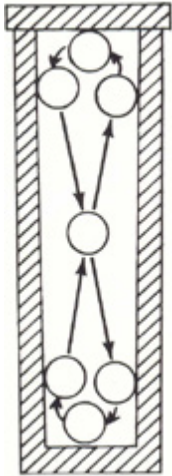

Figure 3. **Traditional flat interior-ended vial with snap cap.**

The flat interior-ended conventional grinding vials form nearly perpendicular angles with the interior walls (Figure 3). The spherical ball pestle cannot crush any sample particles that collect and cohere in these pockets on both ends of the vial. Similarly, the parting line established at the point of conjunction between the vial body and cap presents another area in which sample particles accumulate and avoid comminution. The parting line is usually at the edge of the open side of the vial immediately adjacent to the impact site. Under the thrust of the rapidly moving ball pestle, sample particles are forced and compacted into the crevice formed by the parting line and protected from ball pestle impact. Complicating this issue further, when a disposable plastic grinding vessel is used the closure is generally a completely different and less rigid type of plastic; the vial body is usually rigid polystyrene and the closure is a more pliable polyethylene plastic. The more pliable polyethylene plastic closure becomes momentarily distorted upon impact by the ball pestle and increases the gap of the parting line, and sample particles thus become entrapped and evade the comminution process.

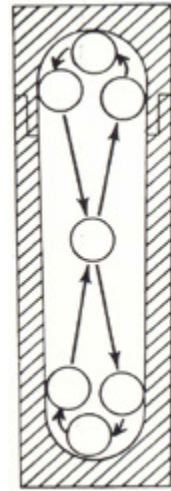

Figure 4. SpectroVials with concaved interior ends in both the vial bodies and closures.

### SpectroVial® Comminution Vials

The SpectroVial comminution vial was researched, engineered, and manufactured to serve one specific function: to reduce the sample preparation error for processing powdered samples in ball pestle impact grinders. The vials are cylindrical vessels with concaved interior ends in both the vial bodies and closures (Figure 4). The concaved interior ends form infinite sites to allow impacting and milling to occur, eliminate areas in which sample particles may become entrapped and avoid comminution, and promote intimate particle intermixing since the sample is continuously encouraged to rotate by the figure-eight travel path of the ball pestle. Additionally, the parting line between the vial body and closure is a considerable distance away from the ball pestle impact site to avert the accumulation and compaction of sample particles. Close manufacturing tolerances also limit the gap of the parting line to further reduce the likelihood of sample particle accumulation. In a given cycle, as the ball pestle departs from its arc of travel guided by the radial end of the vial, its rate of speed is centrifugally accelerated. Concurrently, the mechanics of the SpectroMill grinder develops a reversal of direction and imposes a sudden thrust on the ball pestle and sample to further accentuate their speed for impact and milling on the opposite end of the vial. This process continues until the sample is satisfactorily reduced in particle size.

SpectroVials (Figure 5) are manufactured in rigid clear polystyrene plastic with polystyrene friction fitting snap-on caps, and in stainless steel with screw caps fabricated of the same metal for both open ends of the vial body (Figure 6) to facilitate and ensure thorough cleansing. The polystyrene vials are disposable and the stainless steel units are, of course, reusable. Currently under investigation for use as a vial is heat-treated titanium-carbide, which is similar to tungsten carbide in hardness but not brittle and not as expensive to manufacture.

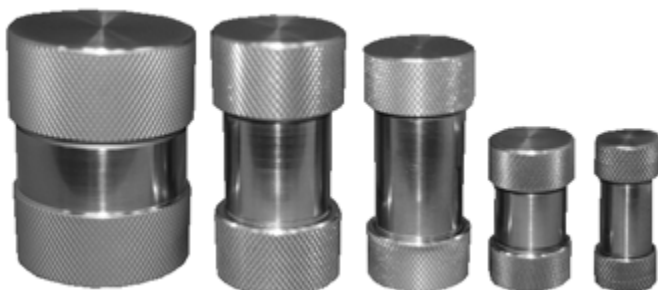

Figure 6  
**Metal SpectroVials**



Figure 5  
**Disposable polystyrene SpectroVials**

## Experimental Statistical Analysis

The performance of SpectroVials and flat interior-ended vials was examined by comminuting sand, silicon dioxide, in a SpectroMill programmed for a fixed time duration. The ground sample material for each test aliquot was collimated through a 44 µm screen, collected, weighed, and expressed as a percentage of sample quantity equal to or less than 44 µm in particle size.

Table 1

**Statistical analysis\***

Spectro Vials			Flat interior-ended vials		
Wt% collected	$(x_i - \bar{x})$	$(x_i - \bar{x})^2$	Wt% collected	$(x_i - \bar{x})^2$	$(x_i - \bar{x})^2$
19.9	0.0	0.00	17.7	+0.1	0.01
19.6	+0.3	0.09	17.9	+0.3	0.09
19.5	+0.4	0.16	19.8	+2.2	4.84
20.0	+0.1	0.01	16.4	-1.2	1.44
19.8	-0.1	0.01	16.4	-1.2	1.44
19.8	-0.1	0.01	17.0	-0.6	0.36
19.8	-0.1	0.01	16.9	-0.7	0.49
20.4	+0.5	0.25	20.5	+2.9	8.41
19.9	0.0	0.00	17.3	-0.3	0.09
20.0	+0.1	0.01	16.3	-1.3	1.69
$\Sigma = 198.7$		$\Sigma = 0.55$	$\Sigma = 176.2$		$\Sigma = 18.86$
	$\bar{x} = 19.9 \text{ wt\%}$			$\bar{x} = 17.6 \text{ wt\%}$	

\*Sample material: silicon dioxide.  
Sample aliquot: 5 g/test.  
Weight percent collected after collimation through a 44-µm screen.

Sand was selected as the experimental material for this application for several reasons: relative hardness and resistance to particle size reduction particularly in polystyrene vessels; initial coarse particle size of 149 µm with only 5 wt% passing through a 44 µm screen; and abundance of sample material for similar comparisons. Disposable polystyrene SpectroVials with a volumetric capacity of 30 ml and comparable flat interior-ended vials and two methyl methacrylate 11 mm diameter ball pestles were used for each test sample. The SpectroMill was programmed for automatic operation with a comminution time of 25 min for processing each test aliquot. After each completed grinding cycle, the comminuted samples were weighed and sieved. The collected amounts were again weighed and expressed as percentages of material passing through a 44µm screen. Ten replicate 5-g sand samples were processed in polystyrene SpectroVials and a duplicate test series was similarly prepared in polystyrene flat interior-ended polystyrene vials. A statistical analysis was performed to determine the variations in processing both groups of samples. The data are tabulated in Table 1, and Eqs. (1) and (2) were used to calculate the standard deviation,  $\sigma$ , and coefficient of variation,  $v$ , for each test group. Table 2 shows the calculated variations for the SpectroVial and flat interior-ended vials.

$$\sigma = \sqrt{\sum_{i=1}^n (x_i - \bar{x})^2 / (n - 1)} \quad (1)$$

where  $\sigma$  = standard deviation

$X_i$  = the  $i$ th individual value

$n$  = number of observed values

$\bar{x}$  = arithmetic mean.

Examination of the data demonstrates the excellent performance and reliability of SpectroVials in statistically reproducing the weight percent quantity of test material collimated through a 44-µm screen, 19.9% ± 0.25, and the poor performance of flat interior-ended vials, 17.6% ± 1.5.

## Comparison Study

The experiment with silicon dioxide was extended to include evaluation of the effects on particle size by varying processing time, grinding media, and sample quantity. This investigation used two stainless steel SpectroVials® of different volumetric capacities and disposable polystyrene SpectroVials. The parameters tested for each group were varied.

The first test group used a 90-ml stainless steel SpectroVial, 66 mm long x 54 mm in diameter, and contained a 15-g sample for each test. Because of the sample quantity employed, two stainless steel ball pestles of 12.7-mm diameter were used. The first sample was processed for 10 min and subsequent samples were ground in increasing 10-min increments. The wt% of ground silicon dioxide passing through a 44 µm screen was calculated (Table 3) and plotted against processing time (Figure 7). The data show excellent correlation and illustrate that within a 30-min cycle, 95.9 wt% of silicon dioxide is equal to or less than 44 µm in particle size.

Table 3

### Sieve analysis of silicon dioxide\*

Comminution time, min	Wt% passing through a 44-µm screen
Nil; unprocessed	5.0
10	65.0
20	87.2
30	95.9

\*Sample aliquot: 15 g/test.

Grinding media: large stainless steel SpectroVial with two stainless steel ball pestles.

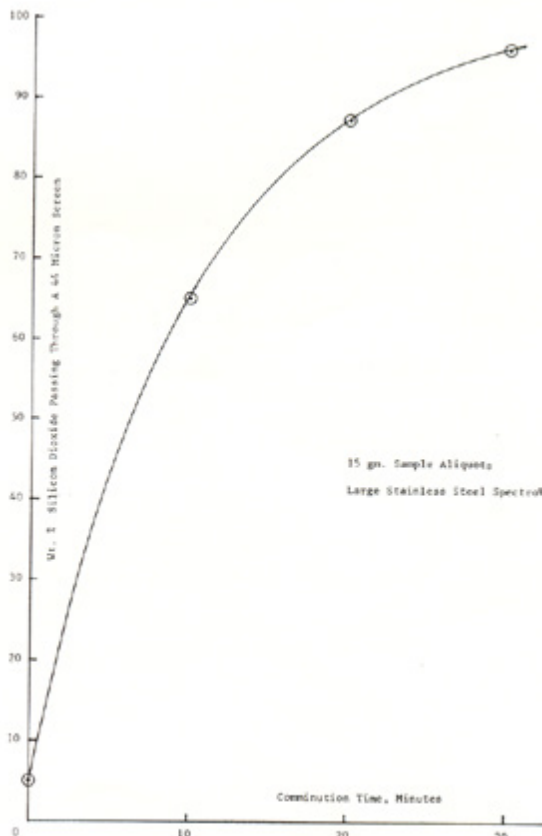

Figures 7-9 Comminution analyses of wt% of ground silicon dioxide passing through a 44-µm screen plotted against processing time.

The second test group consisted of 5-g aliquots comminuted in a 35-ml stainless steel SpectroVial, 76 mm long x 33 mm in diameter, containing one 11-mm-diameter stainless steel ball pestle. It was also determined that a 5-g sample aliquot was adequate to present for spectrochemical analysis. The small size SpectroVial was commensurate with the smaller quantity of sample material processed. This group of samples was processed in increments of 5 min up to 15 min and collimated. Within a 15-min processing time, 96.2 wt% passed through a 44 µm screen. The data for this study also display excellent correlation, as tabulated in Table 4 and illustrated in Figure 8.

The last test group in this series also involved 5-g silicon dioxide sample aliquots. For this application, however, disposable polystyrene SpectroVials, 75 mm long x 33 mm in diameter, and two 11-mm diameter methyl methacrylate ball pestles were used as the grinding media. Varied processing times were selected for individual tests up to 45 min and the wt% passing through a 44µm screen was calculated (Table 5). The weight percent of comminuted sand passing through the screen representative of the arithmetic mean, X, of 19.9 wt% was taken from the statistical analysis section (Table 1) to evaluate its position in the drawn curve relative to the other points. Figure 9 demonstrates excellent correlation, including the point inserted from Table 1 (19.9 wt%).

## Other Material Investigations

The Applications Laboratory at Chemplex Industries, Inc. is frequently presented with a variety of sample materials submitted from different sources for evaluation. The following section briefly describes several experiments of various types on different materials that were difficult to process. In each example, SpectroVials were used.

Table 4

### Sieve analysis of silicon dioxide\*

Comminution time, min	Wt% passing through a 44- $\mu$ m screen
Nil; unprocessed	5.0
5	60.8
10	86.2
15	96.2

\*Sample aliquot: 5 g/test.  
Grinding media: medium size stainless steel SpectroVials with one stainless steel ball pestle.

Table 5

### Sieve analysis of silicon dioxide\*

Comminution time, min	Wt% passing through a 44- $\mu$ m screen
Nil; unprocessed	5.0
25 <sup>a</sup>	19.9 <sup>a</sup>
35	25.0
45	30.0

\*Sample aliquot: 5 g/test.  
Grinding media: large polystyrene SpectroVial with two methyl methacrylate ball pestles.

<sup>a</sup>These data were taken from the statistical analysis section, Table 1.

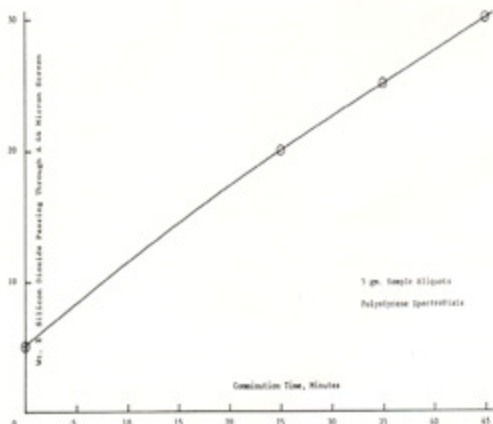

Figure 9

Figure 8

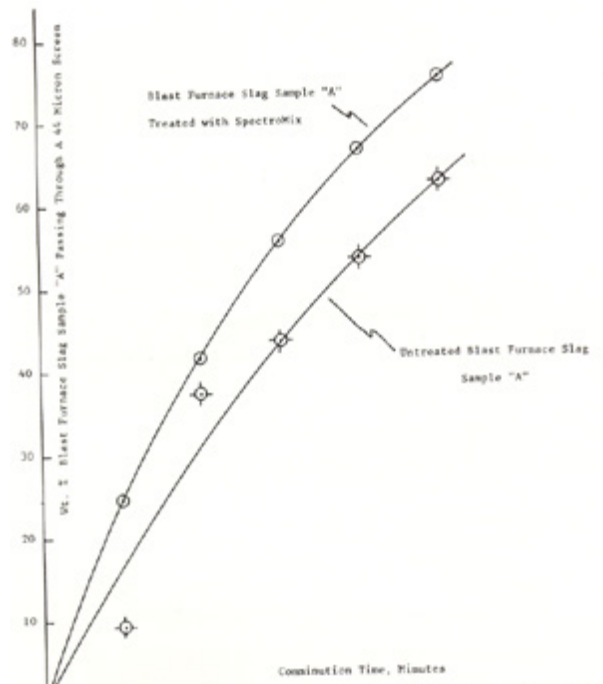
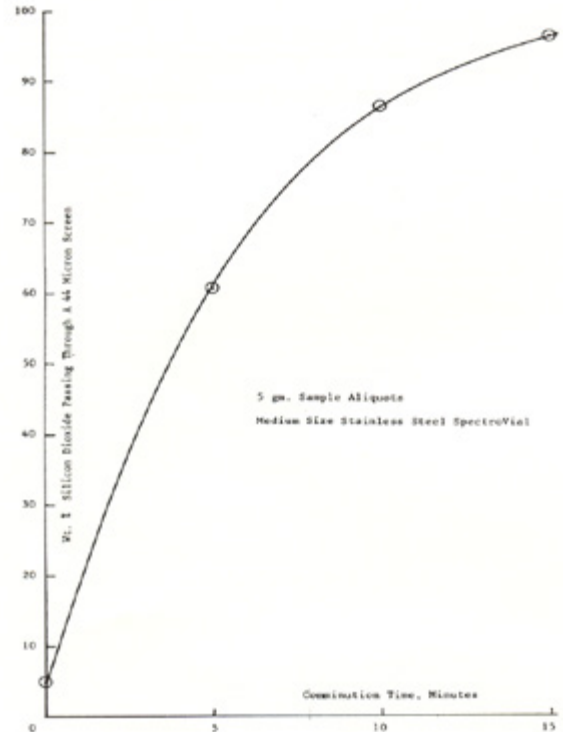

Figure 10 Comminution analysis of slag sample A.

## Blast Furnace Slags

Three blast furnace slag samples were submitted for a suggested sample preparation procedure. A typical analysis of the major constituents was disclosed as follows: 24% SiO<sub>2</sub>, 39% CaO, 7% Fe<sub>2</sub>O<sub>3</sub>, 10% MgO, 10% MnO, and 7% Al<sub>2</sub>O<sub>3</sub>. The samples were received in chunks of approximately 0.5 x 0.5 x 2 cm. Two of the slag samples, which will be identified as A and B, were occluded with steel balls ranging in size up to approximately 2 mm in diameter. The third sample, C, was relatively free of foreign metallic occlusions. By weight, samples A and B contained approximately 96% and 2% steel balls, respectively; none were detected in sample C.

The difficulty in processing these three samples was related to the unwanted presence of the occluded metallic balls. In the form received, the blast furnace slag samples were unsuitable for standard comminution procedures. The chunks were first de-agglomerated with a mallet and the steel balls were removed using a magnet. The average chip size was approximately 2 x 2 x 3 mm. To ensure complete occluded steel ball removal, each sample was subjected to a 2-min process in the SpectroMill using a stainless steel SpectroVial. The extraneous steel balls were again magnetically removed.

A 15-g aliquot of sample A, which contained the greatest quantity of occluded steel balls, was comminuted in a 66-mm long x 54-mm diameter stainless steel SpectroVial with two 12.7-mm diameter ball pestles in increments of 5 min. up to 25 min. After each grinding cycle a 1-g aliquot was removed for sieving through a 44 μm screen and the quantity collimated was weighed and expressed as a weight percent.

Both factions of the removed 1-g aliquot were returned to the vial for further comminution. *Table 6* shows the data for this sample preparation procedure and *Figure 10* provides a graphic illustration. Inspection of the data shows an unsatisfactory distribution of points surrounding the best-drawn curve. It was suspected that the sample particles during the comminution process were not adequately intermixing for ball pestle impact. The experiment was then repeated, but this time a 0.5-g SpectroMix™ grinding/briquetting aid was added to the 15-g sample in pre-measured capsule form.

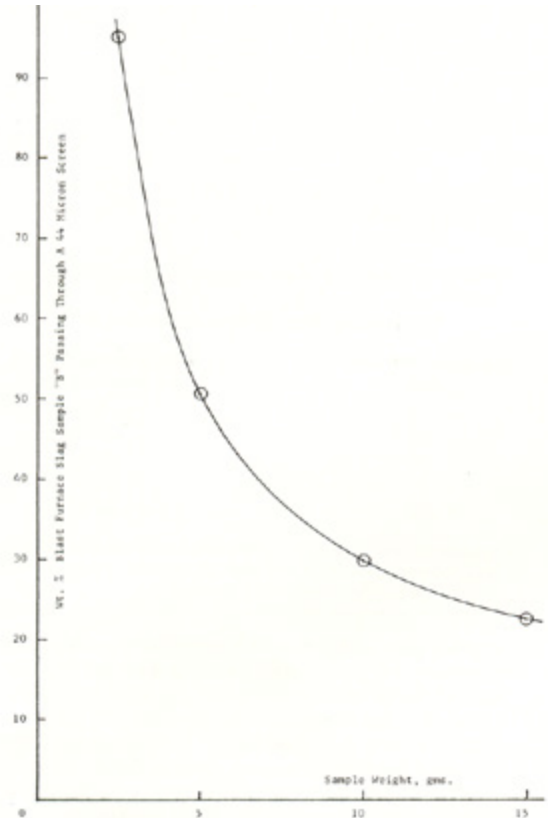

Figure 11 Comminution analysis of slag sample B.

Table 6

### Sieve analysis of blast furnace slag A\*

Comminution time, min	Wt% passing through a 44-μm screen
5	9.1
10	37.1
15	43.4
20	53.2
25	62.5

\*Sample aliquot: 15 g with 1 g removed for sieving after each 5-min interval; collimated and residual factions combined with original aliquot for subsequent processing.

Table 7

### Sieve analysis of blast furnace slag A processed with SpectroMix\*

Comminution time, min	Wt% passing through a 44-μm screen
5	24.8
10	41.4
15	55.6
20	66.5
25	75.0

\*Sample aliquot: 15 g; same as in Table 6. Sample-to-SpectroMix ratio = 30 : 1.

Table 8 Comparison between untreated and SpectroMix processed blast furnace slag A

	wt% passing through a 44- $\mu$ m screen				
	5 min	10 min	15 min	20 min	25 min
SpectroMix processed slag	24.8 <sup>a</sup>	41.4 <sup>a</sup>	55.6 <sup>a</sup>	66.5 <sup>a</sup>	75.0 <sup>a</sup>
Untreated slag	9.1 <sup>b</sup>	37.1 <sup>b</sup>	43.4 <sup>b</sup>	53.2 <sup>b</sup>	62.5 <sup>b</sup>
% Increase using SpectroMix	172.5%	11.6%	28.1%	25.0%	20.0%

<sup>a</sup>These data were taken from the sieve analysis in Table 7.

<sup>b</sup>These data were taken from the sieve analysis in Table 6.

Examination of the data in *Table 7* shows a significant improvement in results and excellent graphic correlation (*Figure 10*). Both of the curves were plotted in the same graph to provide a better view of the improvement relative to the untreated sample. To further illustrate the improvement in particle size reduction realized with SpectroMix, a comparison between untreated and SpectroMix processed blast furnace slag sample A was performed (*Table 8*). The data were taken directly from *Tables 6 and 7*, and the percentage increase of collimated material in relation to each period of processing was calculated. The use of the grinding aid also facilitated cleansing operations because of its lubricious nature and reduced the procedure to a simple dry paper towel wipe.

Table 9 Sieve analysis of blast furnace slag B\*

Sample quantity, g	Wt% passing through a 44- $\mu$ m screen
2.5	95.0
5.0	50.6
10.0	29.8
15.0	22.5

\*Comminution time: fixed, 5 min per test.  
Grinding additive: SpectroMix, 3.3 wt%.

Table 10 Sieve analysis of blast furnace slag C\*

Comminution time, min	Wt% passing through a 44- $\mu$ m screen
10	56.6
20	82.0
30	94.2
35	97.6

\*Sample aliquot: 10 g per test.  
Grinding additive: SpectroMix, 3.3 wt%.

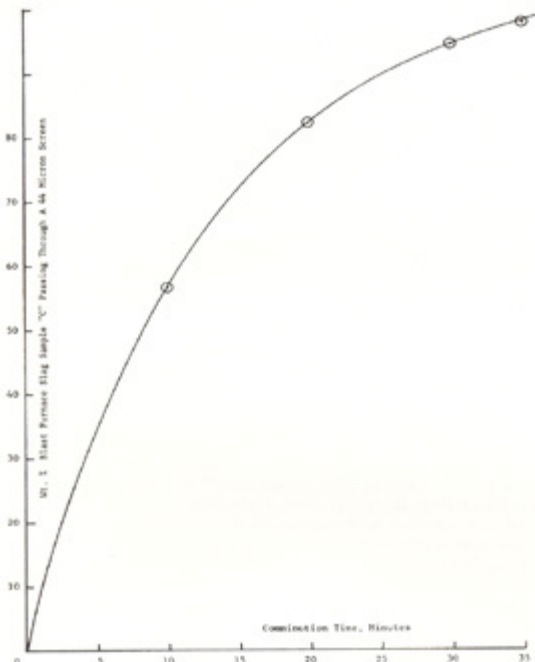

Figure 12 Comminution analysis of slag sample C.

Sample B was used to illustrate the effect sample quantity had on particle size. The SpectroMill was programmed for a 5-min comminution cycle per test. The same stainless steel SpectroVial was again used. SpectroMix powder was added to each sample aliquot in a proportion of 3.3 wt%. Four test samples of 2.5, 5, 10, and 15 g were prepared. *Table 9* shows the reduction in the weight percents of collimated materials with increasing sample quantity. *Figure 11* displays excellent correlation of the plotted points and demonstrates the effect of sample quantity on particle size.

The last blast furnace slag, sample C, was similarly processed with 3.3 wt% SpectroMix and was used to determine the length of comminution time required to yield at least 95 wt% of collimated material passing through a 44- $\mu$ m screen. The same stainless steel vial and ball pestles were used to keep variables to a minimum. Each sample aliquot tested was 10 g. The data presented in *Table 10* show that approximately 30 min was sufficient to grind the sample to a particle size in which 95 wt% passed through the 44  $\mu$ m screen. *Figure 12* displays the excellent correlation between each of the plotted points.

### Tin Ores

The study of tin ores was particularly interesting because the analyst had already established a viable sample preparation procedure and was exploring the possibility of incorporating the SpectroMill and SpectroVials in the scheme. Specific conditions were outlined. Fixed quantities of sample (2 g) and a grinding additive (12 g) had to be maintained. Evaluation consisted of determining the length of time required for each 14-g sample/additive mixture to furnish a particle size in which at least 95 wt% passed through a 44- $\mu$ m screen. Seven tin ore specimens were submitted for study. A 66-mm long x 54-mm-diameter stainless steel SpectroVial with two 12.7-mm-diameter stainless steel ball pestles were employed as the grinding media. Each tin ore specimen was processed in the ball pestle impact grinder, sieved, and the collected quantity expressed as weight percent. *Table 11* shows the results of this study; a processing time of 35 min was adequate to comminute the tin ores to the desired particle size.

### Firebrick

A single firebrick was submitted for comminution analysis. The only requirement was not to exceed a processing time of 5 min to achieve a particle size of equal to or less than 44  $\mu$ m. A 76-mm-long x 33-mm-diameter stainless steel SpectroVial with two 11-mm diameter ball pestles was used as the grinding media. The sample aliquot per test was 5 g after the firebrick was pulverized. According to the data in *Table 12*, within a 5-min comminution cycle 96.3 wt% of the sample passed through a 44  $\mu$ m screen. *Figure 13* illustrates the distribution of points.

**Table 11**  
**Wt% passing through a 44- $\mu$ m screen**

Sample no.	15 min	30 min	35 min (extrapolated)
1	68.8	93.8	99.5
2	65.3	93.8	100
3	69.0	93.1	98.3
4	70.0	93.6	98.0
5	70.1	93.2	98.0
6	63.9	90.5	97.0
7	60.3	89.2	95.5

**Table 12**  
**Sieve analysis of fire brick\***

Comminution time, min	Wt% passing through a 44- $\mu$ m screen
1.0	69.9
2.5	89.5
5.0	96.3

\*Sample aliquot: 5 g/test.

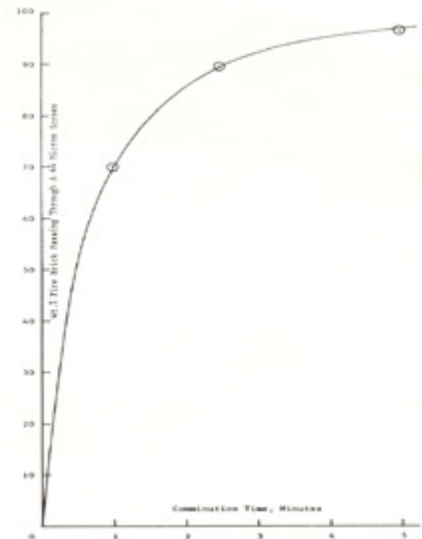

**Figure 13** Comminution analysis of fire brick.

### Summary and Conclusion

The effectiveness of SpectroVials in comminuting samples in a ball pestle impact grinder in preparation for spectrochemical analysis has been demonstrated. The data presented in *Table 1* and *Table 2* illustrates the higher degrees of precision and increased particle size reduction obtained with SpectroVials. The improvement in reproducibility is attributed to the concaved interior ends in both sides of the vial, the smooth unobstructed interior walls, and the displacement of the point of conjunction between the vial body and closure from the impact site. During comminution, individual sample particles are unable to elude ball pestle impact by virtue of the interior radial ends and the absence of pockets or crevices for sample material to collect. The resultant comminuted sample is homogeneously blended and uniformly reduced in particle size and distribution with a savings in processing time.

SpectroVials are available in different volumetric capacities in both polystyrene plastic and stainless steel to permit a comprehensive range of sample material processing. The future use of heat-treated titanium-carbide materials may extend the range of sample material processing and reduce comminution time while avoiding the brittle nature and high manufacturing costs of tungsten carbide. With the use of the SpectroMill, the analyst can precisely control particle size reduction by varying cycle time and sample charge.

The investigations described in this paper illustrate the success of SpectroVials in reducing sample preparation error. The range of sample materials that can be processed with SpectroVials is extensive, and the examples cited demonstrate typical superior performance in the comminution process.

**Note:** SpectroMill®, SpectroVial®, SpectroMix® and Chemplex® are registered trademarks of Chemplex Industries, Inc.  
Dr. Monte J. Solazzi is President, Chemplex Industries, Inc., 2820 SW 42<sup>nd</sup> Avenue, Palm City, Fl. 34990, USA. Tel: (772) 283-2700.

By Dr. Monte J. Solazzi

## Comminution Device for X-Ray Spectrochemical Analysis

**S**AMPLE SUBSTANCES ranging from single to multiple-compound structures, classified as compositionally complex in this article, comprise combinations of different particles. Each is characterized by its separate chemical and physical properties, e.g., chemical composition, particle size, shape, hardness, and density. In practice, this is a fair representation of the samples generally presented to the analyst for direct X-ray spectrochemical analysis, and as such, they are not acceptable. Any differences or variation in the constituent sample particles with respect to chemical and physical properties are potential factors affecting the X-ray data and degree of analytical accuracy. Comminution reduces these discrepancies to minimal levels.

The objective of the comminution procedure is to reduce the constituent particles to a uniform size, shape, distribution, and level of insignificant influence on analytical data in a statistically reproducible manner. The comminution equipment must be capable of utilizing a single set of operating conditions common in meeting this objective, regardless of initial differences in sample composition complexities and physical characteristics. This imparts a high degree of credibility to the sample preparation procedure with the foreknowledge that each type of sample substance is effectively comminuted. The comminution equipment must also be relatively fast and simple to operate, maintain pace with current and future laboratory needs, and be ergonomically designed to minimize operator discomfort, especially for routine sample processing. The comminution equipment must also provide a means to minimize the introduction of transition wear-element contamination to the sample substance and wear to the grinding vessel and media. The GyralGrinder® (Chemplex® Industries, Inc.), a comminution device featuring variable frequency and intensity of impact control, meets these requirements.

### Principle of Operation



Figure 1  
Comminution Vessel

The GyralGrinder is an electromechanical device that imparts an eccentric gyral motion to a comminution vessel containing a sample substance and freely mobile grinding media (Figure 1). The eccentric gyral motion is created by inertia of the mechanics of the system to generate a controlled imbalance condition resulting in an energetic motivation of the grinding vessel. Comminution is effected by collision and milling actions by the grinding media on the sample substance.

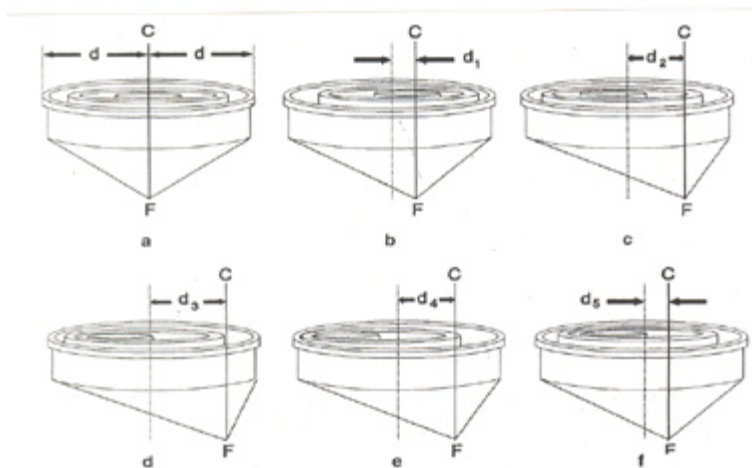

Figure 2 Typical gyral motion of comminution vessel.

Figure 2 illustrates a grinding vessel located a distance ( $d$ ) from a focal point ( $F$ ) relative to the center axis of the system ( $C$ ). At rest (Figure 2a), the comminution vessel together with its grinding media and sample are stationary (the grinding media are shown to be in center alignment with the center axis of the system for illustrative purposes). As a moment is initiated by the mechanics of the system pivoting at the focal point  $F$ , Figure 2b, the grinding vessel is laterally displaced a distance ( $d_1$ ) from the center vertical axis ( $C$ ); the grinding media and sample generally lag behind the grinding vessel displacement direction as they are propelled by its trailing side. Subsequent increases in instability, Figure 2c, gyrally enlarge the displacement distance ( $d_2$ ) of the grinding vessel relative to the center vertical axis up to a physical limitation imposed by other mechanics integrated in the system. At the limitation displacement distance ( $d_3$ ), Figure 2d, of the grinding vessel, the mechanics gyrally reverse displacement direction accompanied by a corresponding decrease in displacement distance ( $d_4$ ), Figure 2e, in a circular arc configuration (not shown). The grinding elements, however, continue in the same initial travel path with increased speed and inertia propelled by the trailing side of the grinding vessel to impact its interior walls. The reversal of grinding vessel direction in the oncoming path of the sample substance and grinding media is extremely energetic and is primarily responsible for comminution. The cycle repeats itself in the opposite direction, Figure 2f. Furthermore, the reversal of displacement direction of the grinding vessel in a circular arc adds a milling effect to the sample substance created by the grinding media that acquires a spin attributed to the gyral mechanics.

The mechanics of operation are portrayed in slow motion to illustrate the principles involved in this equipment. In practice, the comminution process is extremely rapid and highly energetic. Additionally, by the introduction of control on the number of displacement distance occurrences within an interval of time, the frequency and intensity of impacts become variable. This feature provides the analyst with the capability of adjusting the comminution process to range from a simple gentle grind to a most vigorous and energetic action.

Most importantly, independent operator control of intensity and frequency of impact, together with other features incorporated in the device reduce the comminution process to the use of a common set of operating parameters applicable to all sample substances regardless of their dissimilarities in composition complexity and physical characterization. Control over the frequency and intensity of impact level ensures that transition wear-element contamination to the sample is significantly minimized; in addition to reduced wear to the comminution vessel and grinding elements.

## Experimentation

A series of experiments were conducted relating to particle size weight fractions collected from comminuted sample material processing. Four different arbitrary sample substances were selected principally for their relative dissimilarities in composition complexity and physical characterization.

The GyrulGrinder can be operated in several different modes: intensity of impact held constant and processing time varied, processing time held constant and intensity of impact varied, and both processing time and intensity of impact varied. A typical representation of the comminution process and experiments to be performed in this report is shown in *Figure 3*. This relates the particle size weight fraction of the sample collected corresponding to either processing time, intensity of impact, or both. The degree of curvature appearing at the upper end of the curve represents the range at which no further particle size reduction is realized with additional processing for a specific sample material substance, comminution vessel material, and equipment.

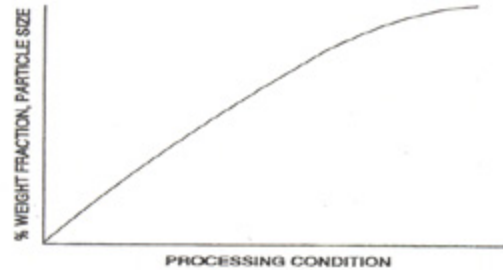

**Figure 3** Particle size versus processing time, intensity of impact on comminution vessel substance.

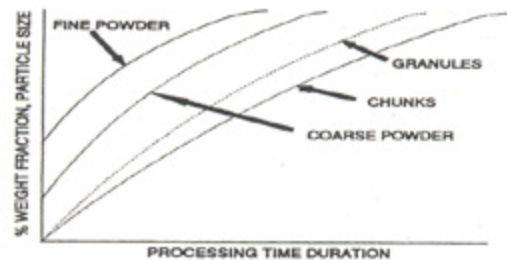

**Figure 4** Typical ineffectiveness of traditional comminution equipment.

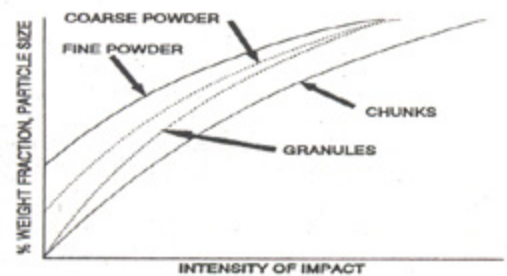

**Figure 5** Improvement in the comminution process attributed to varied intensity of impact settings.

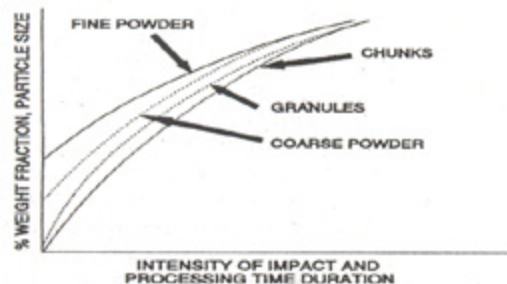

**Figure 6** Comminution effectiveness under a common set of conditions in processing sample substances of dissimilar chemical and physical characterization.

### Varied Processing Time

The device was operated without benefit of utilizing the variable intensity of impact control, which, in principle, is similar to the operational performance of traditional comminution equipment. Each sample substance was processed for specified time duration and its respective particle size weight fraction collected as previously described. The results of this test are exhibited graphically in *Figure 4*. As expected, the fine powdered substance required less processing time in producing the greatest percentage of collected comminuted particles. Sample substances initially presented in chunk physical form dictated the longest processing time in generating similar particle sizes. The notation that all curves are widely separated and do not converge is clearly reflective of the dissimilar behavior of different sample substances when subjected to the same processing conditions. Most importantly, this illustrates that the operating conditions employed for a given classification of sample substances are not presumably translatable to another without implementing operational adjustments.

### Varied Intensity of Impact

An experiment was performed that involved holding processing time fixed and varying intensity of impact, as shown in *Figure 5*. A significant improvement in the comminution process is indicated by the convergence of the individual curves to a point common to the different sample substances with the exception of the chunky sample material, which still presented difficulty as evidenced by its displacement and degree of departure from convergence with respect to the other curves. Ideally, curves generated by dissimilar sample substances should decrease in their displacement from each other and converge at some common point. A common point of convergence represents the highest degree of effectiveness in the process realized for given sample substances, comminution vessel material, and grinding equipment. It is indicative of applying a single set of operational parameters common to all sample substances within the range of analytical interest.

### Varied Processing Time and Intensity of Impact

The last experiment was reflective of the instrument's ability to process sample substances of varied compositional complexity and physical characterization. For this test, both processing time and intensity of impact were varied. A GyrulGrinder operated in this manner incorporates the benefits of both varied comminution time and intensity of impact processes into a common set of operating parameters. The results of the test are represented in *Figure 6*. The convergence of all curves at approximately the same point common to all the sample substances clearly demonstrates the comminution effectiveness of the device. The improvement in the comminution process is directly attributed to the use and application of the intensity and frequency of impact control. As illustrated, this feature provides a common set of operating conditions at which virtually any type of sample substance, regardless of dissimilarities in chemical composition and physical properties, is uniformly processed. The resultant sample substances are similar in particle size and homogeneously distributed for improved statistical precision and analytical accuracy for direct X-ray spectrochemical analysis.

### Comminution Vessels

Selection of the most appropriate comminution vessel substance is determined by material hardness, for further maximizing of the comminution process and avoidance of transition wear-element contamination to the sample. The tests in this study were performed in a hardened steel comminution vessel, which will satisfy most laboratory applications, and is supplied as a standard item with the instrument. Typical wear-element contamination from a hardened steel comminution vessel is caused by iron, chromium, silicon, manganese, and carbon. It is reasonably resistant to abrasion and very durable for moderate to high intensity and frequency of impact settings.



For applications requiring a harder grinding vessel substance and avoidance of transition wear element contamination attributed to hardened steel, different and harder vessel substances are optionally available. They include tungsten carbide, alumina ceramic, and zirconia ceramic. Generally, a harder comminution vessel material results in shorter processing times and decreased intensity of impact level settings. Empirical investigations and testing similar to those described in this presentation are generally required prior to actual sample substance processing and with each change in comminution vessel material. This procedure will assist in determining the optimum common operating parameters to accommodate the expected types or classifications of samples submitted for X-ray spectrochemical analysis. Once these common conditions are empirically determined and established, they should remain reasonably constant for all subsequent similar sample material processing.

## Instrument Features

The GyralGrinder is a freestanding unit at an average determined height intentionally selected to reduce operator bending and fatigue. The operating controls are conveniently located in the top lid cover, which is supported by dual pressurized gas springs, and lifts upward and back out of the way. This enables close access to the grinding vessel chamber in a standing position. With the lid cover in the closed position, the controls are also within easy reach, are spatially located in groups of function similarities, and are accessible in a standing position.

## Comminution Vessel Clamping Mechanism

The comminution vessel clamping mechanism employs a uniquely engineered single-handle cam-operated lever locking design that pivots out of the way. This greatly facilitates removal of the comminution vessel and further provides unobstructed access to the comminution vessel chamber in a standing position. The critical components in the clamping mechanism are fabricated from hardened chrome steel for extended longevity of use. A dust rail is also incorporated within the comminution vessel chamber that serves to collect any residual powdered sample substances, maintains the gyral mechanics relatively dust free, and facilitates cleanup of inadvertent spills.



## Controls

All operating controls are located on the exterior of the lid cover. They include a lighted push-button Main switch, a lighted pushbutton manual On/Off switch, a lighted push-button Momentary Operation switch, a control for the intensity of impact, and a programmable electronic interval timer in 1-min increments. The push-button switches are also illuminated in different color codes for further ease of identification. The Main switch supplies power to the unit. The Manual switch is employed to operate the unit without a fixed, timed processing interval. The Momentary switch engages the unit for as long as this control is held down in the "On" position. The timer is programmable for fixed time durations in processing sample substances for similar time intervals in 1-min increments. The device utilizes solid-state electronics and controls, which are also located in the lid cover.



## Miscellaneous Features

The instrument is constructed of heavy gauge steel and is electro statically coated with a durable finish. It incorporates sound-absorbing material to reduce noise generation to acceptable limits, casters for intermediate mobility to the installation site, and skid-resistant leveling legs to account for irregularities in flooring. Safety switches and lid cover locking devices are also incorporated.

## Conclusion

By the introduction of operator-controllable variable intensity and frequency of impact to powdered sample material comminution, innumerable types of sample substances of varying chemical compositionally complexity and physical characterization are effectively and similarly comminuted by the utilization of a single common set of operating parameters. Transition wear-element contamination to the sample substance and wear to the comminution vessel and components are significantly minimized by controlling displacement distances and frequency of impact occurrences, within an interval of time and associated intensities. Other features incorporated in the instrument are intended to greatly facilitate the comminution process concurrent with providing ease of operation for the analyst.

GyralGrinder® and Chemplex® are registered trademarks of Chemplex Industries, Inc.

*Dr. Monte J. Solazzi is President, Chemplex® Industries, Inc. 2820 SW 42<sup>nd</sup> Avenue, Palm City, FL 34990, USA. Tel: (772) 283-2700. The author thanks Mr. Hector Castaneda for his interest in this project and his time and effort in processing the various sample substances and collection of data.*



[CLICK HERE TO RETURN TO FRONT PAGE](#)

=====

**PLACING ORDERS**

=====

**Acceptance of Terms and Conditions.** By placing an order the purchaser agrees to acknowledge to have read the terms and conditions herein and accepts them without recourse. Prices are subject to change without advance notification. Chemplex reserves the right to effect engineering changes, product deletions and other changes without advance notification. Any inadvertent errors are not the responsibility of Chemplex Industries, Inc.

**On-Line Orders.** Orders and comments may be submitted On-Line. Refer to our website at:

<http://www.chemplex.com>

**Telephone Orders.** Telephone Orders may be placed between 8:30 AM and 5:00 PM EST. Orders placed before 3:00 PM (1500 hours) are usually processed for shipment the same day. Written, clearly marked "Confirmations" are suggested on verbal orders to avoid duplications. Any discrepancies between verbal and written orders are assumed by the customers. Please be specific with details to avoid unnecessary delays.

**Toll Free Number: 1-800-4-CHEMPLEX (800-424-3675) or (772) 283-2700**

**Written Orders.** Submit written orders to our mailing address (below) or to our fax number. Orders are accepted and processed subject to current prices.

**Fax Orders.** Submit Fax orders to:

**(772) 283-2774**

**Credit Card Orders.** We accept **Visa, MasterCard and American Express**. For your protection, please **do not provide your credit card information via e-mail**. For security you should only provide us with your credit card information by telephone, fax or mail.

**BLANKET ORDERS.** For customers routinely purchasing specific products, a blanket order may be established. This provides for the automatic shipment of the item(s) on a regular basis, greatly benefits the consumer by pricing at the higher volume discount level, eliminates issuance of additional purchase orders and assures uninterrupted customer operation by prompt deliveries. Contact us for additional details.

**MINIMUM ORDER**

USA  
All other countries

\$50 Minimum Order  
\$75 Minimum Order

**MAILING ADDRESS**

**Chemplex Industries, Inc.  
2820 SW 42nd Avenue  
Palm City, FL 34990-5573  
USA**



[CLICK HERE TO RETURN TO FRONT PAGE](#)

=====

## SHIPPING TERMS

=====

Shipping Point Palm City, FL 34990-5573 USA  
FOB Point Palm City, FL 34990-5573 USA  
Shipping Prepaid and separately added to invoice  
Charges except by truck and air freight that are shipped Collect. Foreign orders are shipped Ex-Factory.

**Insurance.** Available by carrier at current rates and by specific request only when placing orders. Insurance costs are to the "Buyer's Account".

**Special Packing.** Many types of merchandise require special packaging to comply with government rules and regulations and to ensure receipt of undamaged equipment. Any extra packing charges are included in the Handling charge listed in the invoice.

**Title and Ownership.** Title and ownership of all merchandise is transferred to consignee upon delivery to a commercial carrier. Acknowledgment of receipt in good condition of the merchandise is made by commercial carrier.

=====

## PAYMENT TERMS

=====

**Established Accounts:** Net 30 days from date of invoice to firms in good credit standing.

**Non-Established Accounts.** You may apply for a new account, with or without a new order, by simply completing our Online Credit Application Form , or you may prefer to fax or mail it to us. Allow up to 3 weeks for processing. In the interim, payment against orders may be made by any of the following: credit card, C.O.D., electronic wire transfer, certified check and payment in advance. If credit references are not furnished, the above payment terms remain in effect.

**Delinquent Accounts.** Invoices not paid within 30 days are subject to a 1.5% Finance Charge in addition to a one-time \$10.00 US Accounting fee. Delinquent accounts will be submitted to a collection agency after our standard "net 30 days" terms have elapsed.

=====

## CANCELLATIONS

=====

Cancellations of orders are accepted only on unshipped stock items and upon appropriate notification and confirmed in writing. Custom manufactured products are not subject to cancellation.

=====

## MERCHANDISE RETURN AND/OR EXCHANGE

=====

No items are accepted for return or exchange without advance notification and our issuance of a Return Authorization Number (RAN). No items are considered for return or exchange beyond 30 days from the date of invoice. Packing and all transportation expenses are assumed by the customer. Excepting for the return or exchange of items covered by the standard terms of warranty, all other returned merchandise is subject to a 25% restocking charge, plus shipping and expenses provided the returned goods are unused, undamaged and in a resalable condition as determined by our inspection. The following information is required: invoice or packing list number, date of order, customer account number and purchase order number. Only Credit Memos are issued against material purchases for use within 6 months of Credit Memo date.

=====

## DAMAGED GOODS

=====

Inspect carton upon receipt for visible signs of damage. If carton is received conspicuously damaged, refuse acceptance and/or alert carrier to the condition. Do not contact us.

=====

## EXPORT ORDERS

=====

Purchase orders should clearly and separately indicate billing and shipping addresses, if different. Particular attention should be given to provide the city, postal code and country clearly in addition to other pertinent information that will assure receipt of ordered merchandise. Many orders are delayed in transit or Customs due to inadequate or incomplete shipping information. Normal shipping terms are: Ex-Factory.

Depending upon destination, export orders may be subjected to various additional charges for Customs Documentation, Certifications, Insurance, etc. Please request a Pro Forma Invoice prior to placement of orders to avoid any unnecessary delays. Our Export Department is experienced and will be pleased to offer any required assistance in assuring a prompt reply to accommodate export orders. Customs, documentation fees, taxes, etc. are assumed by the purchaser.

=====

## WARRANTY

=====

All products manufactured by Chemplex Industries, Inc. are guaranteed against defects in parts and workmanship for a period not to exceed **sixty (60)** days from date of invoice. Products and/or constituent components not manufactured by Chemplex Industries, Inc. are warranted only by the respective manufacturer(s) and in accordance with their terms and conditions. This warranty is limited to replacements or repairs of defective components as determined by our inspection and discretion. Certain products such as titanium carbide, tungsten carbide, agate, and zirconia are not guaranteed against chipping or breakage as indicated in their respective product descriptions.

=====

## REPRESENTATION

=====

Chemplex Industries, Inc. reserves the right to effect product additions, deletions, substitutions or changes in specifications and prices in accordance with good manufacturing practices, technology, material availability, safety and market trends without notification. Any information including actual products furnished by Chemplex Industries, Inc. is as representative as possible. Final independent testing and decision to determine product suitability and manner of product use is the sole responsibility of the customer. Chemplex Industries, Inc. further assumes no liability whatsoever for the accuracy or completeness of information contained on this catalog, or any written communications or correspondence, including product data sheets, web sites, advertising, exhibitions, etc., whether or not products are used in accordance with instructions, suggestions and contemplated use.

=====

## PRECAUTIONS

=====

All products supplied by Chemplex Industries, Inc. are available for purchase by all competent professionals in the scientific community. They are not intended for use in any FDA regulated application (e.g. foods, drugs, cosmetics) or for personal or household purposes. We expect our products to be judiciously handled and stored in our assumption that the purchaser is a qualified, safety-conscious and trained professional experienced with the techniques in which our products are insinuated for use. Our acceptance and filling of an order is based on this assumption and we must place the entire burden of safe handling, storage and application of our products on the customer. Material safety data sheets (MSDS), where applicable, are available only upon specific request and restricted to distribution to firms that have purchased the subject products.

**Chemplex**<sup>®</sup> INDUSTRIES, INC.

2820 SW 42<sup>nd</sup> Avenue  
Palm City, Fl. 34990-5573, USA

Continental USA Toll Free: (800) 4-CHEMPLEX

Phone: (772) 283-2700

Fax: (772) 283-2774

Email: [sales@chemplex.com](mailto:sales@chemplex.com)

Website: <http://www.chemplex.com>

**Internationally Serving X-Ray Spectroscopists  
Since 1971**

---

© 2012 Chemplex Industries, Inc. (All rights reserved)

® Sindie is a registered trademark of X-Ray Optical Systems, Inc.

® Mylar and Kapton are registered trademarks of E.I. DuPont de Nemours & Co., Inc.

® Chemplex, SpectroCertified, SpectroPellet, PelletCups, SpectroSet-Up, SpectroMix, SpectroMembrane, SpectroVial, SlipFit SpectroMill, SpectroPress, SpectroSulfur, SpectroCup, Ultra-Polyester, SpectroStandard, SpectroBlend, SpectroFilm, X-Ray Mix, GyalGrinder, Prolene, SpectroMicro, Etnom, TrimLess, Thermoplastic, Liquid-Binder and Chelasol are registered trademarks of Chemplex Industries, Inc.

® The Wizard is a registered trademark of Chemplex Industries, Inc.

™ PelletAid, FunnelShape, MultiAxial, PlastiCup, FusionFlux are trademarks of Chemplex Industries, Inc.